

Chartered Membership Examination

Friday 5 April 2013

Structural Engineering Design and Practice

09.30 – 13.00 and 13.30 – 17.00 (Discussion between individuals is not permitted during lunch period). A period of fifteen minutes is provided for reading the question paper, immediately before the commencement of the examination. Candidates are not permitted to write in answer sheets, or on drawing paper or to use a calculator during this time. Candidates must satisfy the Examiners in ONE question.

Important

The written answer to the question selected and any A3 drawings must bear the candidate's number and the question number at the bottom of the page. Only the answer sheets supplied by the Institution may be used. The candidate's name should not appear anywhere in the script.

Notes to Candidates

1. TO PASS THE EXAMINATION, CANDIDATES MUST SATISFY THE EXAMINERS IN BOTH PARTS OF THE QUESTION ATTEMPTED.
2. Examiners will only mark work written by hand during the examination.
3. A fair proportion of marks will be awarded for the demonstration of an understanding of fundamental engineering concepts, as distinct from calculation of member forces and sizes. NOTE: In the calculation part of all questions, establishing "form and size" is taken to mean compliance with all relevant design criteria, i.e. bending, shear, deflection, etc.
4. In all questions 50 marks are allocated to Section 1 and 50 marks to Section 2.
5. The Examiners are looking for sound structural designs. It should also be remembered that aesthetics, economy and function are important in any competent engineering scheme.
6. Any assumptions made and the design data and criteria adopted must be stated.
7. Portable computers or programmable calculators may be used but sufficient calculations must be submitted to substantiate the design, and these should be set out as in practice.
8. Good clear drawings and sketches are required; they should show all salient and structural features to suitable scales and should incorporate adequate details.
9. Candidates will not be allowed to include any previously prepared calculations, notes, sketches, diagrams, computer output or other similar material in their answer sheets or A3 drawings. Any previously prepared information submitted by candidates will be ignored by the Examiners.
10. Strictly no external electronic contact is allowed between a candidate and anyone outside the examination venue. Mobile phones must be switched off throughout the duration of the examination.
11. This paper is set in SI Units.

Now read 'Reminder' on page 3.

Chartered Membership Examination, a reminder from your Examiners

The work you are about to start has many features in common with other examinations which you have tackled successfully but it also has some which are unusual.

As in every examination you must follow carefully the NOTES FOR CANDIDATES set out for your guidance on the front cover of this paper; allocate the available time sensibly and set out your work in a logical and clear way.

The unusual requirement of the examination is that you demonstrate the validity of the training and experience that you have acquired in recent years. The Institution must be satisfied that you are able to bring all the various skills you are expected to possess to the effective solution of structural design problems – whether or not the problem is presented in terms that are within your actual experience.

Chartered Structural Engineers must have the ability to design and a facility to communicate their design intentions. Where you are required to list and discuss possible structural solutions you must show by brief, clear, logical and systematic presentation that you understand the general structural engineering principles involved.

In selecting and developing your design you should also remember the guidance given in the Institution's report, Aims of Structural Design, and in particular:

- (1) "the structure must be safe",
- (2) "a good design has certain typical features – simplicity, unity and necessity",
- (3) "the structure must fulfil its intended function".

If you have difficulty in deciding the correct interpretation of a question, pay particular attention to point 6. notes to candidates, on the front cover. The examiners will take into account your interpretation – and the design you base on this – if this is clearly stated at the beginning of your answer.

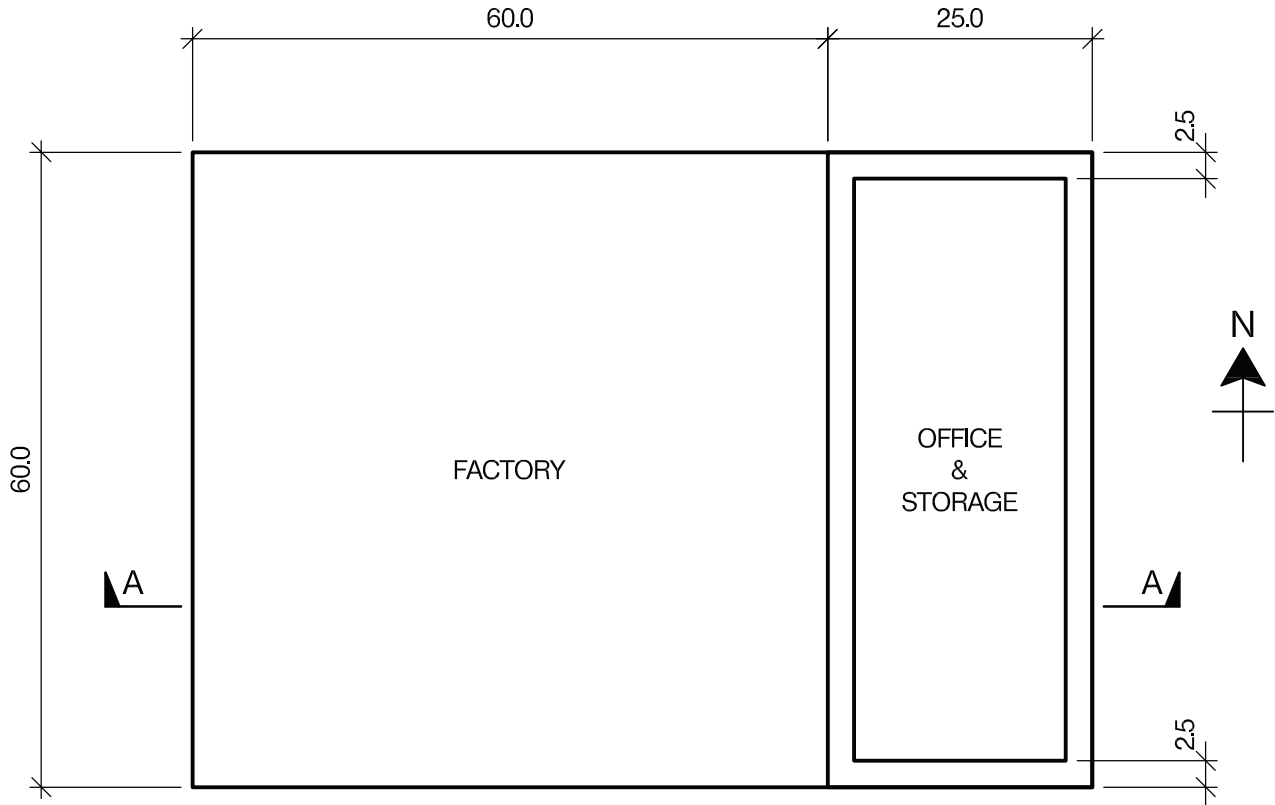

PLAN

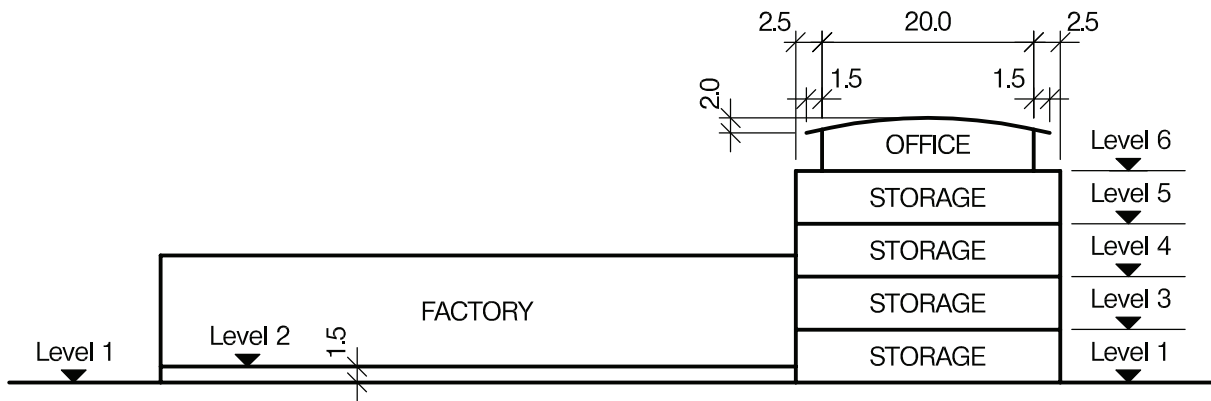

SECTION A - A

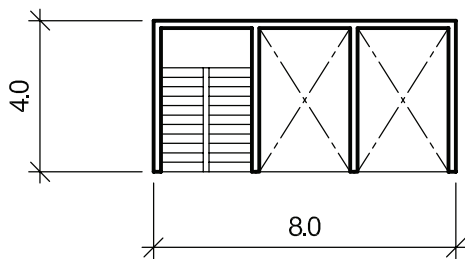

PLAN ON ACCESS CORE

NOTE: All dimensions are in metres

FIGURE Q1

Question 1. New factory, storage and office facility

Client's requirements

1. A new factory with storage and office facility to be built on a vacant site. See Figure Q1.
2. The floor to the factory, Level 2, is to be 1.5m above the external ground level, Level 1. The clear internal height required within the factory is 10.0m and the floor area is to be column free. The client requires six delivery doors to the factory each 5.0m long x 5.0m high equally spaced along the West elevation.
3. The storage floor areas are to have a clear internal floor to floor height of 4.0m and are to be column free. Two access cores each measuring 8.0m x 4.0m are required within the storage floor plan areas.
4. The office area is to be column free and is to have a clear internal height of 2.8m.
5. The perimeter of the factory and the storage facility is to be clad with composite metal panels with the columns at a minimum spacing of 6.0m. The walls to the office are to be clad with glass curtain walling with the columns at a minimum spacing of 6.0m.

Imposed loading

6. Roof	1.5kN/m ²
Factory floor	10.0kN/m ²
Storage floors	15.0kN/m ²
Office	3.5kN/m ²

Site conditions

7. The site is level and located on the outskirts of a large city. Basic wind speed is 40m/s based on a 3 second gust; the equivalent mean hourly wind speed is 20m/s.
8. Ground conditions:

Ground level – 2.0m	Made ground
2.0m – 5.0m	Sand and gravel N = 15
5.0m – 8.0m	Stiff to very stiff clay C = 250kN/m ²
Below 8.0m	Rock, allowable bearing pressure 1500kN/m ²

 Ground water was encountered at 4.0m below ground level.

Omit for consideration

9. Detail design of the stairs.

SECTION 1

(50 marks)

- a. Prepare a design appraisal with appropriate sketches indicating two distinct and viable solutions for the proposed structure. Indicate clearly the functional framing, load transfer and stability aspects of each scheme. Identify the solution you recommend, giving reasons for your choice. (40 marks)
- b. After the design has been completed the client advises you that he wishes to install two cranes running east to west supported on the perimeter columns and a central row of columns within the factory. Write a letter to the client explaining the effect this would have on the work and how his requirement may be accommodated. (10 marks)

SECTION 2

(50 marks)

For the solution recommended in Section 1(a)

- c. Prepare sufficient design calculations to establish the form and size of all the principal structural elements including the foundations. (20 marks)
- d. Prepare general arrangement plans, sections and elevations to show the dimensions, layout and disposition of the structural elements and critical details for estimating purposes. (20 marks)
- e. Prepare a detailed method statement for the safe construction of the building and an outline construction programme. (10 marks)

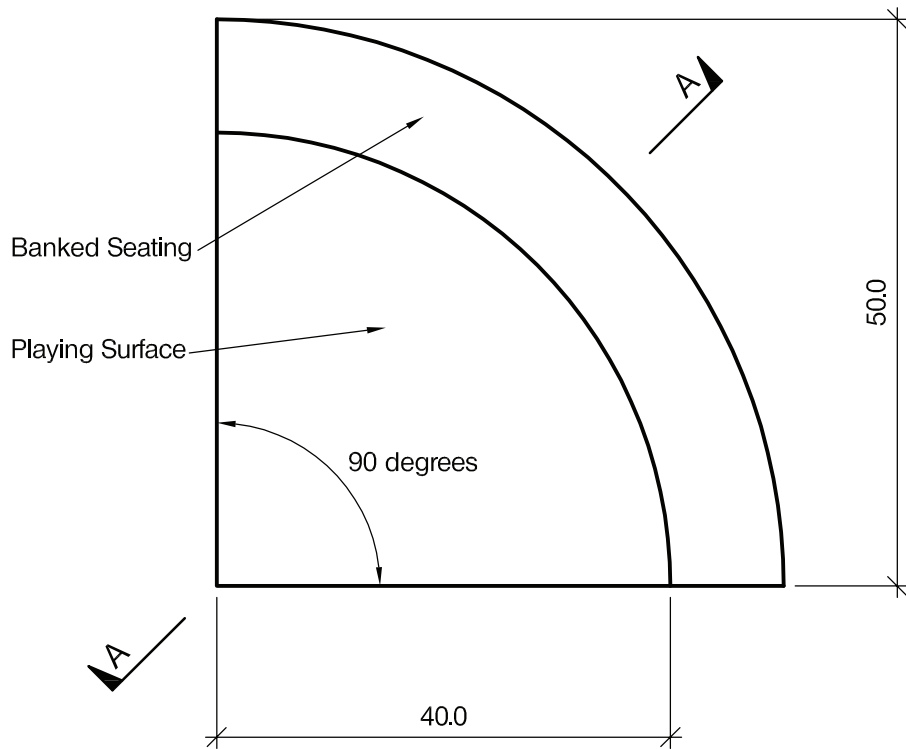

PLAN

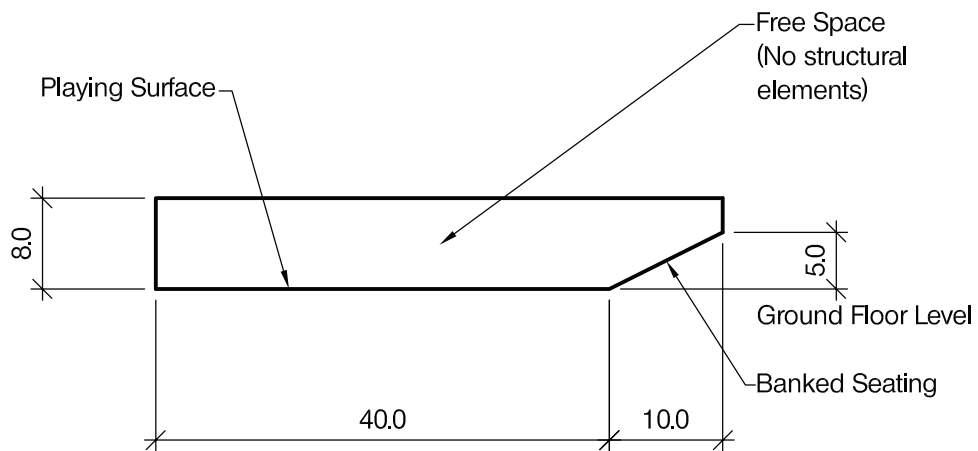

SECTION A - A

NOTE: All dimensions are in metres

FIGURE Q2

Question 2. Sports hall

Client's requirements

1. A new sports hall is required in the shape of a 90 degree circular sector. See Figure Q2.
2. The playing area is to be 40m radius and 8m high.No structural elements are allowed inside this space.
3. The sloping seating area is to be 10m wide and extend from ground level to 5m high.No columns or other structural members are permitted to obstruct the view of the playing area.
4. There are no restrictions to the structure outside the building envelope.
5. An existing reinforced concrete basement slab 0.2m thick has been discovered at 2m depth covering the whole site.
6. The playing area is to be covered in top soil so no ground floor slab is required. A minimum of 30 per cent of the roof area must be glazed to allow the growth of grass turf on the playing surface.

Imposed Loading

- | | |
|--------------------|----------------------|
| 7. Roof loading | 0.5kN/m ² |
| 8. Seating loading | 5.0kN/m ² |

Site conditions

9. The site is located in a coastal location. Basic wind speed is 46m/s based on a 3 second gust; the equivalent mean hourly wind speed is 23m/s.
10. Borehole for proposed sports hall

0m – 0.5m	Top soil
0.5m – 2.0m	Sand N=10
2.0m – 2.2m	Concrete slab
Below 2.2m	Dense Gravel N=30

Borehole for second sports hall	
0.0m – 4.0m	Loose clayey sand
4.0m – 7.0m	Sand N=10
Below 7.0m	Gravel N=20

No water was found in either borehole

Omit from consideration

11. Detailed design of seating including access stairs

SECTION 1

(50 marks)

- a. Prepare a design appraisal with appropriate sketches indicating two distinct and viable solutions for the proposed structure.Indicate clearly the functional framing, load transfer and stability aspects of each scheme.Identify the solution you recommend, giving reasons for your choice. (40 marks)
- b. After the completion of the Sports Hall the client decides to construct a second hall in another location where the ground conditions are given by a second borehole.Write a letter to your client advising him of the implications of this information. (10 marks)

SECTION 2

(50 marks)

For the solution recommended in Section 1(a):

- c. Prepare sufficient design calculations to establish the form and size of all the principal structural elements including the foundations. (20 marks)
- d. Prepare general arrangement plans, sections and elevations to show the dimensions, layout and disposition of the structural elements and critical details for estimating purposes. (20 marks)
- e. Prepare a detailed method statement for the safe construction of the building and an outline construction programme. (10 marks)

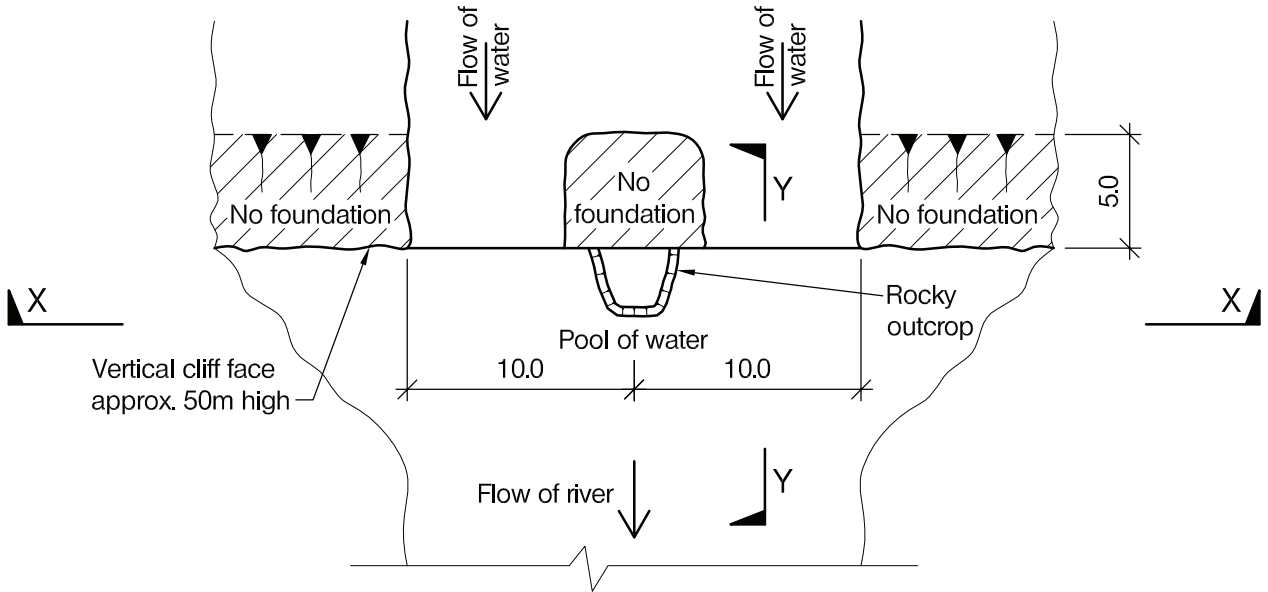

PLAN ON WATERFALL

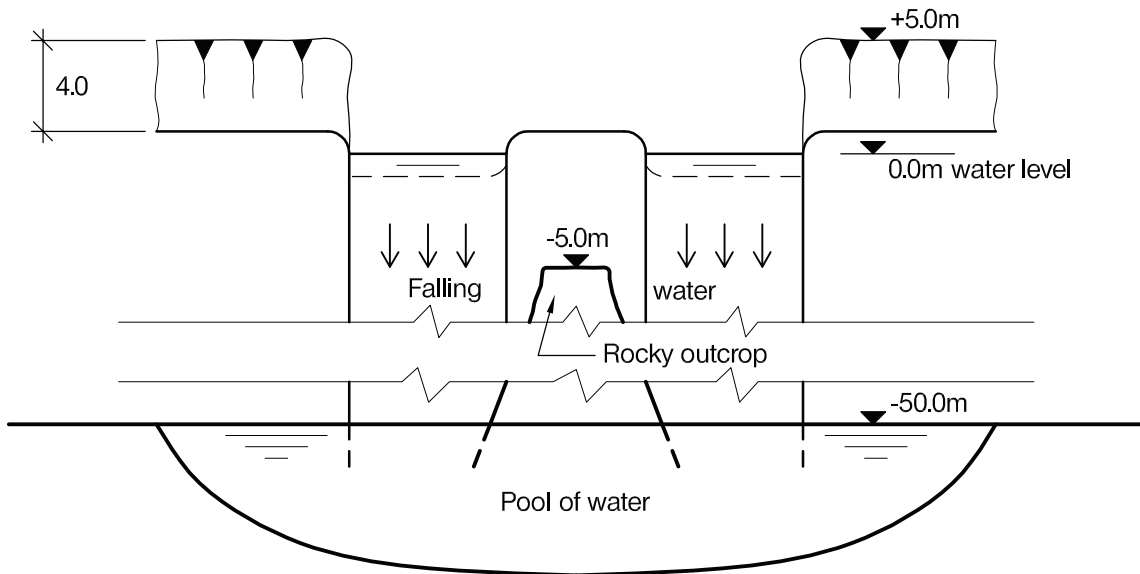

VIEW X - X

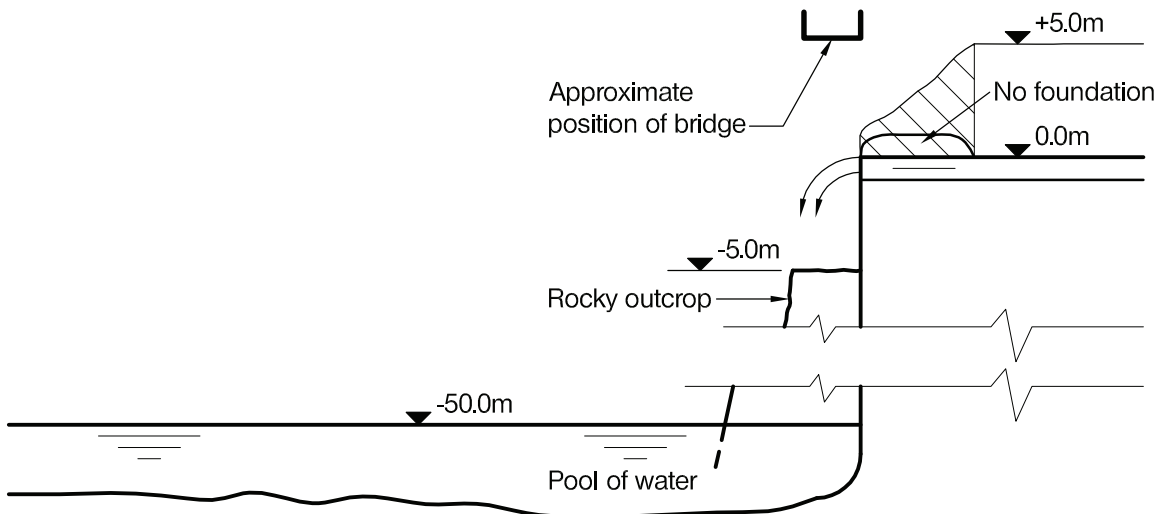

SECTION Y - Y

NOTE: All dimensions are in metres

FIGURE Q3

Question 3. Footbridge over a waterfall

Client's requirements

1. A 2.5m wide footbridge across a waterfall approximately 50.0m high. The bridge should be aesthetically pleasing and should provide dramatic views over the edge of the fall. See Figure Q3.
2. A rocky outcrop at mid-span with a plan area of approximately 3.0m x 3.0m may be used for vertical support. No other foundations are permitted within 5.0m of the edge of the fall.
3. For safety reasons, the river upstream of the bridge cannot be navigated and cannot be used for any construction activity.

Imposed loading

4. Uniformly distributed load 5.0kN/m²

Site conditions

5. The site is located in open countryside. Basic wind speed is 46m/s based on a 3 second gust; the equivalent mean hourly wind speed is 23m/s.
6. Ground conditions:

Granite	Allowable bearing capacity 2000kN/m ²
Rocky outcrop	Maximum unfactored vertical load 250kN

Omit from consideration

7. Longitudinal imposed loading.

SECTION 1

(50 marks)

- a. Prepare a design appraisal with appropriate sketches indicating two distinct and viable solutions for the proposed structure. Indicate clearly the functional framing, load transfer and stability aspects of each scheme. Identify the solution you recommend, giving reasons for your choice. (40 marks)
- b. After the design has been completed, investigation shows that the rocky outcrop is not able to be used for support. Write a letter to your client explaining the implications on your design. (10 marks)

SECTION 2

(50 marks)

For the solution recommended in Section 1(a):

- c. Prepare sufficient design calculations to establish the form and size of all the principal structural elements including the foundations. (20 marks)
- d. Prepare general arrangement plans, sections and elevations to show the dimensions, layout and disposition of the structural elements and critical details for estimating purposes. (20 marks)
- e. Prepare a detailed method statement for the safe construction of the works and an outline construction programme. (10 marks)

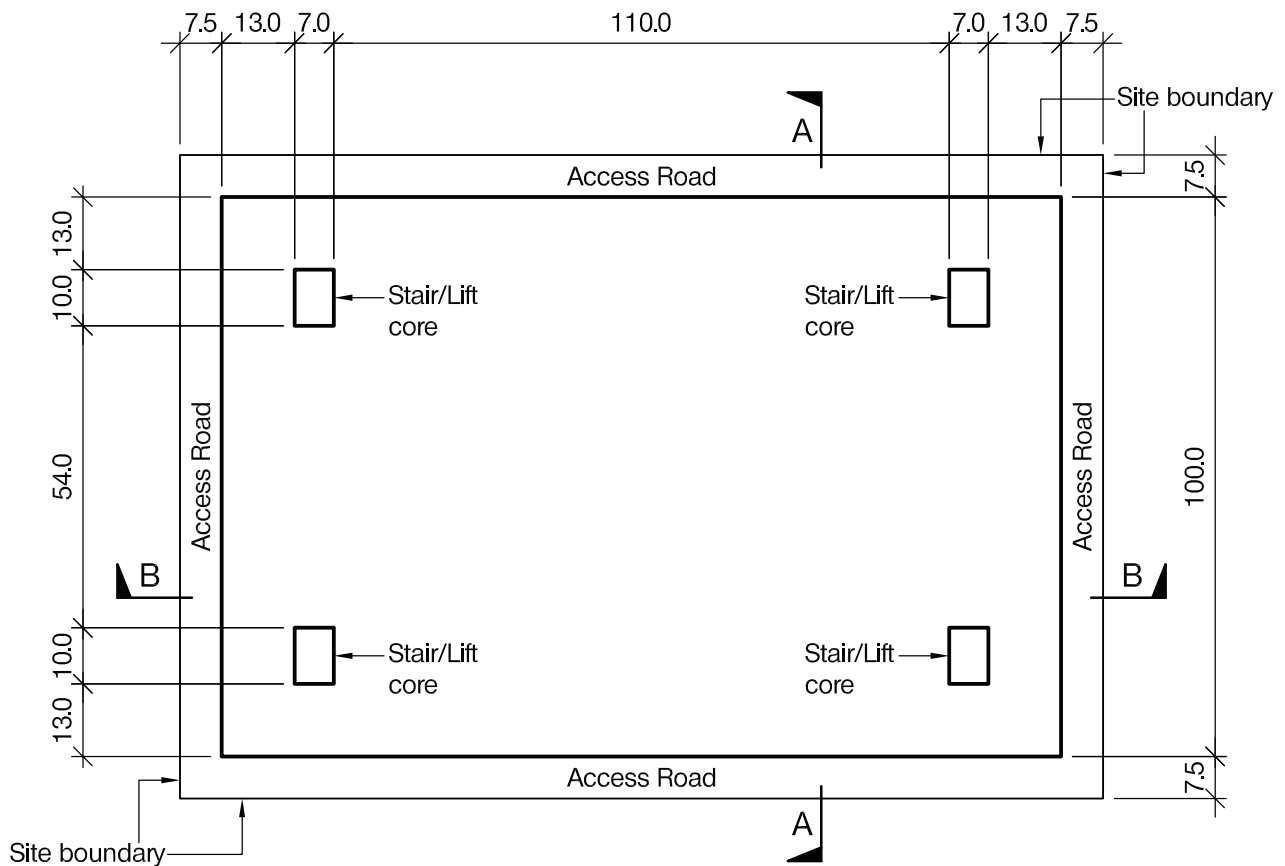

PLAN ON UNDERGROUND CAR PARK

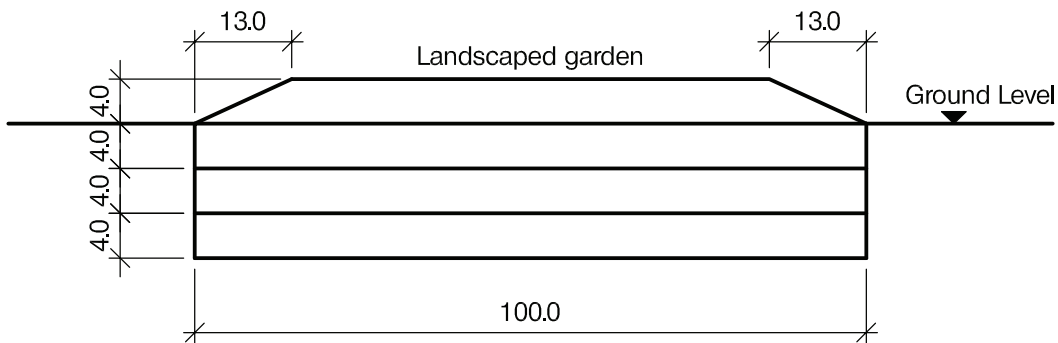

SECTION A - A

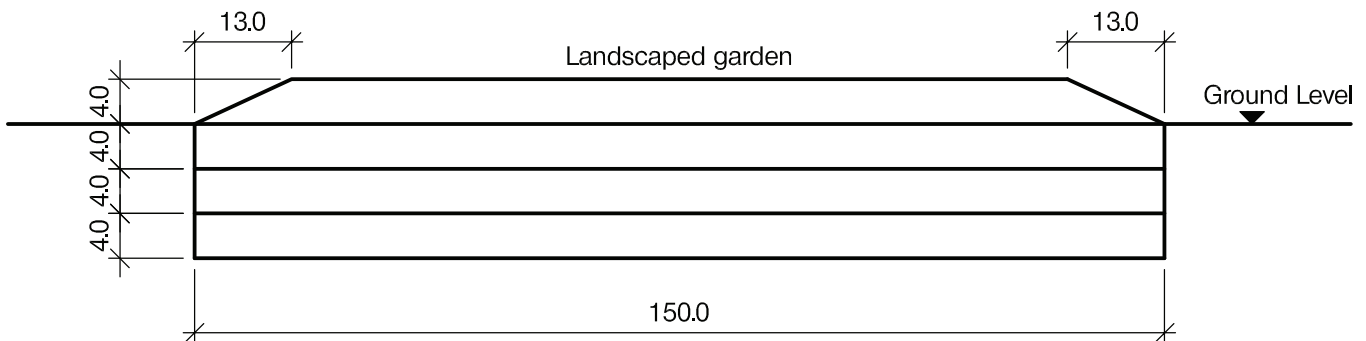

SECTION B - B

NOTE: All dimensions are in metres

FIGURE Q4

Question 4. Underground car park and garden

Client's requirements

1. An underground car park 150m long by 100m wide is to be built in a city centre. The car park is four storeys high with one level above ground level and the other three levels constructed underground. The roof of the car park will be used as a landscaped garden. See Figure Q4.
2. 4no. light wells are required at each level with a minimum total area of 320m² per level.
3. The storey height of each level is 4.0m.
4. The minimum fire resistance period for the structural elements is 4 hours.
5. The minimum size of each parking space is 2.5m wide by 4.8m long.
6. The minimum width of the access ramp is 7m.

Imposed loading

- | | |
|---------------------------|-----------------------|
| 7. Landscaped roof garden | 10.0kN/m ² |
| Car park floors | 2.5kN/m ² |

Site conditions

8. The site is on flat level ground in a city centre. Basic wind speed is 40m/s based on a 3 second gust, the equivalent mean wind speed is 20m/s.
9. Ground conditions:

Ground level - 5.0m	Loose sandy fill
5.0m - 12.0m	Silty sand, N values vary from 5 to 8
12.0m - 20.0m	Dense silty sand, N values vary from 35 to 80
Below 20.0m	Rock with compressive strength of 5000kN/m ²

Ground water was found at 2.0m below existing ground level.
For the design of basement use cohesion=0 and $\phi=35$ degrees

Omit from consideration

10. Detail design of lift and stairs.

SECTION 1

(50 marks)

- a. Prepare a design appraisal with appropriate sketches indicating two distinct and viable solutions for the proposed structure. Indicate clearly the functional framing, load transfer and stability aspects of each scheme. Identify the solution you recommend, giving reasons for your choice. (40 marks)
- b. After receiving your completed design, the client wants to add another level of basement (with a floor height of 4m) to cater for the future increase of cars. Write a letter to your client explaining the effect of this on your proposed design. (10 marks)

SECTION 2

(50 marks)

For the solution recommend in Section 1(a):

- c. Prepare sufficient design calculations to establish the form and size of all principal structural elements including the foundations. (20 marks)
- d. Prepare general arrangement plans, sections and elevations to show the dimension, layout and disposition of the structural elements and critical details for estimating purposes. (20 marks)
- e. Prepare a detailed method statement for the safe construction of the building and an outline construction programme. (10 marks)

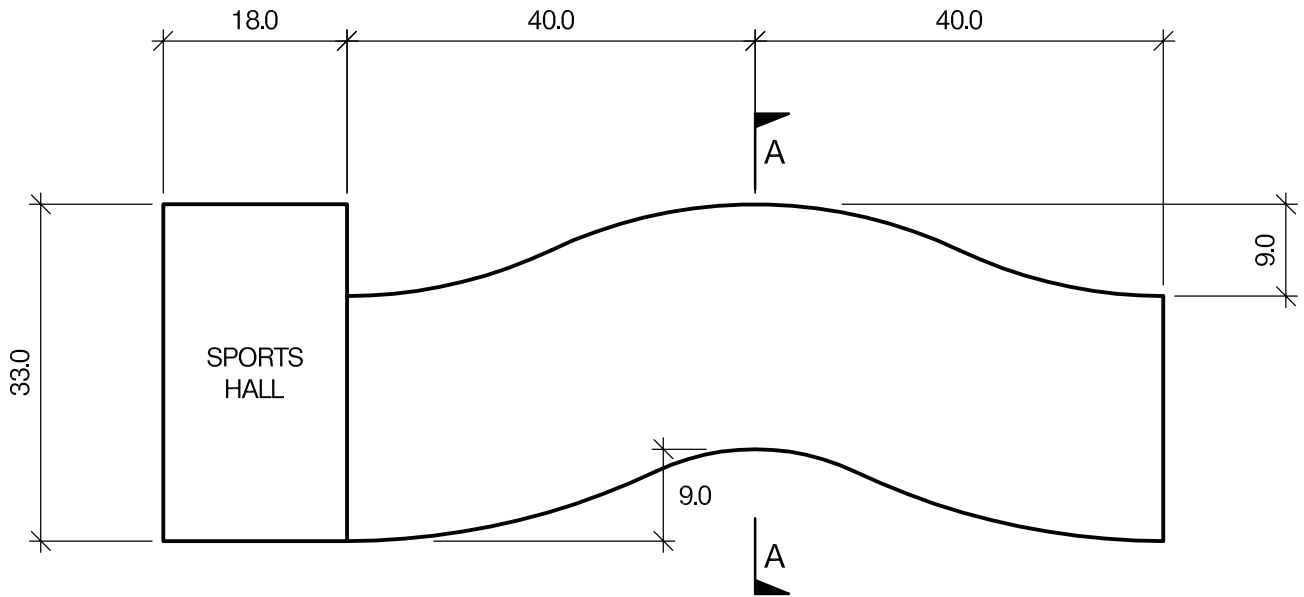

PLAN

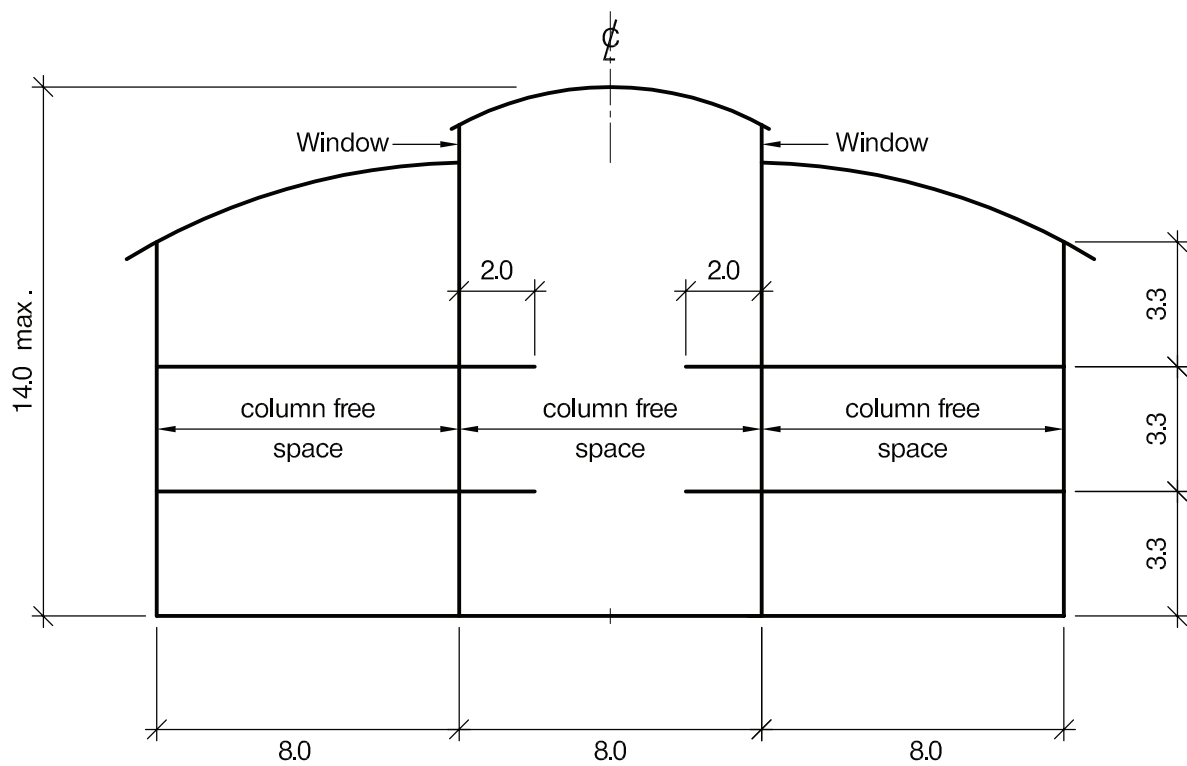

SECTION A - A

NOTE: All dimensions are in metres

FIGURE Q5

Question 5. School building

Client's requirements

1. A new three storey school building with a sports hall. The building is to be built on a sine curve to reflect the school's emphasis on mathematics. See Figure Q5.
2. The classrooms are to be located on each side of an internal "street" which has two windows between the main roof line and the street roof, see Section A-A. The windows to be 1m high.
3. Columns and/or walls are allowed on the external elevations and along the line of the internal walls of the classrooms. Clear height in classrooms shall be 2.7m and a 300mm clear service zone is required below the structural slab. The top storey shall have a minimum height to underside of roof structure of 3.0m.
4. No vertical bracing is allowed on the long elevations.
5. A 2.0m wide walkway is required on the upper storeys alongside the classrooms. These walkways shall be connected across the street with two bridges at each level. Staircases shall be provided between the storeys.
6. A single storey sports hall is required at one end of the building. This shall be 33m x 18m x 7.6m minimum clear height to underside of eaves. Columns shall not protrude from the walls.
7. One lift shall be provided for the building.
8. Minimum fire resistance period of 60 minutes is required for structural elements.

Imposed loading

- | | |
|--|--|
| 9. Floors | 3.0kN/m ² |
| Walkway and stairs | 4.0kN/m ² |
| Roof | 0.7kN/m ² |
| Horizontal loading on walkway balustrade | 1.5kN/m ² at 1.1m above walkway level |

Site conditions

10. Basic wind speed is 42m/s based on a 3 second gust: the equivalent mean hourly wind speed is 20.5m/s, the fundamental value of the basic wind velocity is 22m/s.
11. Ground conditions:

Ground level – 0.5m	Made ground
Below 0.5m	Silty clay $C_u=75\text{kN/m}^2$ increasing to $C_u=150\text{kN/m}^2$ at 10.0m
Water was encountered at 0.4m below ground level.	

Omit for consideration

12. Detail design of lift and stairs.

SECTION 1

(50 marks)

- a. Prepare a design appraisal with appropriate sketches indicating two distinct and viable solutions for the proposed structure. Indicate clearly the functional framing, load transfer and stability aspects of each scheme. Identify the solution you recommend, giving reasons for your choice. (40 marks)
- b. After completion of scheme design for the structure, the client decides to explore the possibility of increasing the sports hall to 34.8m x 21m x 9.1m high to allow the sports hall to be used in major competitions. Write a letter to the client, advising on the structural implications of this. (10 marks)

SECTION 2

(50 marks)

For the solution recommended in Section 1(a)

- c. Prepare sufficient design calculations to establish the form and size of all the principal structural elements including the foundations. (20 marks)
- d. Prepare general arrangement plans, sections and elevations to show the dimensions, layout and disposition of the structural elements and critical details for estimating purposes. (20 marks)
- e. Prepare a detailed method statement for the safe construction of the building and an outline construction programme. (10 marks)

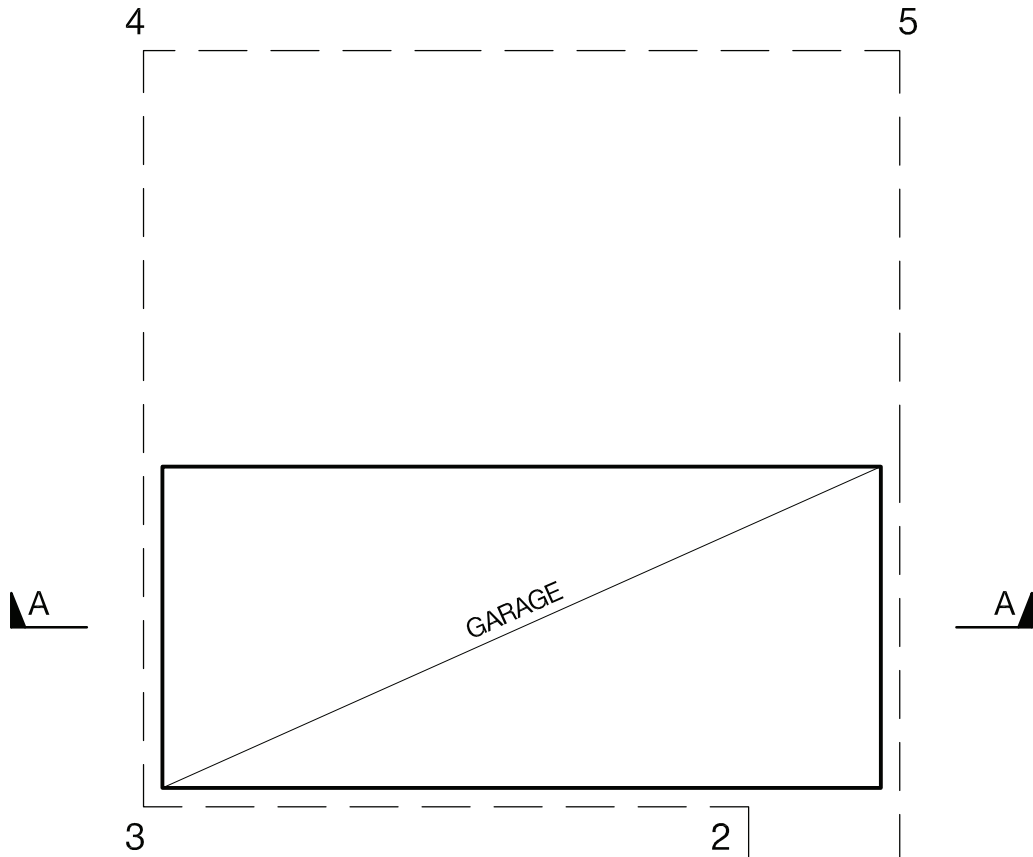

Site boundary →

BASEMENT PLAN

	EASTING	NORTHING
1	100	100
2	100	130
3	68	130
4	68	170
5	108	170
6	108	100



SITE CO-ORDINATES

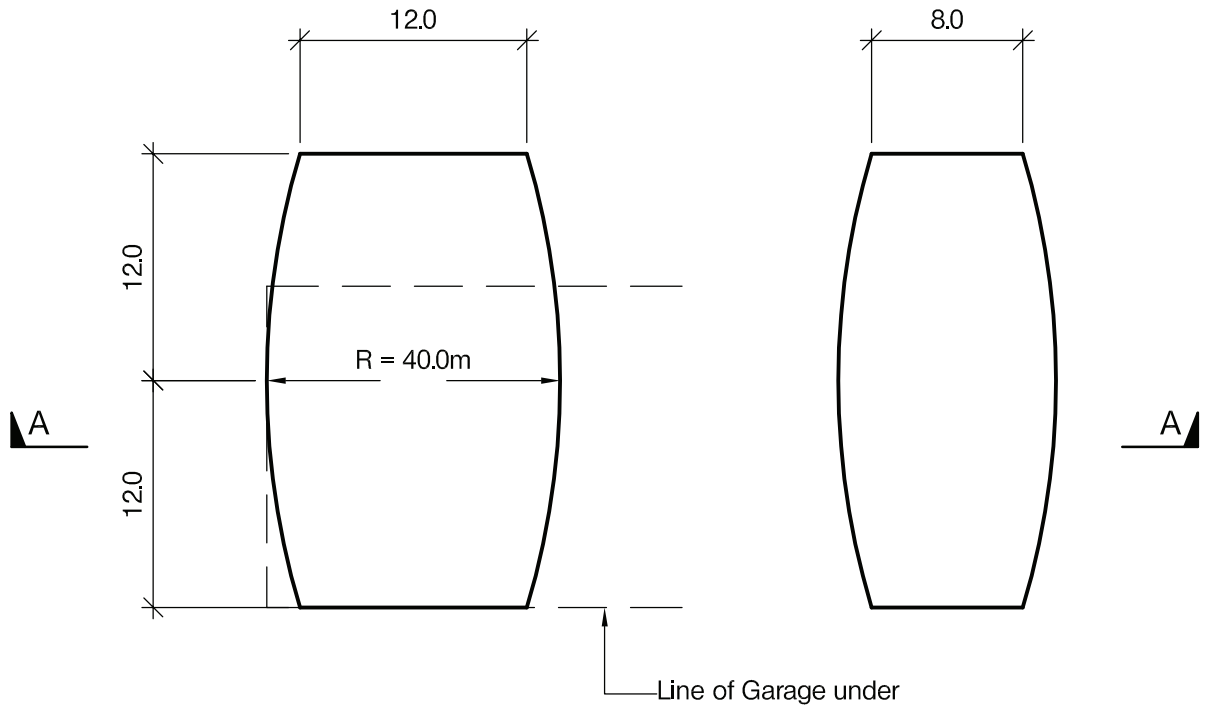

LEVEL 1 PLAN

LEVEL 2 PLAN

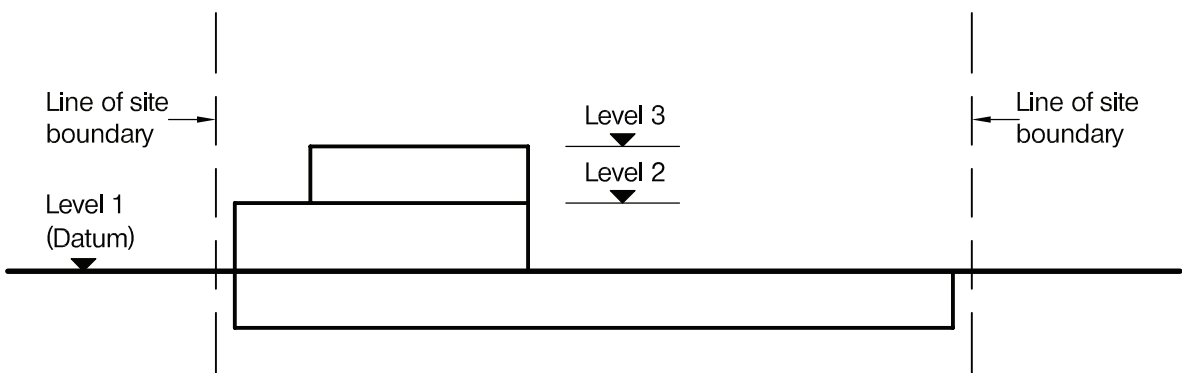

SECTION A - A

NOTE: All dimensions are in metres

Question 6. Mountain rescue centre

Client's requirements

1. A mountain rescue centre with a basement. The basement is to be used for garaging of emergency vehicles.
2. The coordinates of the site boundary and the building layouts at level 1 and level 2 are shown in Figure Q6.
3. A maximum of one row of internal columns is permitted in the basement and at level 1. No internal columns are permitted at level 2.
4. A minimum floor to ceiling height of 3.0m at level 1 and 2.4m at level 2 should be provided.
5. The basement must have parking space for a total of 18 vehicles and a 6m clear zone must be provided for reversing and manoeuvring of vehicles. Emergency vehicles require a parking space 3m wide x 8m long x 3m high.
6. Local regulations stipulate that no part of the building can be more than 9.0m above level 1, all buildings must have a slate covered pitched roof of not less than 10 degrees and buildings must be clad in natural stone.

Imposed loading

7. Floors	2.5kN/m ²
Partitions	1.0kN/m ²
Roof load, level 3	0.8kN/m ²
Basement roof load, level 1	2.5kN/m ²

Site conditions

8. The site is situated in open countryside. Basic wind speed is 49m/s based on a 3 second gust; the equivalent mean hourly wind speed is 23m/s.
9. Ground conditions:

Ground level to 0.5m	Granular fill
0.5m – 1.5m	Organic silty sand
1.5m to 3.0m	Sands and gravels N=15
Below 3.0m	Sand N=30

Ground water is located 2.8m below existing ground level.

Omit from consideration

10. Detail design of stairs and lift.

SECTION 1

(50 marks)

- a. Prepare a design appraisal with appropriate sketches indicating two distinct and viable solutions for the proposed structure. Indicate clearly the functional framing, load transfer and stability aspects of each scheme. Identify the solution you recommend, giving reasons for your choice. (40 marks)
- b. After completion of your design the client asks for all columns in the basement to be omitted and a 16m diameter helicopter landing pad with an imposed load of 5.0kN/m² to be provided next to the building above the basement. Write a letter to your client explaining how this might be achieved advising the structural implications. (10 marks)

SECTION 2

(50 marks)

For the solution recommended in Section 1(a)

- c. Prepare sufficient design calculations to establish the form and size of all the principal structural elements including the foundations. (20 marks)
- d. Prepare general arrangement plans, sections and elevations to show the dimensions, layout and disposition of the structural elements and critical details for estimating purposes. (20 marks)
- e. Prepare a detailed method statement for the safe construction of the building and an outline construction programme. (10 marks)

PRE-ASSEMBLED UNIT FOR TERMINAL EXPANSION FACILITY

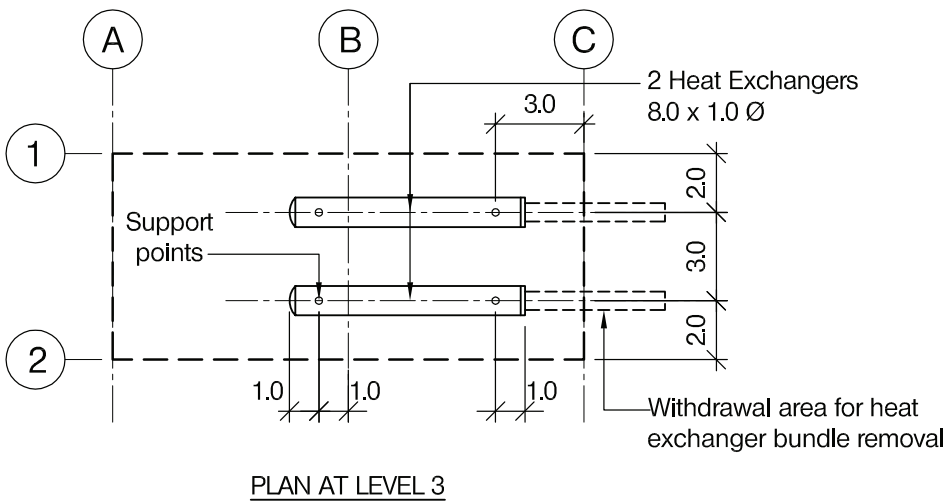
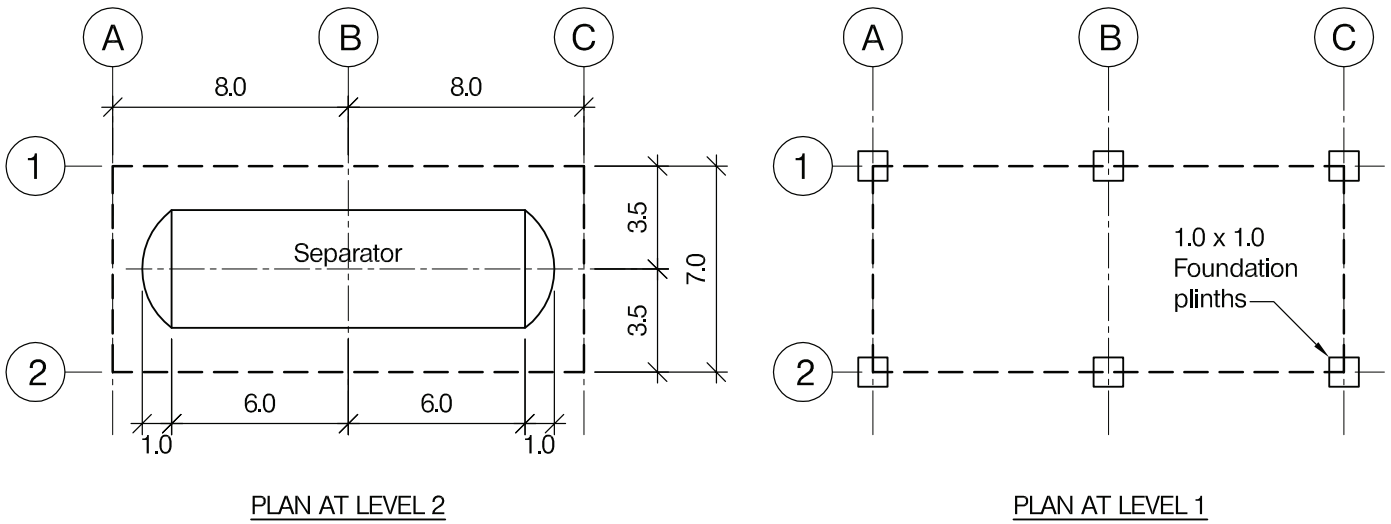
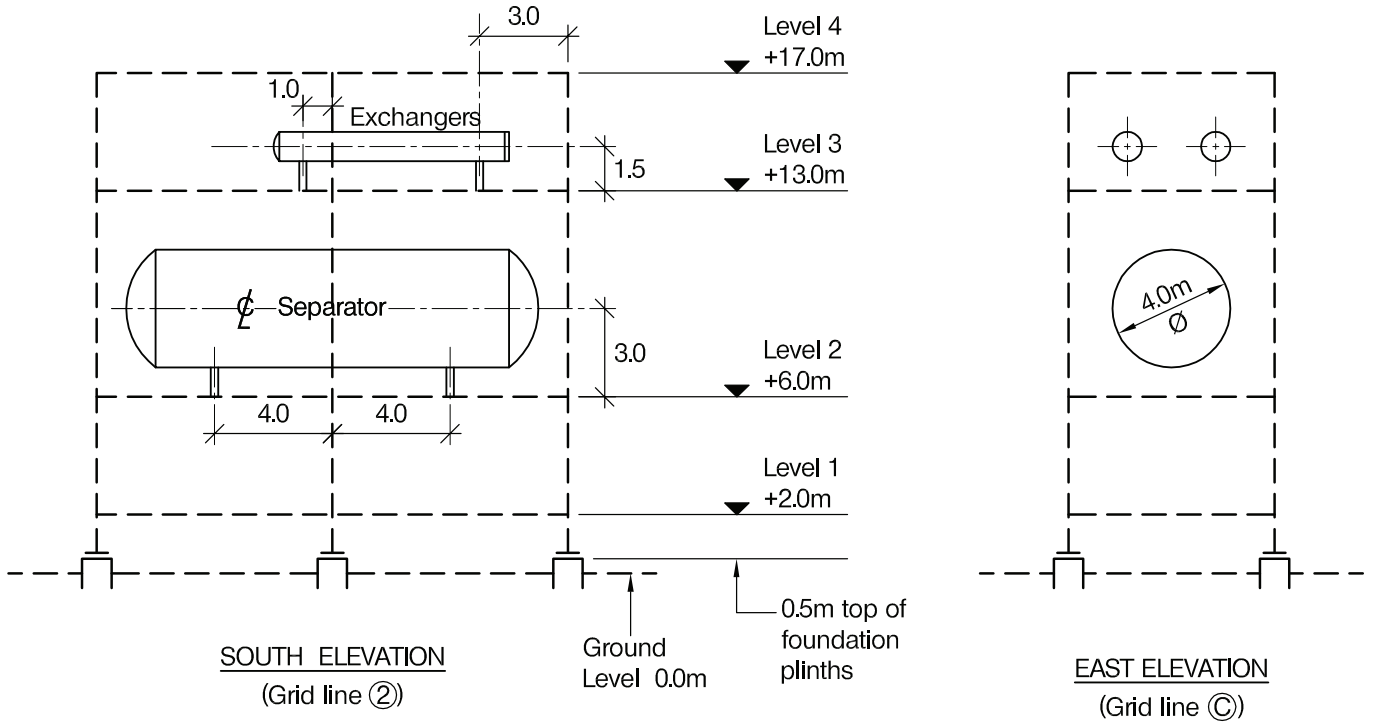

NOTE: All dimensions are in metres

FIGURE Q7

Question 7. Pre-assembled unit for terminal expansion project

Client's requirements

1. A new Pre-Assembled Unit (PAU) containing one production separator and two heat exchangers is required to be installed onto an existing foundation at an onshore terminal, as part of an expansion project. See Figure Q7.
2. The PAU deck area is 16.0m by 7.0m, and consists of four levels, as shown in Figure Q7.
3. All PAU deck levels are to be open-grated, not plated, to allow free ventilation. Note open-grating does not offer lateral restraint to floor beams.
4. The East elevation at level 3 must permit a clear withdrawal area for heat exchanger bundle removals.
5. Internal framing must be avoided to provide open space for facilities and access.
6. The PAU is to be constructed and outfitted in a North European site and transported across the North Sea by small barge to an onshore terminal, and lifted onto the foundation plinths by a large capacity site-crane.

Imposed loading

7. Production separator dry weight 75 tonnes
 Production separator operating weight 150 tonnes
 Heat exchanger dry weight 15 tonnes each
 Heat exchanger operating weight 20 tonnes each
 Levels 1 and 4 deck levels and unoccupied areas of level 2 and 2 decks, design load 10.0kN/m².

Site conditions

8. The site is level and is located in a coastal area. Basic wind speed is 55m/sec based on a 3 second gust. The equivalent mean hourly wind speed is 28m/sec.

Omit from consideration

9. Design of access staircases.
10. Design of foundations.

SECTION 1

(50 marks)

- a. Prepare a design appraisal with appropriate sketches indicating two distinct and viable solutions for the proposed structure. Indicate clearly the functional framing, load transfer and stability aspects of each scheme for all temporary and permanent design phases to be considered, ie, loadout, transport, lift and in-place operation. Identify the scheme you recommend, giving reasons for your choice. (40 marks)
- b. After completion of your design, a safety review is carried out, that recommends the PAU be designed to resist an explosion drag pressure of 0.3 Bar (30.0kN/m²) in both directions. Write a letter to the client explaining the effects this would have on your chosen solution. (10 marks).

SECTION 2

(50 marks)

For the solution recommended in Section 1(a):

- c. Prepare sufficient design calculations to establish the form and size of all structural elements for both the temporary and permanent conditions. (20 marks)
- d. Prepare general arrangement plans, sections and elevations to show the dimensions, layout and disposition of the structural elements and joints. Prepare clearly annotated sketches to illustrate details of: lift points on PAU, support points onto foundation plinths and typical beam to column connection at level 2. (20 marks)
- e. With the aid of fully annotated sketches describe the installation procedure for the new PAU, from leaving the Northern Europe construction yard to final installation on terminal foundations. (10 marks)

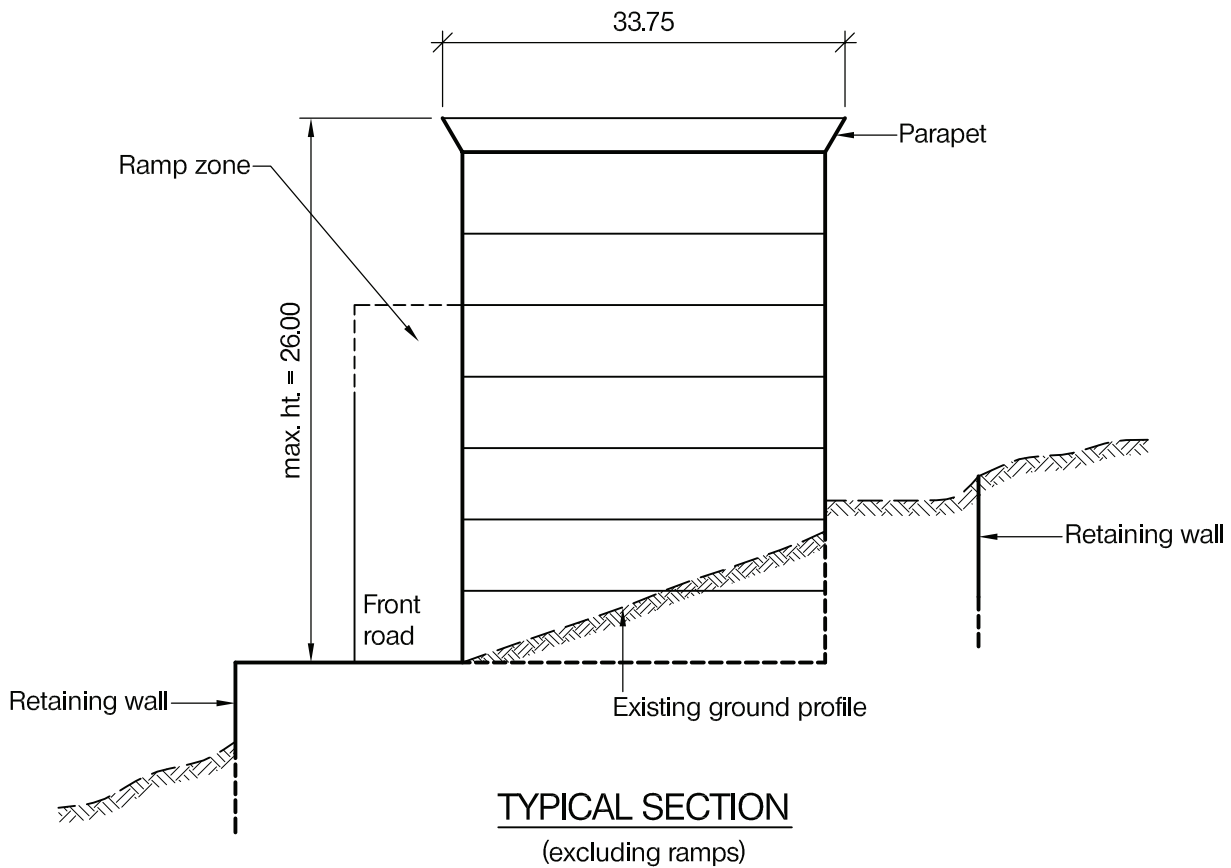
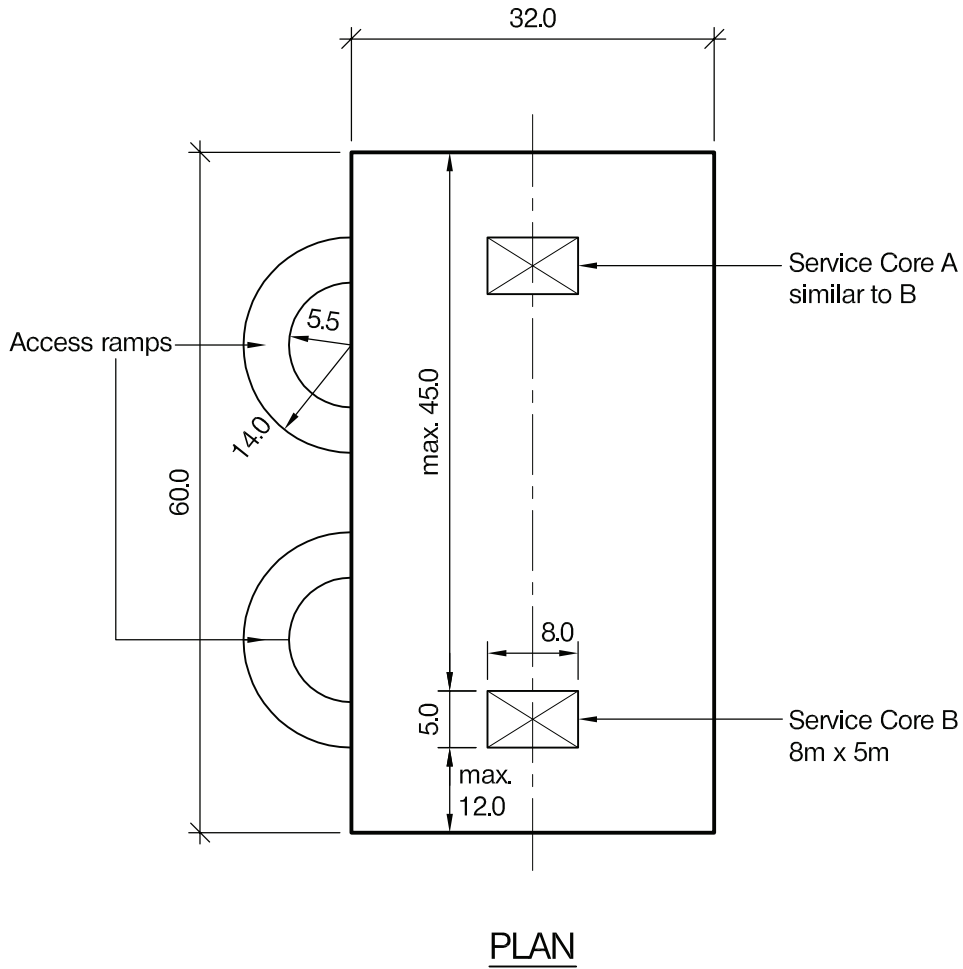

NOTE: All dimensions are in metres

FIGURE Q8-1

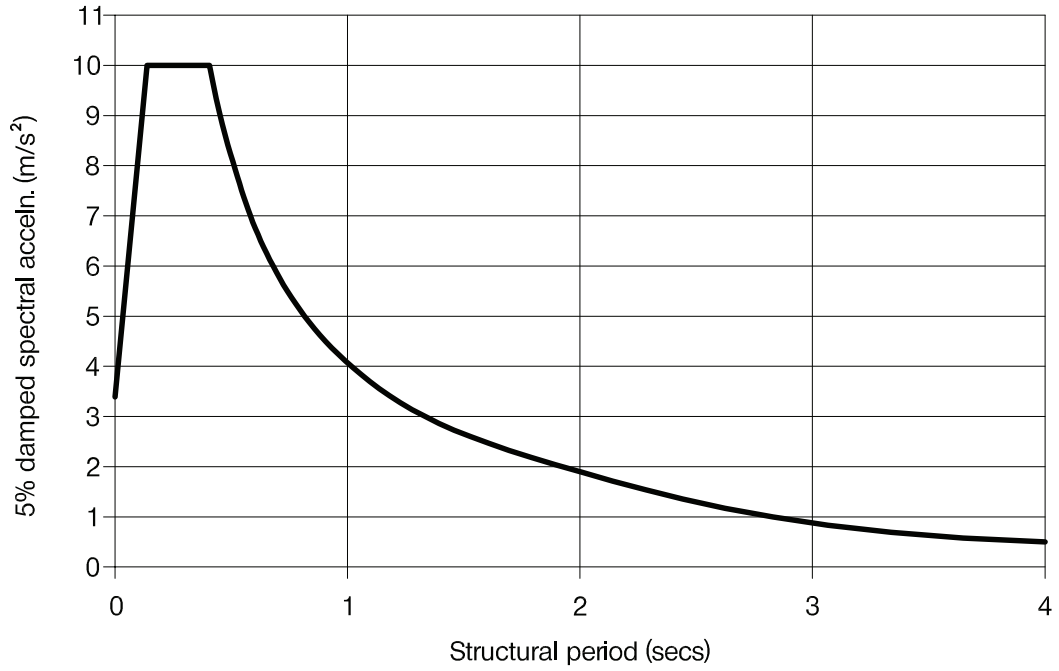

FIGURE Q8-2 : 475 year return period motions for rock outcrop at site

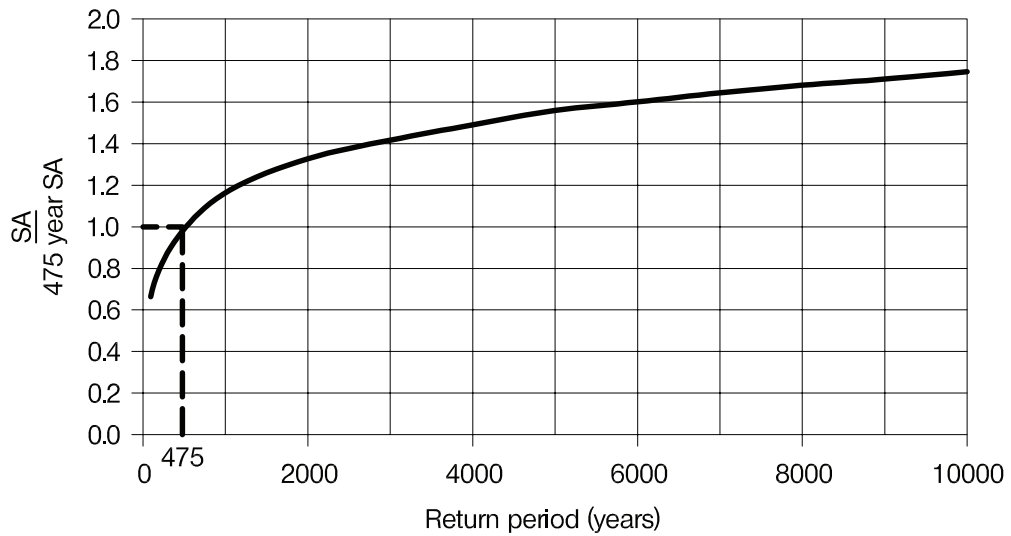

FIGURE Q8-3 : Variation of spectral acceleration SA with return period

Question 8. A multi-storey car park with top floor restaurant

Client's requirements

1. The client requires a six-storey car park with a restaurant on the top floor to be constructed in a prestigious shopping centre close to the centre of a major city in an area of high seismicity.
2. The site is sloping between the main roads. The car park is a flat deck car park with semi - circular external vehicular access ramps from the front road. See Figure Q8-1.
3. Only one line of internal columns is permitted in the car parking floors. Clear space between columns is to be 7.2m.
4. The clear floor heights to be 3.0m for restaurant and 2.3m for car park zones. The total height of the building should not exceed 26m, including a 1.5m high outward inclined parapet (architectural feature).
5. The roof is flat in lightweight construction. Externally the building is to be clad with full height lightweight architectural panels and fully glazed at the top restaurant floor.
6. A minimum fire resistance period of 2 hours is required for structural elements.

Imposed loading

7. Car park areas	2.5kN/m ²
Restaurant and service cores	5.0kN/m ²
Roof	1.5kN/m ²

Site conditions

8. The site is located in an inner city area. The basic wind speed is 46m/s on a 3-second gust; the equivalent mean hourly wind speed is 23m/s.
9. Ground conditions (depths measured with respect to natural soil level at each location):

0.0m - 1.5m	Made Ground
Below 1.5m	Very dense sand and gravel (N=50)

 No ground water was encountered.
10. Figure Q8-2 shows the design 5% damped seismic response spectrum for the region. It applies to level ground for a 475 year return period, assuming the ground surface is rock with a shear wave velocity of not less than 800m/s.

Omit from consideration

11. Detailed design of staircase/lift, facade cladding, retaining walls, and ramps.

SECTION 1

(50 marks)

- a. Prepare a design appraisal with appropriate sketches indicating two distinct and viable solutions for the proposed structure. Indicate clearly the functional framing, load transfer and stability aspects of each scheme. Identify the solution you recommend, giving reasons for your choice. (40 marks)
- b. After completion of scheme design for the structure, the client inquires whether it will be possible to increase the clear floor height in the ground floor to 4.0m to accommodate a shop floor assuming that the overall building height can be exceeded by the same amount. Write a letter for the client, advising on the structural implications of this change, with a description of ways of accommodating it. (10 marks)

SECTION 2

(50 marks)

- c. Prepare sufficient design calculations to establish the form and size of all the principal structural elements including the foundations. (20marks)
- d. Prepare general arrangement plans, sections and elevations to show the dimensions, layout and disposition of the structural elements and critical details for estimating purposes. (20 marks)
- e. Prepare a detailed method statement for the safe construction of the building and an outline construction programme. (10 marks)

The Institution of Structural Engineers
International HQ
11 Upper Belgrave Street
London SW1X 8BH
United Kingdom
tel: +44 (0)20 7235 4535
fax: +44 (0)20 7235 4294
mail@istructe.org
www.istructe.org
Registered Charity