

## Chartered Membership Examination

Thursday, 3 January 2019

### Structural Engineering Design and Practice

09.30 – 13.00 and 13.30 – 17.00 (Discussion between individuals is not permitted during lunch period). A period of fifteen minutes is provided for reading the question paper immediately before the commencement of the examination. Candidates are not permitted to write in answer sheets, or on drawing paper or to use a calculator during this time. Candidates must satisfy the Examiners in ONE question.

### Important

The written answer to the question selected and any A3 drawings must bear the candidate's number and the question number at the bottom of the page. Only the answer sheets supplied by the Institution may be used. The candidate's name should not appear anywhere in the script.

### Notes to Candidates

1. TO PASS THE EXAMINATION, CANDIDATES MUST SATISFY THE EXAMINERS IN BOTH PARTS OF THE QUESTION ATTEMPTED.
2. Candidates should note that Figures are produced to illustrate the question and are not necessarily drawn to scale. Figured dimensions should be followed.
3. A fair proportion of marks will be awarded for the demonstration of an understanding of fundamental engineering concepts, as distinct from calculation of member forces and sizes. NOTE: In the calculation part of all questions, establishing "form and size" is taken to mean compliance with all relevant design criteria, i.e. bending, shear, deflection, etc.
4. In all questions 50 marks are allocated to Section 1 and 50 marks to Section 2.

5. The Examiners are looking for sound structural designs. It should also be remembered that aesthetics, economy and function are important in any competent engineering scheme.
6. Any assumptions made and the design data and criteria adopted must be stated.
7. Clear drawings and sketches are required. They do not have to be to a defined scale, but should be in proportion.
8. Candidates will not be allowed to include any previously prepared calculations, notes, sketches, diagrams, computer output or other similar material in their answer sheets or A3 drawings. Any previously prepared information submitted by candidates will be ignored by the examiners.
9. Candidates may not bring into the examination room any electronic devices capable of wireless communication, optical photography or scanning.

The following devices are not permitted: Mobile phones, Laptops, notebooks or portable computers and similar devices, iPads, tablets and similar devices, E-readers (e.g. Kindle) and similar devices, cameras, optical scanners and similar devices.

Any candidates arriving at the examination room with such devices will be asked to switch them off and place them in a sealed bag kept by the Invigilator for the duration of the exam, which includes the lunch period.

10. This paper is set in SI Units.

**Now read 'Reminder' on page 3.**



2 Chartered-Membership Examination



# Chartered Membership Examination, a reminder from your Examiners

The work you are about to start has many features in common with other examinations which you have tackled successfully but it also has some which are unusual.

As in every examination you must follow carefully the NOTES FOR CANDIDATES set out for your guidance on the front cover of this paper; allocate the available time sensibly and set out your work in a logical and clear way.

The unusual requirement of the examination is that you demonstrate the validity of the training and experience that you have acquired in recent years.

The Institution must be satisfied that you are able to bring all the various skills you are expected to possess to the effective solution of structural design problems – whether or not the problem is presented in terms that are within your actual experience.

Chartered Structural Engineers must have the ability to design and a facility to communicate their design intentions. Where you are required to list and discuss possible structural solutions you must show by brief, clear, logical and systematic presentation that you understand the general structural engineering principles involved.

In selecting and developing your design you should also remember the guidance given in the Institution's report, Structural design - achieving excellence, and in particular:

- (1) "the structure must be safe",
- (2) "a good design has certain typical features – simplicity, unity and necessity",
- (3) "the structure must fulfil its intended function".

If you have difficulty in deciding the correct interpretation of a question, pay particular attention to point 6. notes to candidates, on the front cover. The examiners will take into account your interpretation – and the design you base on this – if this is clearly stated at the beginning of your answer.

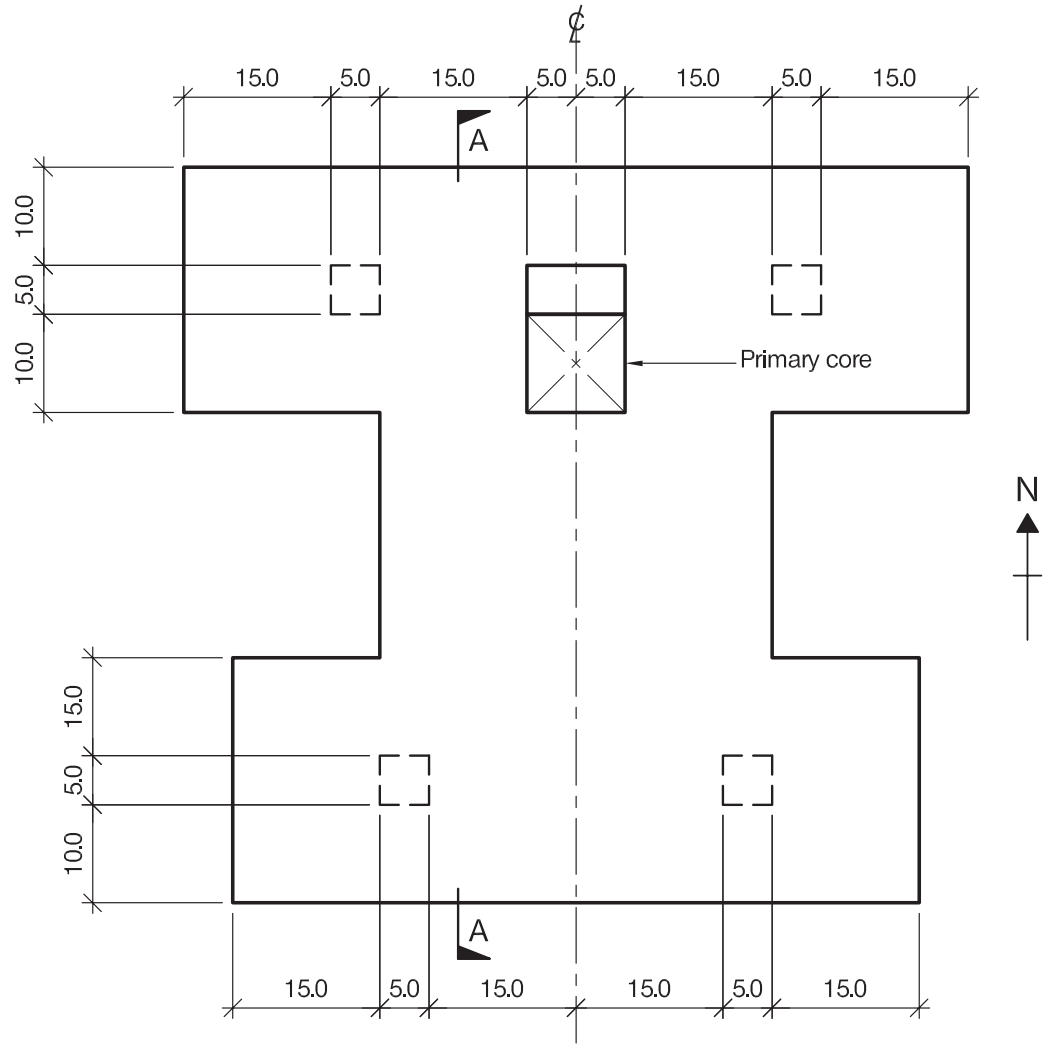

PLAN AT LEVEL 6 (with secondary cores)

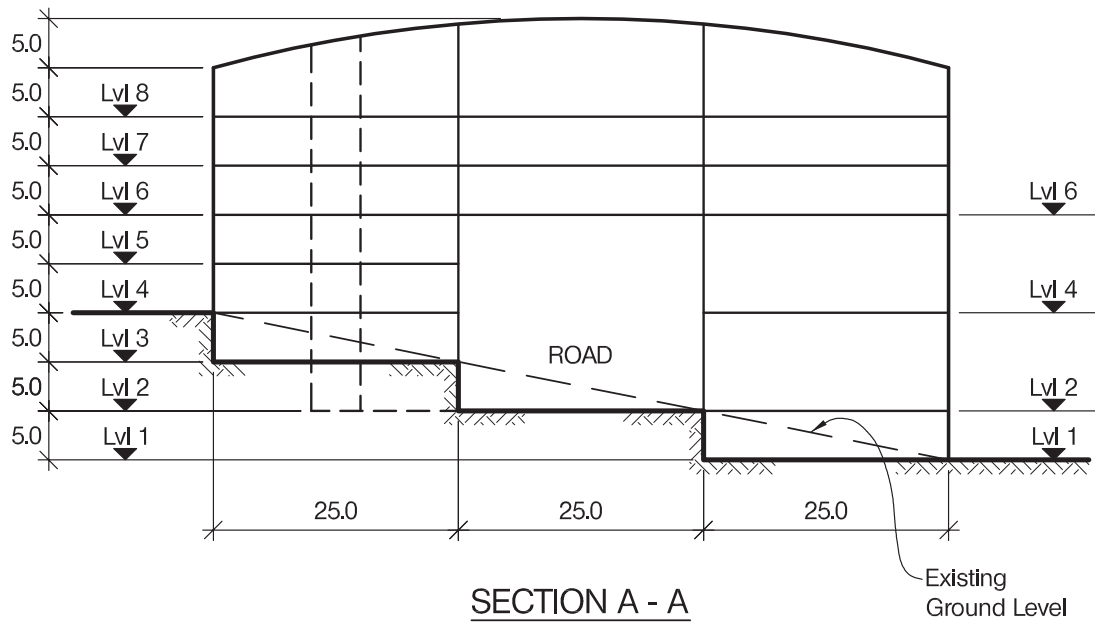

SECTION A - A

NOTE: All dimensions are in metres

FIGURE Q1

# Question 1. New Research and Manufacturing Facility

## Client's requirements

1. A new research and manufacturing facility consisting of two manufacturing floors at Levels 2 & 4 on the South Wing with ancillary research accommodation on all remaining levels in the North and South Wings. See Figure Q1.
2. The building is to be constructed on a sloping site. There is an existing access road running West/East through the centre of the building which cannot be obstructed.
3. The manufacturing floors are to have a clear internal floor-to-ceiling height of 7.0m. One row of internal columns is permitted within the floor area.
4. The research areas are to have a clear internal floor-to-ceiling height of 3.5m. One row of internal columns is permitted within the floor area. A clear 200mm service zone is required between the ceiling and the underside of the structure.
5. The elevations are to be fully glazed and external columns are to be at a minimum spacing of 5.0m.
6. In addition to the primary core area indicated on Figure Q1 two secondary cores as outlined on Figure Q1 are required in both the North and South Wings.

## Imposed Loading

7. Roof	0.60kN/m <sup>2</sup>
Research	3.5kN/m <sup>2</sup>
Manufacturing	5.0kN/m <sup>2</sup>

## Site Conditions

8. The site is located on the outskirts of a large city. Basic wind speed is 40m/s based on a 3-second gust; the equivalent mean hourly wind speed is 20m/s.
9. Ground conditions vary parallel with the ground surface:
 

Ground level – 1.0m	top soil / fill
1.0m –8.0m	dense silty sand, N = 20
Below 8.0m	rock, allowable bearing pressure 3,000kN/m <sup>2</sup>

 No ground water was encountered.

## Omit from Consideration

10. Detailed design of the lift and stairs.

## SECTION 1

**(50 marks)**

- a. Prepare a design appraisal with appropriate sketches indicating two distinct and viable solutions for the proposed structure including the foundations. Indicate clearly the functional framing, load transfer, serviceability, and stability aspects of each scheme. Review and critically appraise the schemes, and identify the solution you recommend, giving reasons for your choice. (40 marks)
- b. After the design has been completed the Client advises you that they wish to add an additional floor for research use below the North Wing down to Road Level 2. Write a letter to the Client explaining the implications on your design. (10 marks)

## SECTION 2

**(50 marks)**

For the solution recommended in Section 1(a):

- c. Prepare sufficient design calculations to establish the form and size of all the principal structural elements including the foundations. (20 marks)
- d. Prepare general arrangement drawings, which may include plans, sections and elevations, to show the dimensions, layout and disposition of the structural elements and critical details for estimating purposes. (20 marks)
- e. Prepare a detailed method statement for the safe construction of the facility and an outline construction programme to include consideration of any temporary works that may be required. (10 marks)



## Question 2. Mixed use building

### Client's requirements

1. A new six-storey mixed-use building is to be constructed in a city centre on a plot adjacent to an existing main road. See Figure Q2.
2. The finished floor-to-floor heights for the shopping and office floors are 5.0m and 4.0m respectively. Minimum clear floor-to-ceiling heights of 3.65m and 2.80m are required in shopping and office floors respectively, with a minimum 400mm ceiling void for services. The clear floor-to-ceiling height in the concourse area must be at least 6.5m with a minimum 500mm ceiling void for services.
3. The concourse and canteen are in the middle part of the building on Level 1 and Level 5 and have twice the clear floor heights of shop and office floors respectively. The roof above the canteen area must be glazed to allow the entry of natural light.
4. Two lift/staircase cores are to be provided over the full height of the building as shown in Figure Q2.
5. The front elevation of the building will be fully glazed. 65% of the side and rear elevations will be glazed and the remainder will be clad with stone panels. No bracing is allowed in the front elevation.
6. No internal columns are permitted in the concourse zone of the building. Elsewhere, internal and external columns must be placed not less than 7.00m apart.

### Imposed loading

- |                          |                       |
|--------------------------|-----------------------|
| 7. Roof                  | 1.5 kN/m <sup>2</sup> |
| Office/Canteen           | 5.0 kN/m <sup>2</sup> |
| Shops/Concourse/Entrance | 7.5 kN/m <sup>2</sup> |

### Site conditions

8. The site is located in the centre of a large city. The basic wind speed is 40m/s based on a 3-second gust; the equivalent mean hourly wind speed is 20m/s.

9. Ground conditions:

Borehole 1:

Existing Ground level – 1.0m	Top soil and fill
1.0m – 6.0m	Dense silty sand $\Phi = 33$ degrees
6.0m – 9.5m	Dense sand N=30
Below 9.5m	Rock, characteristic compressive strength = 4,500kN/m <sup>2</sup>

Borehole 2:

Existing Ground level – 1.0m	Top soil and fill
1.0m – 4.5m	Sand and gravel N=15
Below 4.5m	Rock, characteristic compressive strength = 4,500kN/m <sup>2</sup>

Ground water was encountered at 6.3m below ground level in BH1 and at 1.3m below ground level in BH2.

### Omit from consideration

10. Detailed design for staircases and lifts within cores; glazed facades.

### SECTION 1

(50 marks)

- a. Prepare a design appraisal with appropriate sketches indicating two distinct and viable solutions for the proposed structure including the foundations. Indicate clearly the functional framing, load transfer, serviceability, and stability aspects of each scheme. Review and critically appraise the schemes, and identify the solution you recommend, giving reasons for your choice. (40 Marks)
- b. After completion of the design and before construction has started, the Client informs you that the area designated for open-air parking at the front of the building will instead be landscaped, and asks you to incorporate a basement under the full plan area of the building, to accommodate parking for 100 cars. Write a letter to the Client explaining the implications on your design. (10 marks)

### SECTION 2

(50 marks)

For the solution recommended in Section 1(a):

- c. Prepare sufficient design calculations to establish the form and size of all the principal structural elements including the foundations. (20 marks)
- d. Prepare general arrangement drawings which may include plans, sections and elevations to show the dimensions, layout and disposition of the structural elements and critical details for estimating purposes. (20 marks)
- e. Prepare a detailed method statement for the safe construction of the building and an outline construction programme, including consideration of any temporary works that may be required) (10 marks)

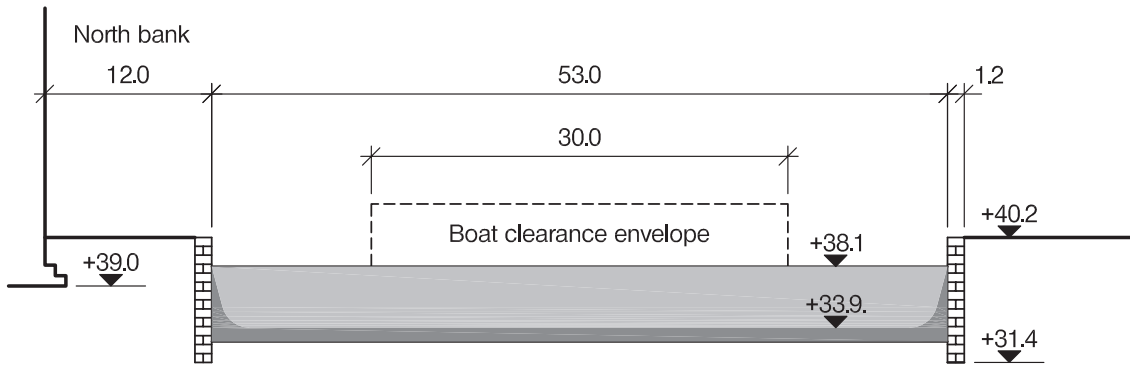

SECTION THROUGH THE SITE

NOTE: All dimensions are in metres

FIGURE Q3



## Question 3. Canal Footbridge

### Client's requirements

1. A footbridge to link a commercial office development to a retail park, across a working canal. The link is expected to be highly trafficked by pedestrians and cyclists. Disabled access is required. See Figure Q3.
2. The minimum canal boat clearance envelope is 30.0m wide x 4.50m high, positioned in the centre of the canal.
3. The existing stone canal walls and impermeable clay lining must not be loaded or damaged by the new construction.
4. The South bank is adjacent to a public park, so there are no space restrictions. There is a building located 12.0m from the canal wall at the North bank.
5. A 2.0m wide towpath should be maintained throughout construction along both banks of the canal.

### Imposed Loading

6. Vertical imposed load of 5.0 kN/m<sup>2</sup> on walkways with a horizontal load of 0.50kN/m on edge protection.

### Site Conditions

7. The site is located in a city centre. The basic wind speed is 46m/s based on a 3-second gust; the equivalent mean hourly wind speed is 23m/s.
8. Ground conditions:
 

0 - 0.8m	Made ground
0.8 - 4.4m	Silty Sand, N = 12
4.4 - 8.8m	Dense sand, N = 22
8.8 - 11.8m	Dense gravelly sand, N = 38
11.8m	Sandstone, compressive strength 2,800 kN/m <sup>2</sup>

 Groundwater was located at 0.85m below ground level.

### Omit from consideration

9. Detailed design of handrails.

### SECTION 1

**(50 marks)**

- a. Prepare a design appraisal with appropriate sketches indicating two distinct and viable solutions for the proposed structure including the foundations. Indicate clearly the functional framing, load transfer, serviceability, and stability aspects of each scheme. Review and critically appraise the schemes, and identify the solution you recommend, giving reasons for your choice. (40 marks)
- b. During foundation excavation an area of archaeological interest is discovered at the location of the North bank foundation, over an area of 4.0m x 4.0m. Write a letter to the Client explaining how the bridge may be completed in its original position but retaining the finds in the ground, for display to the public. (10 marks)

### SECTION 2

**(50 marks)**

For the solution recommended in Section 1(a):

- c. Prepare sufficient design calculations to establish the form and size of all the principal structural elements including the foundations. (20 marks)
- d. Prepare general arrangement drawings, which may include plans, sections and elevations, to show the dimensions, layout and disposition of the structural elements and critical details for estimating purposes. (20 marks)
- e. Prepare a pictorial outline construction sequence for the safe construction of the works, including details of any temporary works that are required. (10 marks)

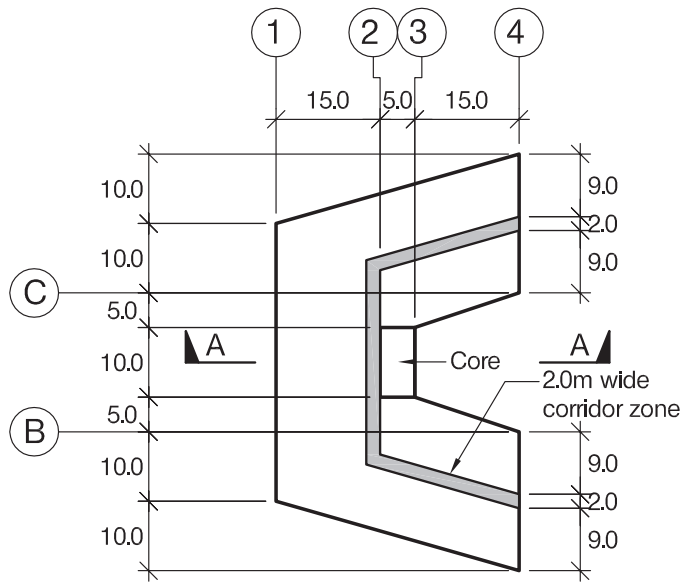

PLAN - Levels 4 - 9

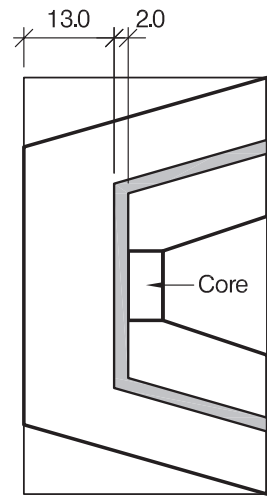

PLAN - Level 3

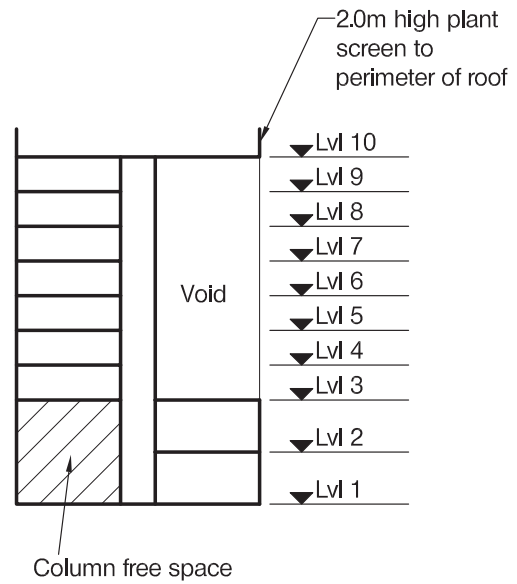

SECTION A - A

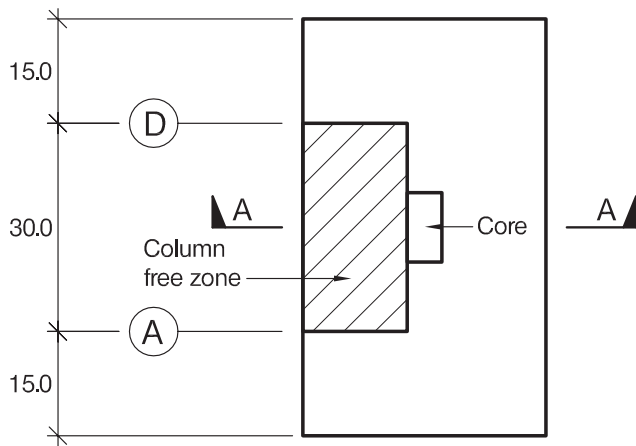

PLAN - Level 1

NOTE: All dimensions are in metres

FIGURE Q4

## Question 4. City-centre Hotel

### Client's requirements

1. A new city-centre 9-storey hotel building; see Figure Q4.
2. The roof will be used to support plant equipment, to be concealed behind a 2.0m high screen.
3. The building will have full-height glazed cladding to the perimeter above Level 3, and between grids A to D on Levels 1 and 2. No bracing is allowed where there is glazed cladding.
4. Internal floor-to-floor heights are to be kept to a minimum to minimise cladding costs. Floor-to-ceiling heights are to be 2.3m, except on Levels 1 and 2 where the floor-to-ceiling height is to be 4.0m. A 250mm-deep service zone should be included within the ceiling voids. No structure is allowed within the service zone.
5. A 2.0m-wide corridor zone is required on Levels 3 to 9 – See Figure Q4. No vertical structure is permitted within the corridor zones.
6. A single stair/lift core extends the full height of the building and may be used for stability design.
7. There is a double-height area on Level 1 – See Figure Q4. No columns are permitted within this zone.
8. A minimum fire rating of 2 hours is required throughout.

### Imposed Loading

9. Roof 10kN/m<sup>2</sup> (Plant)  
Levels 1-9 4kN/m<sup>2</sup>  
Loadings include allowances for floor finishes, ceilings and services

### Site Conditions

10. The site is in a city centre. The basic wind speed is 40m/s based on a 3-second gust; the equivalent mean hourly wind speed is 20 m/s.

### Ground Conditions

11. Ground level – 1.0m Top soil/made ground  
1.0m – 4.0m Sands and Gravels, N = 20 to 30  
Below 4.0m Clay to depth,  $C = 45 + 5z$  kN/m<sup>2</sup>, where  $z$  = depth below top of clay  
Groundwater was encountered at 2.0m below ground level

### Omit from consideration

12. Detailed design for staircases and lifts within cores. Glazed façade

### SECTION 1

**(50 marks)**

- a. Prepare a design appraisal with appropriate sketches indicating two distinct and viable solutions for the proposed structure including the foundations. Indicate clearly the functional framing, load transfer, serviceability and stability aspects of each scheme. Review and critically appraise the schemes, and identify the solution you recommend, giving reasons for your choice. (40 marks)
- b. After completion of the design and before construction has started, the Client states that they may wish to infill the void area above level 3 bounded by grids 3-4 and B-C. Write a letter to the Client advising them of the implications on the design. (10 marks)

### SECTION 2

**(50 marks)**

For the solution recommended in Section 1(a):

- c. Prepare sufficient design calculations to establish the form and size of all the principal structural elements including the foundations. (20 marks)
- d. Prepare general arrangement drawings, which may include plans, sections and elevations, to show the dimensions, layout and disposition of the structural elements and critical details for estimating purposes. (20 marks)
- e. Prepare a detailed method statement for the safe construction of the building and an outline construction programme. (10 marks)

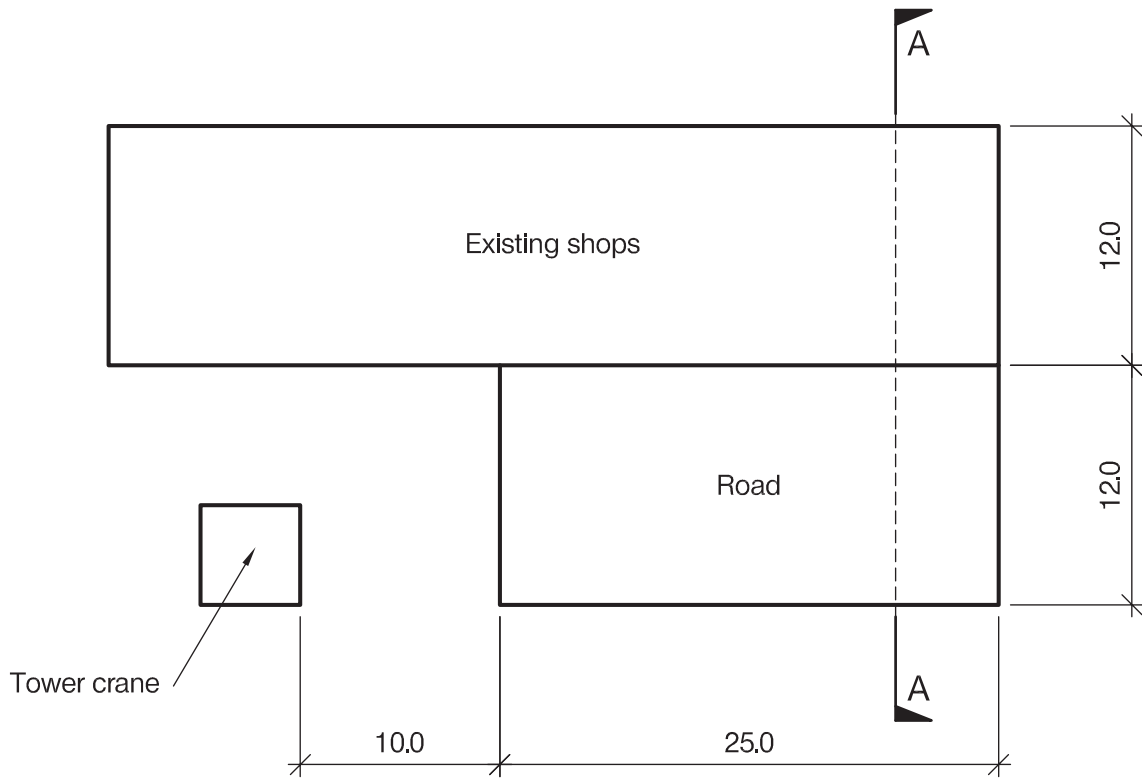

PLAN

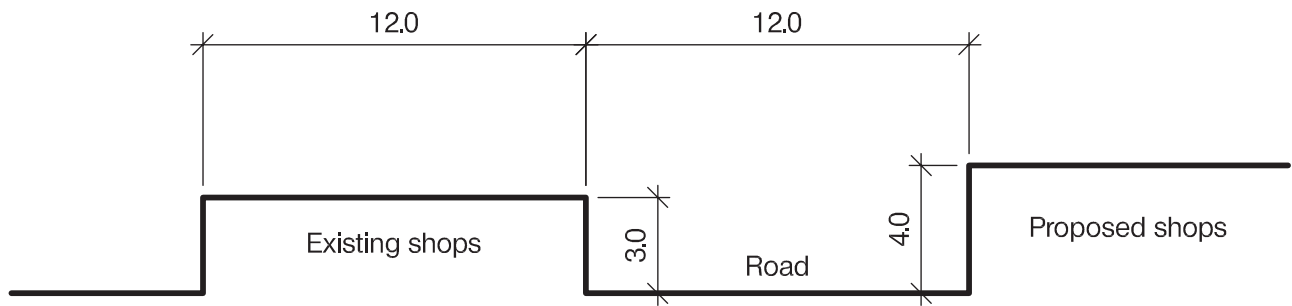

SECTION A - A

NOTE: All dimensions are in metres

FIGURE Q5

## Question 5. Temporary Site Offices

### Client's requirements

1. Temporary site offices for the construction of a large development. See Figure Q5.
2. A total floor area of offices of 1,000m<sup>2</sup> is required. Offices are to have a minimum clear height between floor and ceiling of 2.5m.
3. The offices are to be placed on an existing road that will be closed for the duration of the project. The offices, together with any foundations, must be removed after the project is completed.
4. There are no restrictions on the height of the offices but all levels must be accessible by stairs.
5. New single-storey shops will be constructed along one side of the road. On the opposite site there are existing single-storey shops. Although these shops are to remain open during the construction of the development, no access is required to the shops from the road. See Figure Q5. No loads are to be placed on the existing or proposed shops.
6. A tower crane with reach over the road and a capacity of 10 tonnes is available to use for the construction of the site offices.

### Imposed Loading

- |                 |                      |
|-----------------|----------------------|
| 7. Roof loading | 0.5kN/m <sup>2</sup> |
| Office Loading  | 2.5kN/m <sup>2</sup> |

### Site Conditions

8. The site is located in a city-centre location. The basic wind speed is 46m/s based on a 3-second gust; the equivalent mean hourly wind speed is 23m/s.
9. Tests indicate that the road surface may safely support 100kN/m<sup>2</sup>

### Omit from consideration

10. Detailed design of access stairs. Design of new shops.

### SECTION 1

**(50 marks)**

- a. Prepare a design appraisal with appropriate sketches indicating two distinct and viable solutions for the proposed structure including the foundations. Indicate clearly the functional framing, load transfer, serviceability, and stability aspects of each scheme. Review and critically appraise the schemes, and identify the solution you recommend, giving reasons for your choice. (40 marks)
- b. After the completion of the project the Client wishes to re-use the offices on a site prone to flooding to a depth of 3.0m. The offices can be made watertight during periods of flooding. Write a letter to the Client advising them of the feasibility of re-using the offices in this way. (10 marks)

### SECTION 2

**(50 marks)**

For the solution recommended in Section 1(a):

- c. Prepare sufficient design calculations to establish the form and size of all the principal structural elements including the foundations. (20 marks)
- d. Prepare general arrangement drawings, which may include plans, sections and elevations, to show the dimensions, layout and disposition of the structural elements and critical details for estimating purposes. (20 marks)
- e. Prepare a detailed method statement for the safe construction of the offices and an outline construction programme which should include consideration of any temporary works that may be required. (10 marks)



Blank Page





Blank Page





The Institution of Structural Engineers  
International HQ  
47-58 Bastwick Street  
London, EC1V 3PS  
United Kingdom  
tel: +44 (0)20 7235 4535  
mail@istructe.org  
www.istructe.org  
Registered Charity

