

Associate-Membership Examination

Friday 8 July 2016

Structural Engineering Design and Practice

09.30 – 13.00 and 13.30 – 17.00 (Discussion between individuals is not permitted during lunch period). A period of fifteen minutes is provided for reading the question paper, immediately before the commencement of the examination. Candidates are not permitted to write in answer sheets, or on drawing paper or to use a calculator during this time. Candidates must satisfy the Examiners in ONE question.

Important

The written answer to the question selected and any A3 drawings must bear the candidate's number and the question number at the bottom of the page. Only the answer sheets supplied by the Institution may be used. The candidate's name should not appear anywhere in the script.

Notes to Candidates

1. TO PASS THE EXAMINATION, CANDIDATES MUST SATISFY THE EXAMINERS IN BOTH PARTS OF THE QUESTION ATTEMPTED.
2. Examiners will only mark work written by hand during the examination.
3. A fair proportion of marks will be awarded for the demonstration of an understanding of fundamental engineering concepts, as distinct from calculation of member forces and sizes. NOTE: In the calculation part of all questions, establishing "form and size" is taken to mean compliance with all relevant design criteria, i.e. bending, shear, deflection, etc.
4. In all questions 30 marks are allocated to Section 1 and 70 marks to Section 2.

5. The Examiners are looking for sound structural designs. It should also be remembered that aesthetics, economy and function are important in any competent engineering scheme.
6. Any assumptions made and the design data and criteria adopted must be stated.
7. Good clear drawings and sketches are required; they should show all salient and structural features to suitable scales and should incorporate adequate details.
8. Candidates will not be allowed to include any previously prepared calculations, notes, sketches, diagrams, computer output or other similar material in their answer sheets or A3 drawings. Any previously prepared information submitted by candidates will be ignored by the examiners.
9. Candidates may not bring into the examination room any electronic devices capable of wireless communication, optical photography or scanning.

The following devices are not permitted: Mobile phones, Laptops, notebooks or portable computers and similar devices, iPads, tablets and similar devices, E-readers (e.g. Kindle) and similar devices, Cameras, optical scanners and similar devices.

Any candidates arriving at the examination room with such devices will be asked to switch them off and place them in a sealed bag kept by the Invigilator for the duration of the exam, which includes the lunch period.

10. This paper is set in SI Units.

Now read 'Reminder' on page 3.

Associate-Membership Examination, a reminder from your Examiners

The work you are about to start has many features in common with other examinations which you have tackled successfully but it also has some which are unusual.

As in every examination you must follow carefully the NOTES FOR CANDIDATES set out for your guidance on the front cover of this paper; allocate the available time sensibly and set out your work in a logical and clear way.

The unusual requirement of the examination is that you demonstrate the validity of the training and experience that you have acquired in recent years.

The Institution must be satisfied that you are able to bring all the various skills you are expected to possess to the effective solution of structural design problems whether or not the problem is presented in terms that are within your actual experience.

Incorporated Structural Engineers must have the ability to design and a facility to communicate their design intentions. Where you are required to describe structural solutions you must show by brief, clear, logical and systematic presentation that you understood the general structural engineering principles involved.

In selecting and developing your design you should also remember the guidance given in the Institution's report, Aims of Structural Design, and in particular:

- (1) "the structure must be safe",
- (2) "a good design has certain typical features – simplicity, unity and necessity",
- (3) "the structure must fulfil its intended function".

If you have difficulty in deciding the correct interpretation of a question, pay particular attention to point 6. notes to candidates, on the front cover. The examiners will take into account your interpretation – and the design you base on this – if this is clearly stated at the beginning of your answer.

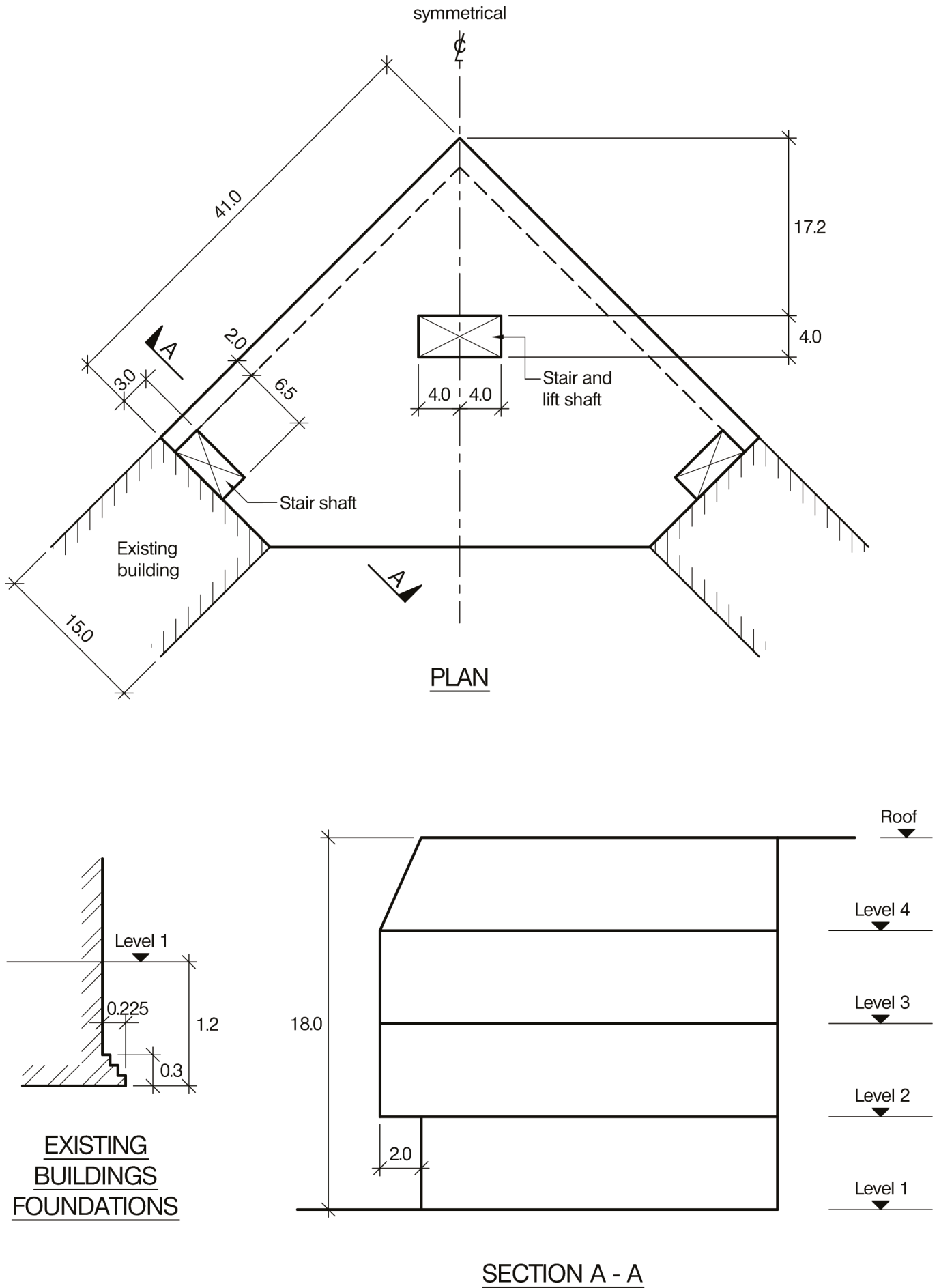

NOTE: All dimensions are in metres

FIGURE Q1

Question 1. Showroom and office development

Client's requirements

1. A new four storey triangular shaped ground floor showroom and office development above located on a corner plot adjacent to existing buildings. See Figure Q1.
2. No foundations are to be installed within 2.0m of the existing buildings.
3. No columns are permitted within the 2.0m building setback between Level 1 and Level 2.
4. The centres of the perimeter columns are to be at a minimum spacing of 6.0m and the internal columns are to be at a minimum spacing of 4.5m.
5. The showroom and offices are to have an internal floor to ceiling height of 3.0m. The overall floor depths at Level 2 and above are to include a 150mm raised floor and 450mm deep service zone between the ceiling and the underside of the floor construction.
6. The external cladding is to be glass curtain walling and the roof is to be flat.

Imposed loading

7. Roof 1.50kN/m²
 Floors 4.00kN/m²
 Imposed loadings include allowances for finishes, services and partitions.

Site conditions

8. The site is level and located in the centre of a town.
9. Basic wind speed is 42m/s based on a 3 second gust; the equivalent mean hourly wind speed is 21m/s.
10. Ground conditions:

Ground level – 1.5m	Made ground
1.5m – 3.5m	Loose sand, N = 5
3.5m – 8.0m	Sand, N = 10
Below 8.0m	Sandstone, allowable bearing capacity 1500kN/m ²

 Ground water was encountered at 3.0m below ground level.

Omit from consideration

11. Detail design of the stair and lift shafts, although their contribution (if any) to the overall stability and load transfer must be stated in Section 1(a).

SECTION 1

(30 marks)

- a. Prepare a design appraisal with appropriate sketches indicating a viable structural solution for the proposed scheme. Indicate clearly the functional framing, load transfer and stability aspects of the scheme. Justify the reasons for the solution. (20 marks)
- b. The client proposes after completion of the design and before construction that only one row of columns is permitted in the showroom at Level 1. Explain the effect this will have on the design and outline any resulting changes to your original proposal. (10 marks)

SECTION 2

(70 marks)

For the solution recommended in Section 1(a):

- c. Prepare sufficient design calculations to establish the form and size of the principal structural elements including the foundations. (30 marks)
- d. Prepare general arrangement plans, sections and elevations to show the dimensions, layout and disposition of the structural elements for estimating purposes. Prepare clearly annotated sketches to illustrate details of:
 - (i) The perimeter columns and floor construction at Level 2 at the setback.
 - (ii) A perimeter column at Level 1. (30 marks)
- e. Prepare a detailed method statement for the safe construction of the building. (10 marks)

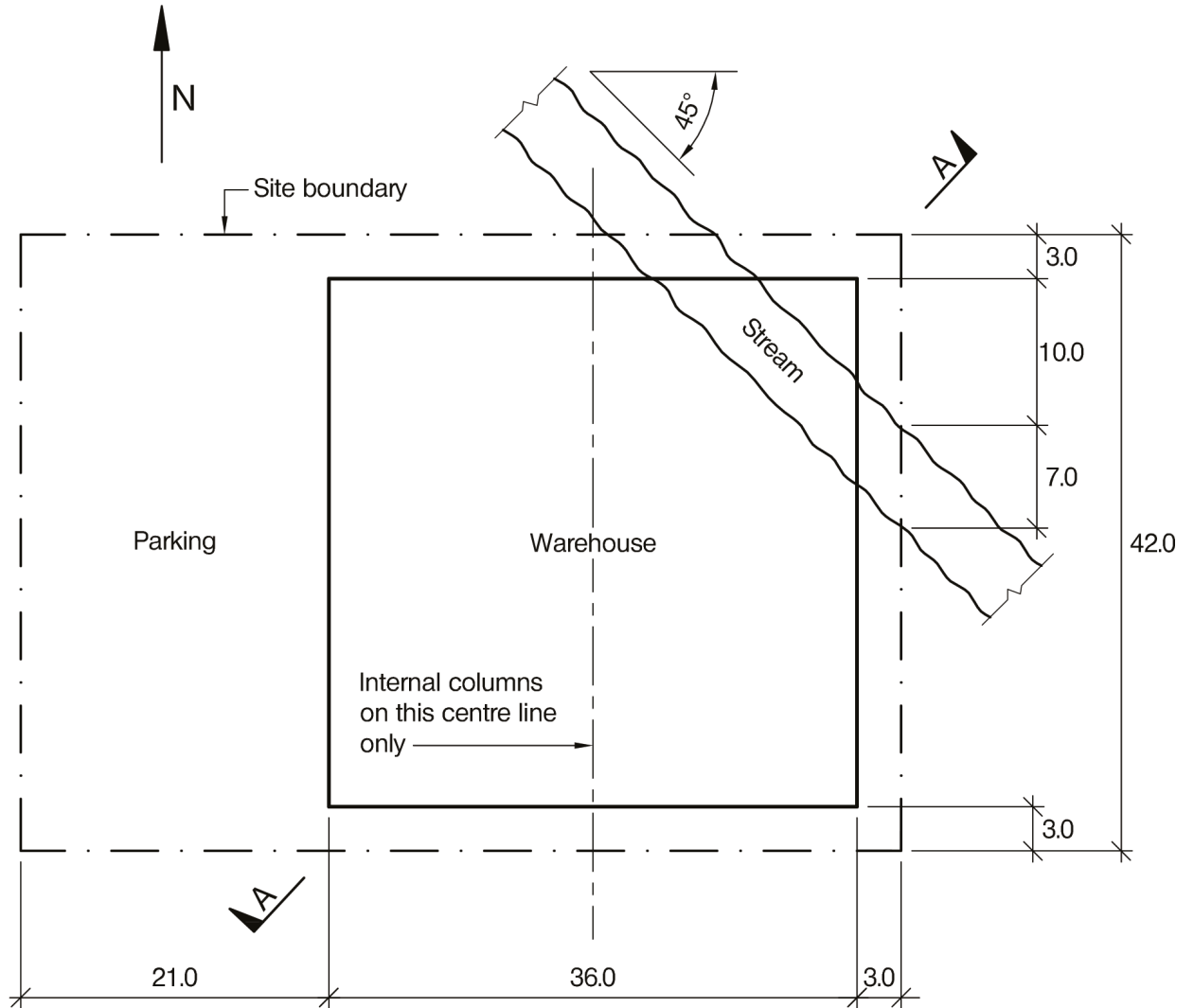

PLAN

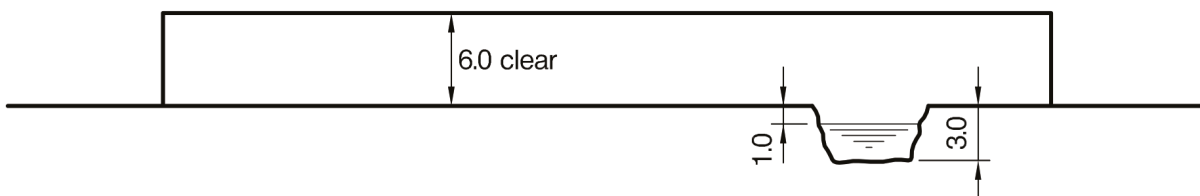

SECTION A - A

NOTE: All dimensions are in metres

FIGURE Q2

Question 2. Retail distribution warehouse

Client's requirements

1. A single storey warehouse is required on a mixed use site for a retailing company. See Figure Q2.
2. As a condition of the planning consent the building must be placed at the east end of the site to allow an area for parking to be used by an adjoining church on Sundays. As a consequence the building will need to be located over a stream, which runs across the northeast corner of the site.
3. The plan dimensions of the warehouse are 36m by 36m. There must only be one row of internal columns, placed along the building centreline. To provide sufficient working headroom for fork lift trucks the clear headroom from floor to lowest part of roof structure is to be 6m.
4. The client asks that the building look functional and would not object to seeing structure expressed externally.
5. The building is to be clad in a flat composite cladding system and the roof is to be clad with composite profile sheeting.

Imposed loading

6.

Roof	1.50kN/m ²
Floors	10.00kN/m ²

Also a 20.00kN point load applied anywhere on the floor to represent loading from a fork lift truck
Imposed loading includes allowances for finishes and services.

Site conditions

7. The site is level and open and at the edge of a city.
8. Basic wind speed is 42m/s based on a 3 second gust; the equivalent mean hourly wind speed is 21m/s.
9. Ground conditions:

Ground level – 1.5m	Vegetation and topsoil
1.5m – 30m	Clay with cohesion varying linearly from $C = 50\text{kN/m}^2$ at a depth of 1.5m to $C = 200\text{kN/m}^2$ at a depth of 30m

The highest recorded ground water level is at ground level.

Omit from consideration

10. Design of the roof and wall cladding panels which may be assumed to be capable of spanning 3.0m.

SECTION 1

(30 marks)

- a. Prepare a design appraisal with appropriate sketches indicating a viable structural solution for the proposed scheme. Indicate clearly the functional framing, load transfer and stability aspects of the scheme. Justify the reasons for the solution. (20 marks)
- b. During the design period the client asks if it would be possible to use the stream to generate electricity for the warehouse. Describe possible options to achieve this and how these would affect the design of the building, using sketches as necessary to illustrate your response. (10 marks)

SECTION 2

(70 marks)

For the solution recommended in Section 1(a):

- c. Prepare sufficient design calculations to establish the form and size of the principal structural elements including the foundations. (30 marks)
- d. Prepare general arrangement plans, sections and elevations to show the dimensions, layout and disposition of the structural elements for estimating purposes. Prepare clearly annotated sketches to illustrate details of:
 - (i) The connection between a typical perimeter column and its foundation including attachment of cladding and allowance for adjustment of line and level of the column.
 - (ii) A cross section through the structure containing the stream including reinforcement detailing. (30 marks)
- e. Prepare a method statement for the safe construction of the structure containing the stream including any temporary measures required. (10 marks)

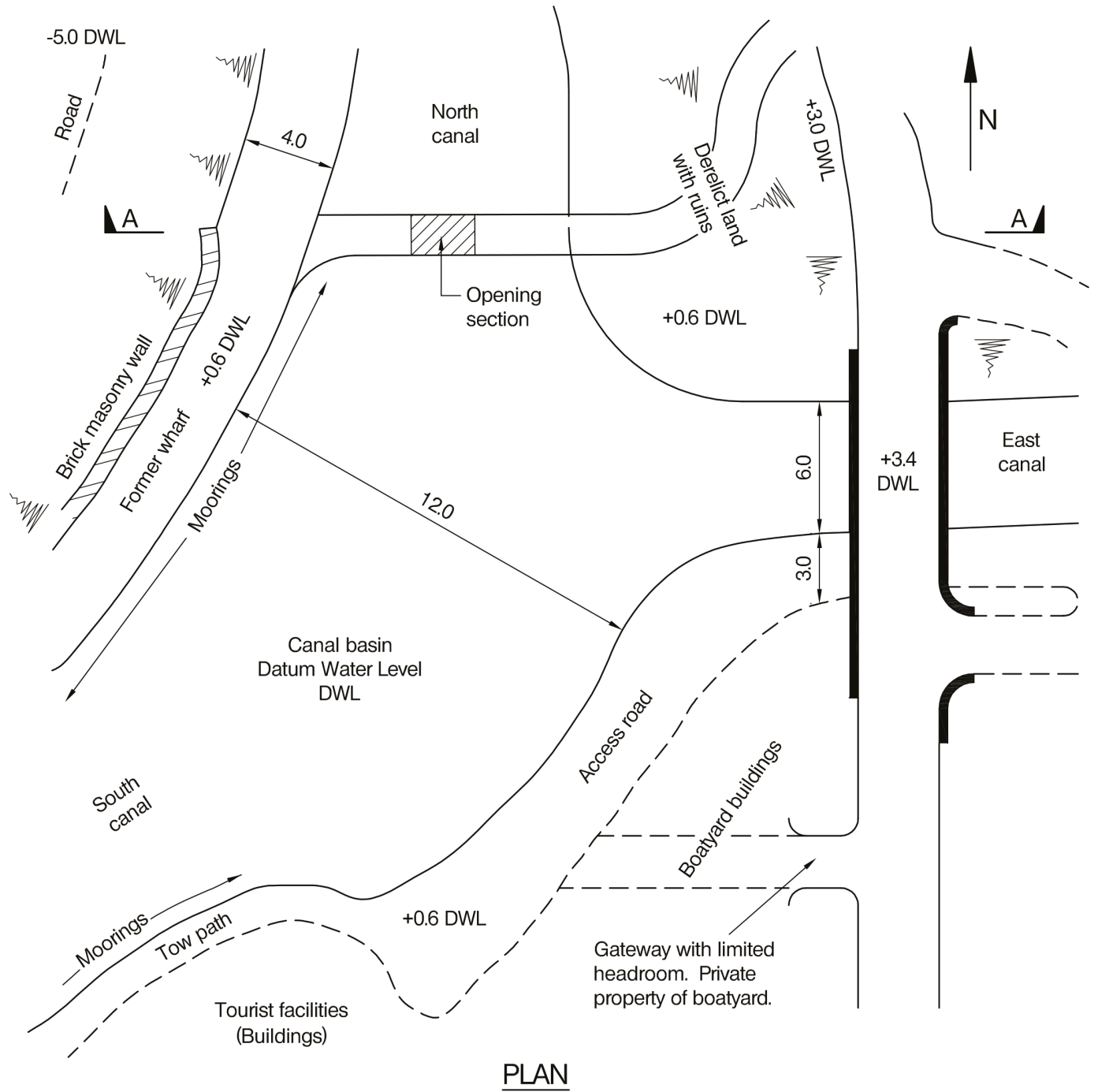

PLAN

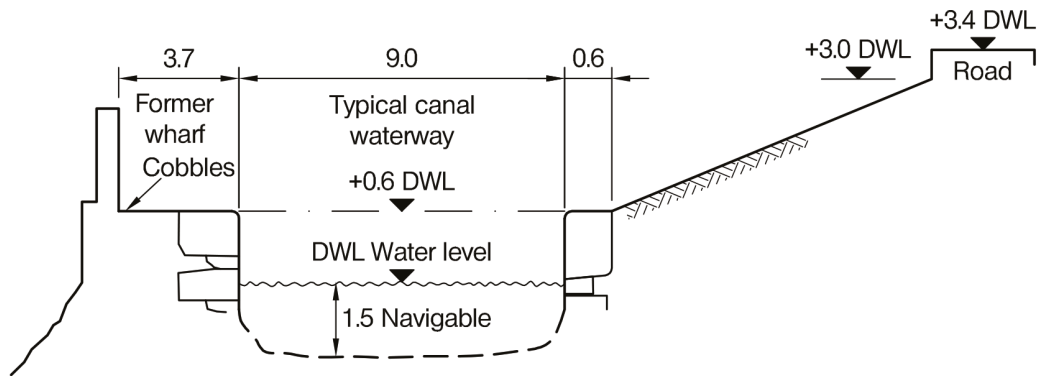

SECTION A - A

NOTE: All dimensions are in metres

FIGURE Q3

Question 3. Canal bridge

Client's requirements

1. A new development is proposed in an ancient town where two canals meet. A planning proposal is required for a minor road bridge that must open to allow barges to pass along the canal. See Figure Q3.
2. The bridge is to be opened manually with the assistance of an overhead counterweight by canal users and then closed after use, in a manner of a traditional Dutch style canal bridge.
3. The minimum waterway width under the opening section of the bridge is 2.1m.
4. A roadway width of 3.7m is required.
5. The bridge will be used to provide access for fire engines to the west side moorings. The maximum height of the fire engine is 3.3m.

Imposed loading

6. Uniformly distributed load	10kN/m ²	
Alternative load from fire engine	Front axle	5.5 tonnes
	Rear axle	6.1 tonnes
	Axle spacing	3.81m

Site conditions

7. The town site is located inland.
8. Basic wind speed is 44m/s based on a 3 second gust; the equivalent mean hourly wind speed is 22m/s.
9. Ground conditions:

Ground level – 2.5m	Clay with layers of sand and ash
Below 2.5m	Sandstone with a presumed safe bearing pressure of 2.0MN/m ²

 Groundwater was found at datum level.

Omit from consideration

10. Mechanical features of the opening section of the bridge.

SECTION 1

(30 marks)

- a. Prepare a design appraisal with appropriate sketches indicating a viable structural solution for the proposed scheme. Indicate clearly the functional framing, load transfer and stability aspects of the scheme. Justify the reasons for the solution. (20 marks)
- b. The client asks if, as an alternative, the bridge could be a fixed, rather than opening, with a minimum vertical clearance between the water and the structure of 2.8m. Describe the implication of implementing this alternative. (10 marks)

SECTION 2

(70 marks)

For the solution recommended in Section 1(a):

- c. Prepare sufficient design calculations to establish the form and size of the principal structural elements including the foundations. (30 marks)
- d. Prepare general arrangement plans, sections and elevations to show the dimensions, layout and disposition of the structural elements for estimating purposes. Prepare clearly annotated sketches to illustrate details of:
 - (i) Hinge connection with the counterweight.
 - (ii) Connection between opening span and supporting substructure and foundations. (30 marks)
- e. Prepare a method statement for the safe construction of the bridge. (10 marks)

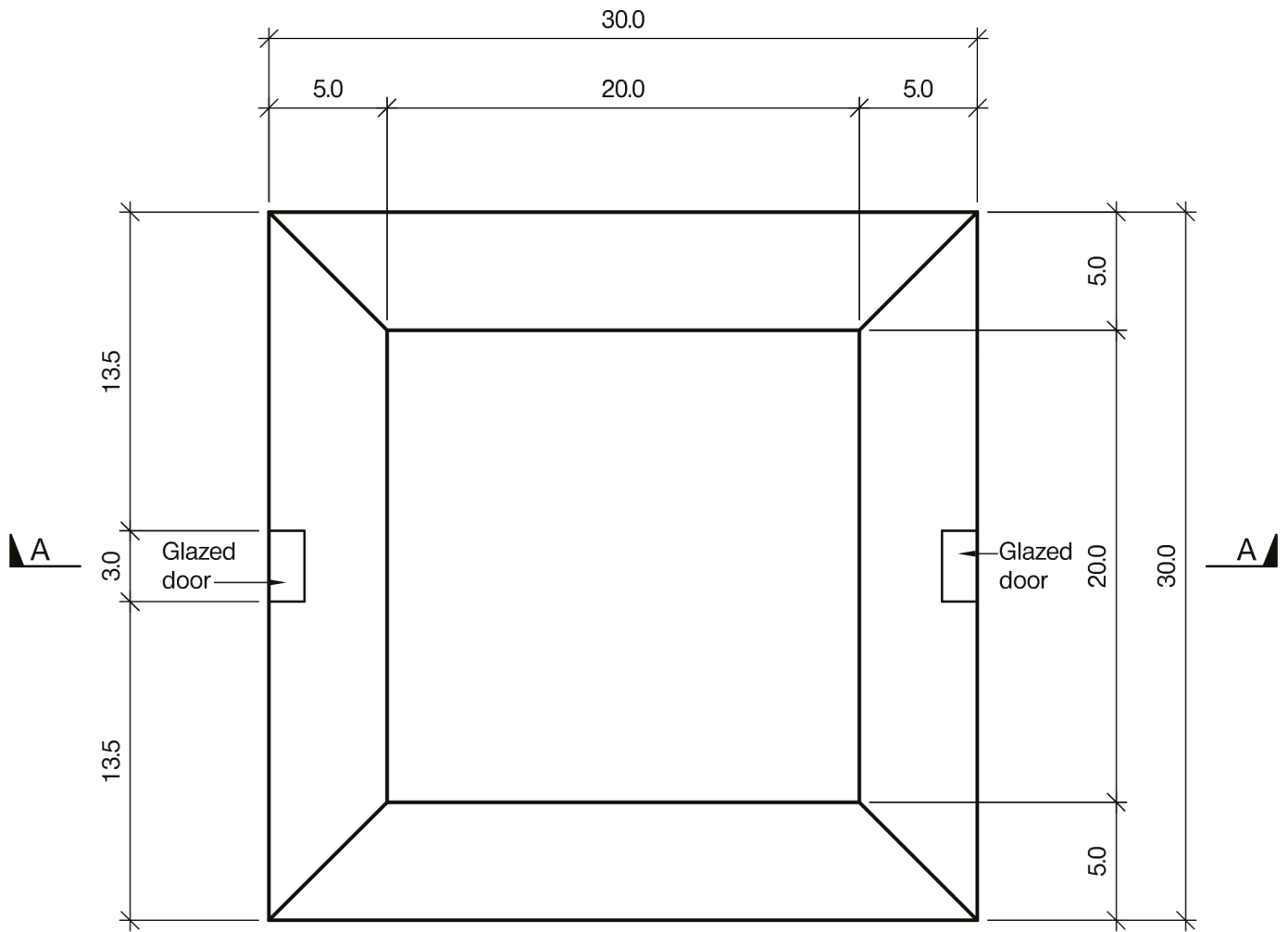

PLAN

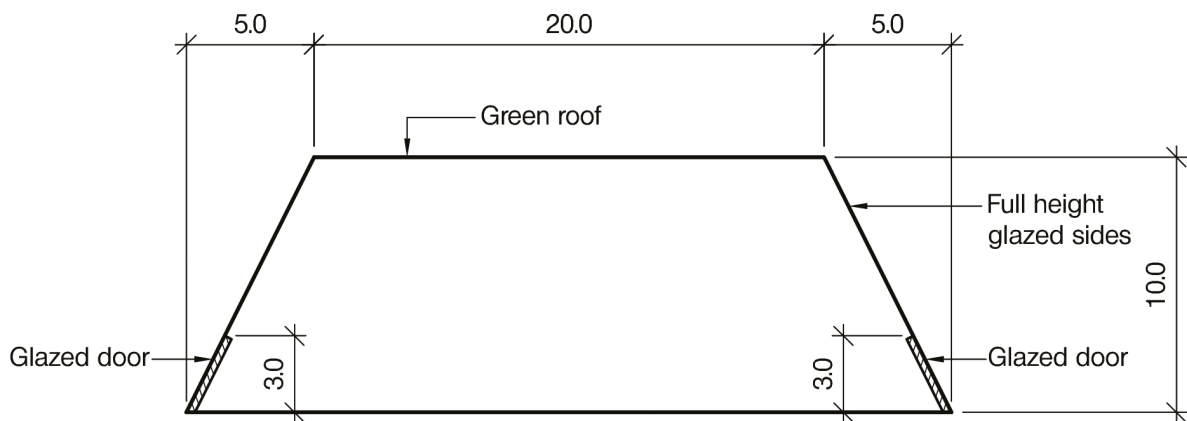

SECTION A - A

NOTE: All dimensions are in metres

FIGURE Q4

The Institution of Structural Engineers
International HQ
47-58 Bastwick Street
London, EC1V 3PS
United Kingdom
tel: +44 (0)20 7235 4535
mail@istructe.org
www.istructe.org
Registered Charity