

# Associate-Membership Examination

Tuesday 18 July 2023

## Structural Engineering Design and Practice

09.30 – 13.00 and 13.30 – 17.00 (Discussion between individuals is not permitted during lunch period). A period of fifteen minutes is provided for reading the question paper, immediately before the commencement of the examination. Candidates are not permitted to write in answer sheets, or on drawing paper or to use a calculator during this time. Candidates must satisfy the Examiners in ONE question.

### Important

The written answer to the question selected and any A3 drawings must bear the candidate's number and the question number at the bottom of the page. Only the answer sheets supplied by the Institution may be used. The candidate's name should not appear anywhere in the script.

### Notes to Candidates

1. TO PASS THE EXAMINATION, CANDIDATES MUST SATISFY THE EXAMINERS IN BOTH PARTS OF THE QUESTION ATTEMPTED.
2. Candidates should note that Figures are produced to illustrate the question and are not necessarily drawn to scale. Figured dimensions should be followed.
3. A fair proportion of marks will be awarded for the demonstration of an understanding of fundamental engineering concepts, as distinct from calculation of member forces and sizes. NOTE: In the calculation part of all questions, establishing "form and size" is taken to mean compliance with all relevant design criteria, i.e. bending, shear, deflection, etc.
4. In all questions 30 marks are allocated to Section 1 and 70 marks to Section 2.

5. The Examiners are looking for sound structural designs. It should also be remembered that aesthetics, economy and function are important in any competent engineering scheme.
6. Any assumptions made and the design data and criteria adopted must be stated.
7. Good clear drawings and sketches are required; they should show all salient and structural features to suitable scales and should incorporate adequate details.
8. Candidates will not be allowed to include any previously prepared calculations, notes, sketches, diagrams, computer output or other similar material in their answer sheets or A3 drawings. Any previously prepared information submitted by candidates will be ignored by the examiners.
9. Candidates may not bring into the examination room any electronic devices capable of wireless communication, optical photography or scanning.

The following devices are not permitted: Mobile phones, Laptops, notebooks or portable computers and similar devices, iPads, tablets and similar devices, E-readers (e.g. Kindle) and similar devices, Cameras, optical scanners and similar devices.

Any candidates arriving at the examination room with such devices will be asked to switch them off and place them in a sealed bag kept by the Invigilator for the duration of the exam, which includes the lunch period.

10. This paper is set in SI Units.

**Now read 'Reminder' on page 3.**



# Associate-Membership Examination, a reminder from your Examiners

The work you are about to start has many features in common with other examinations which you have tackled successfully but it also has some which are unusual.

As in every examination you must follow carefully the NOTES FOR CANDIDATES set out for your guidance on the front cover of this paper; allocate the available time sensibly and set out your work in a logical and clear way.

The unusual requirement of the examination is that you demonstrate the validity of the training and experience that you have acquired in recent years.

The Institution must be satisfied that you are able to bring all the various skills you are expected to possess to the effective solution of structural design problems whether or not the problem is presented in terms that are within your actual experience.

Chartered Structural Engineers must have the ability to design and a facility to communicate their design intentions. Where you are required to list and discuss possible structural solutions you must show by brief, clear, logical and systematic presentation that you understood the general structural engineering principles involved.

In selecting and developing your design you should also remember the guidance given in the Institution's report, Structural design - achieving excellence, and in particular:

- (1) "the structure must be safe",
- (2) "a good design has certain typical features – simplicity, unity and necessity",
- (3) "the structure must fulfil its intended function".

If you have difficulty in deciding the correct interpretation of a question, pay particular attention to point 6. notes to candidates, on the front cover. The examiners will take into account your interpretation – and the design you base on this – if this is clearly stated at the beginning of your answer.

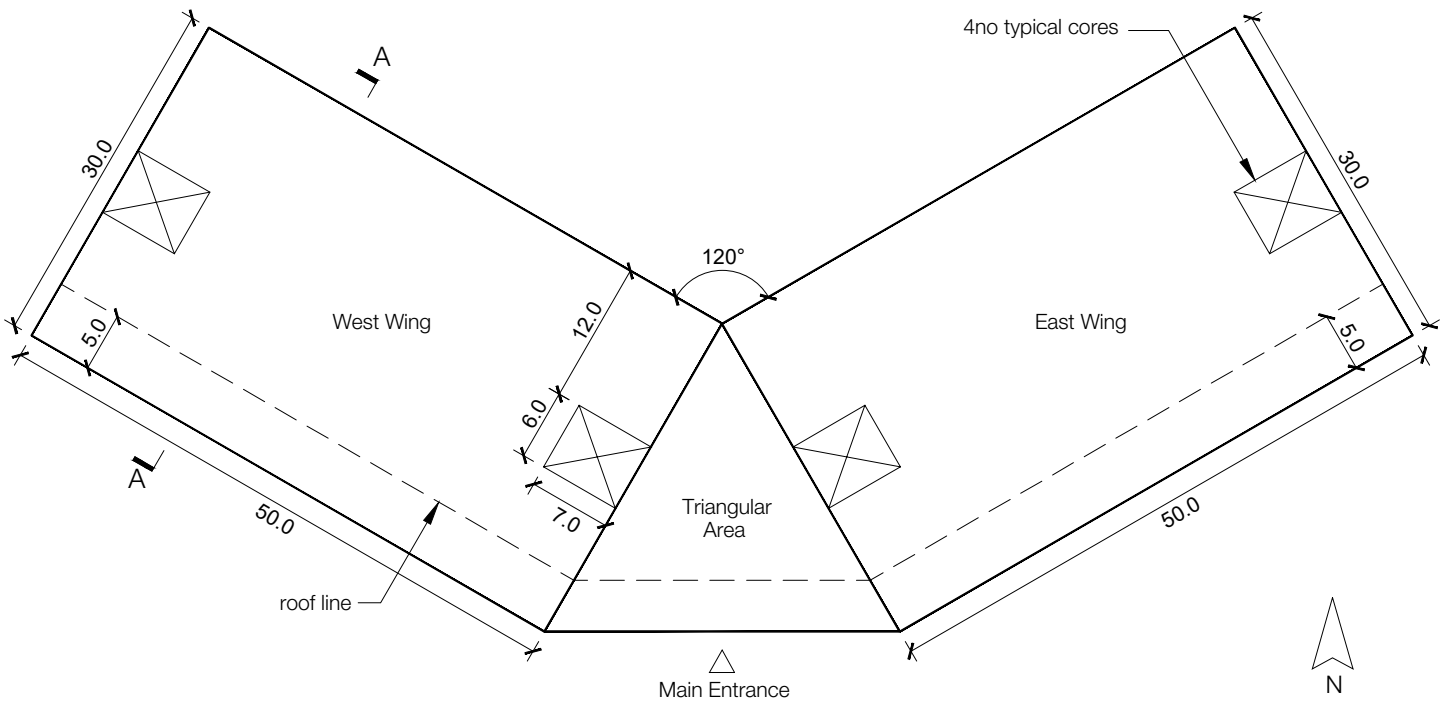

PLAN

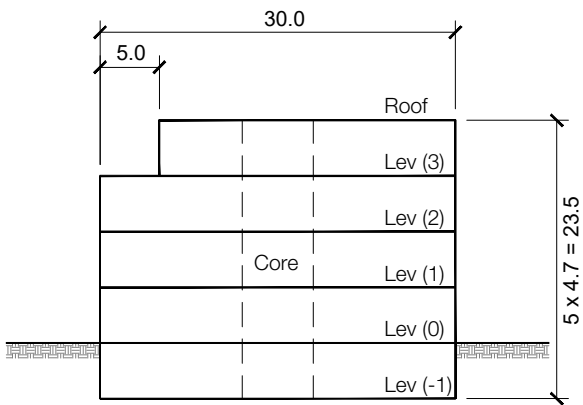

SECTION A-A

NOTE: All dimensions are in metres.

FIGURE Q1

# Q1. Medical Centre Building

## Client's requirements

1. The client requires a new medical centre building on the outskirts of a main city. The building comprises two east and west wings at 120 degrees connected through a triangulated area at the middle and is to be constructed in four levels above the ground with one basement floor, see Figure Q1.
2. The triangular area includes a ground floor (level 0) atrium with main entrance to the building. The top floor (level 3) is setback throughout the south side (both wings and middle triangular section) to accommodate a roof garden 5m wide (measured on plan of wings). The plantroom is located in the basement (level -1).
3. The minimum internal column spacing shall be 7m (excluding distance to core walls) and a maximum of 8 internal columns are permitted in each wing. Columns are permitted around the lift/elevator/stair cores. Columns are permitted on elevations, but no columns shall be visible within a glazed panel.
4. Lift/elevator shafts and stairs are accommodated in 4 core areas as shown in Figure Q1. No other stairs or lifts/elevators are permitted.
5. The minimum clear floor to ceiling height shall be 3m at all levels. A mechanical services zone of minimum 0.50m depth need to be allowed at all levels. The overall height above the ground (level 0) shall not exceed 20m. The floor-to-floor heights are shown in Figure Q1.
6. The building is glazed 50% on south elevations of east and west wings and the south front entrance and 25% elsewhere.
7. No bracings or shear walls are permitted internally; except around lift/elevator/stair cores. Externally no bracings or shear walls are permitted within the glazed panels.
8. The roof is flat with access for maintenance only.
9. A minimum fire resistance period of 2 hours is required for structural elements.

## Imposed loading

|                      |                        |
|----------------------|------------------------|
| 10. Roof             | 1.00 kN/m <sup>2</sup> |
| Floors & roof garden | 5.0 kN/m <sup>2</sup>  |
| Plantroom            | 7.5 kN/m <sup>2</sup>  |

## Site conditions

11. The site is flat. The basic wind speed is 50m/s on a 3-second gust; the equivalent mean hourly wind speed is 25m/s.
12. Ground conditions:
 

|             |                          |
|-------------|--------------------------|
| 0.0m – 1.0m | Made Ground              |
| 1.0m – 3.0m | Medium dense sand (N=22) |
| Below 3.0m  | Dense sand (N=40)        |

Ground water was encountered at 10m below the ground level.

## Omit from consideration

Detailed design of stairs/lifts/elevators, and façade cladding/glazing.

## SECTION 1

**(30 marks)**

- a) Prepare a design appraisal with appropriate sketches indicating a viable solution for the proposed structure including the foundations. Indicate clearly the functional framing, load transfer and stability aspects of the scheme. Justify the reasons for your solution. (20 marks)
- b) After completion of scheme design for the structure, the client enquires if the plantroom can be moved to be on top of the roof. Write a letter to the client, advising on the structural implications of this change with a description of ways to achieve it. (10 marks)

## SECTION 2

**(70 marks)**

For the solution recommended in Section 1(a):

- c) Prepare sufficient design calculations to establish the form and size of all the principal structural elements including the foundations. (30 marks)
- d) Prepare general arrangement drawings, which may include plans, sections and elevations to show the dimensions, layout and disposition of the structural elements for estimating purposes. Prepare clearly annotated sketches to illustrate details of:
  - a) Recessed roof support column and floor connection at Level 3
  - b) Floor construction connection to the external retaining wall at Level 0 (30 marks)
- e) Prepare a detailed method statement for the safe construction of the building (10 marks)

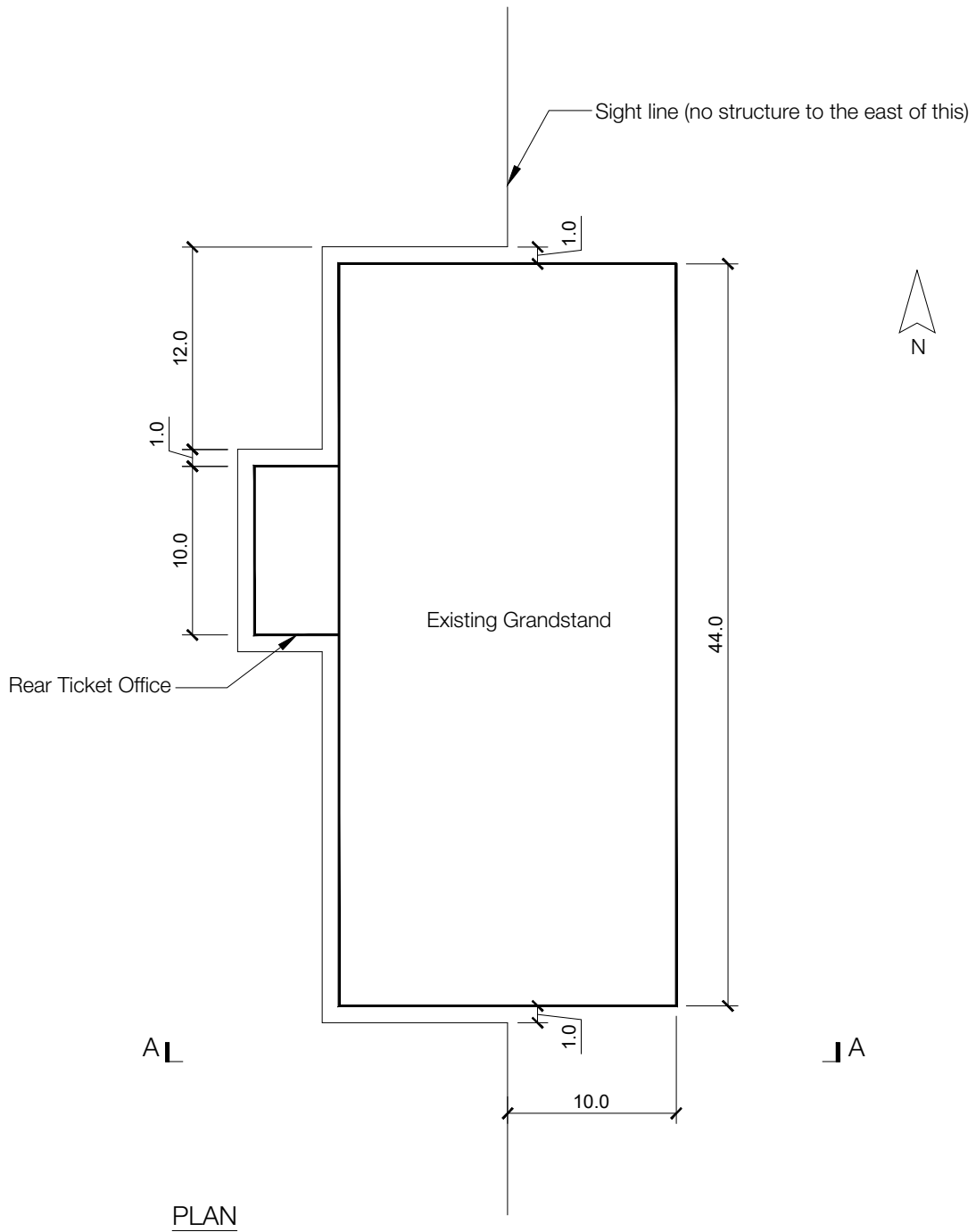

PLAN

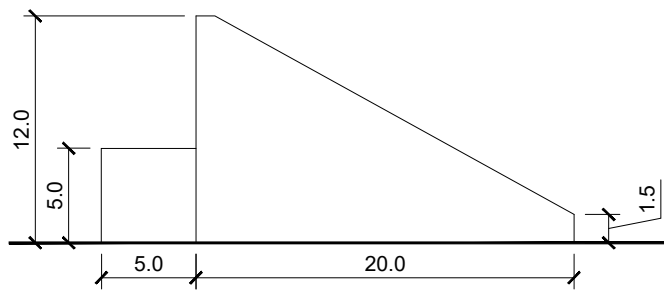

ELEVATION A-A

NOTE: All dimensions are in metres.

FIGURE Q2

## Q2. Grandstand Strengthening

### Client's requirements

1. The owner of an existing uncovered grandstand on the western side of a racetrack wishes to install a new roof canopy that covers the plan extent of the grandstand. No coverage of the rear ticket office is required.
2. The client has requested that attention be paid to the efficiency of the design and seeks a lightweight structure.
3. The existing grandstand structure must be preserved and cannot be used to carry any loads from the new structure, either during construction or in the permanent condition. All proposed structure (including foundations) cannot be closer than 1m to any side of the grandstand. All roof structure over the existing grandstand must be at least 2.4m above the highest part of the existing structure.
4. In order to preserve sight lines within the existing grandstand, no columns supporting the roof, nor their foundations, can project east of the sightline shown on Figure Q2.

### Imposed loading

5. The following loads are to be applied on the roof:
 

|            |  |
|------------|--|
| Live load: | 3.0 kN/m <sup>2</sup> over any 10m x 10m patch |
|            | 1.5 kN/m <sup>2</sup> over any larger patch    |
| Services:  | 0.5 kN/m <sup>2</sup>                          |

### Site conditions

6. The site is flat. The basic wind speed is 44 m/s on a 3-second gust; the equivalent mean hourly wind speed is 22m/s.
7. Ground Conditions:
 

|             |   |
|-------------|---|
| 0.0m – 0.8m | Made Ground   |
| 0.8m – 2.0m | Dense sand and gravel (N=40)                        |
| Below 2.0m  | Sandstone, safe bearing value 900 kN/m <sup>2</sup> |

Ground water was encountered at 3.5m below the ground level.

## SECTION 1

**(30 marks)**

- a) Prepare a design appraisal with appropriate sketches indicating a viable solution for the proposed structure. Indicate clearly the functional framing, load transfer and stability aspects of the scheme. Justify the reasons for your solution. (20 marks)
- b) After the design is complete, the client requests that an information board is to be hung along the central 5 m of the east side of roof weighing 25 tonnes. Write a letter to the client, advising on the structural implications of this change with a description of ways to achieve it. (10 marks)

## SECTION 2

**(70 marks)**

For the solution recommended in Section 1(a):

- c) Prepare sufficient design calculations to establish the form and size of all the principal structural elements including the foundations. (30 marks)
- d) Prepare general arrangement drawings, which may include plans, sections and elevations to show the dimensions, layout and disposition of the structural elements for estimating purposes. Prepare clearly annotated sketches to illustrate details of:
  - a) Connection of the main horizontal to vertical support structure
  - b) The foundations to the new support structure.

(30 marks)
- e) Prepare a detailed method statement for the safe construction of the new structure. (10 marks)

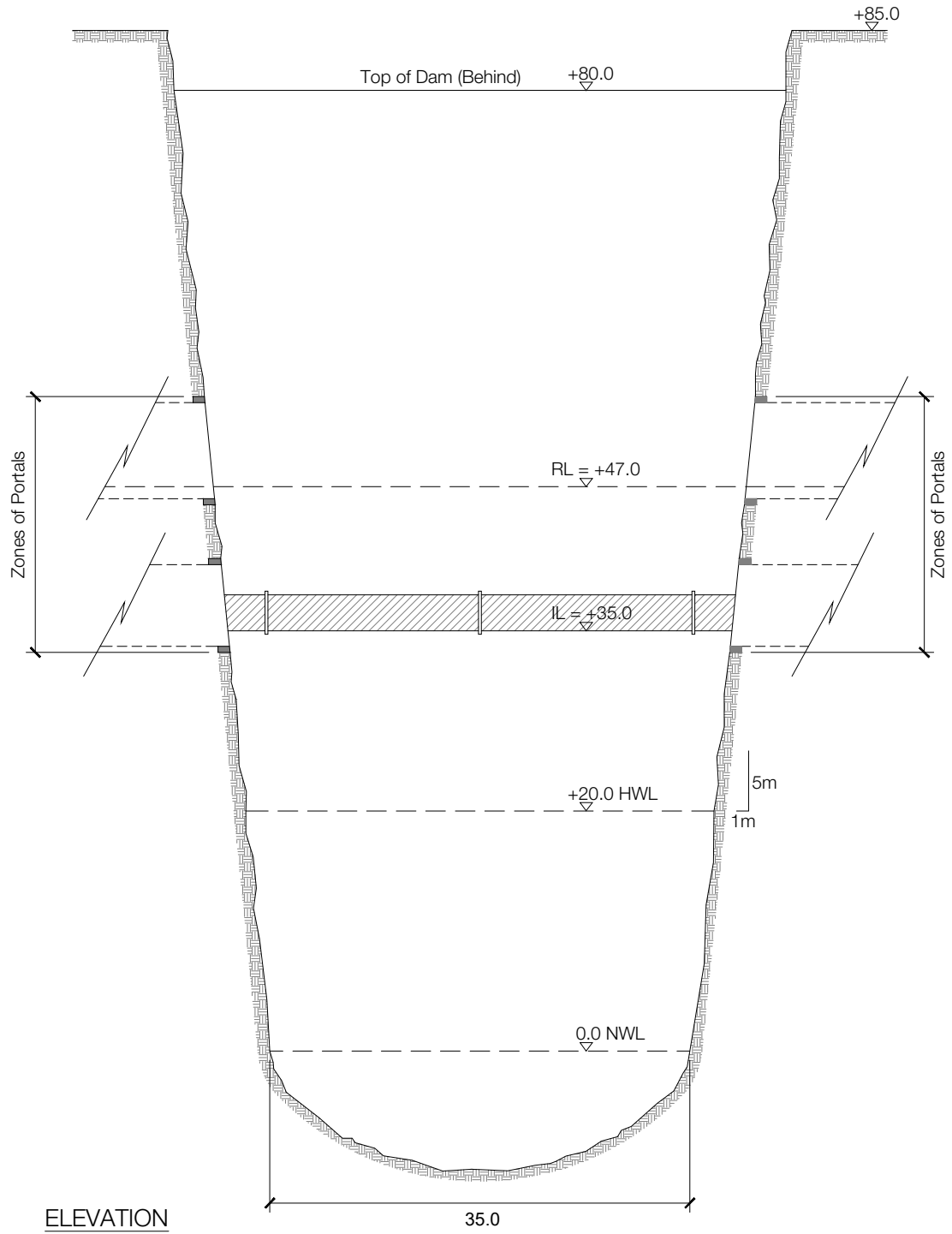

ELEVATION

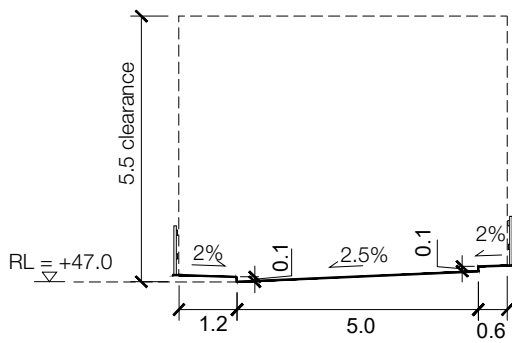

UPPPER LEVEL

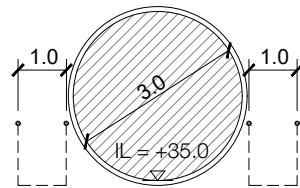

LOWER LEVEL

DECK CROSS SECTIONS

NOTE: All dimensions are in metres.

FIGURE Q3





**Blank page**

## Q3. Water Pipe and Access Road bridge

### Client's requirements

1. The structure is part of a new hydro power plant located in a mountainous region. The bridge is set downstream to a dam and crosses a deep natural gorge between steep rock faces. The structure needs to carry a service road at the upper level and a large carrier pipe full of water at the lower level as shown in Figure Q3.
2. The road deck shall accommodate a 5m wide roadway with pedestrian access provided within 1.2m wide raised footpath on one side and a 0.6m wide raised verge on the opposite side. The edge of the upper deck shall accommodate vehicle containment parapets. A vertical clearance of 5.5m shall be provided above the upper deck.
3. The lower deck shall support a 3m internal diameter carrier pipe that will transport water across the gorge. A 1m wide access walkway with pedestrian handrails shall be positioned on either side of the pipe for inspection and maintenance of the conduit. The structure should have sufficient stiffness to minimise deflections of the carrier pipe under the effects of imposed live loads and remain elastic with maximum midspan deflections to be not greater than 70mm.
4. Access to the bridge decks is from existing tunnels formed into the rock on each side of the gorge.
5. The mountainous access to the site imposes delivery restrictions to the maximum length and sizes of components as 20m long, 3.5m wide and 3.5m tall. The bottom of the gorge contains a narrow river with variable water level. No temporary or permanent construction is permitted below water level.

### Imposed loading

6. Vertical actions on the upper deck to be 10 kN/m<sup>2</sup> over the road and 5 kN/m<sup>2</sup> over the footpath and verge.
7. Self-weight of steel carrier pipe (including saddle supports) to be 15 kN/m.

### Site conditions

8. The site is in a mountainous environment with a basic wind speed is 40 m/s based on a 3 second gust; the equivalent mean hourly wind speed is 20 m/s.
9. Allowable bearing pressure of 1500 kN/m<sup>2</sup> (outside the zone of portals) and allowable skin friction of 100 kN/m<sup>2</sup>. Within the zone of portals (noted in Figure Q3 elevation), the allowable bearing pressure is limited to 250 kN/m<sup>2</sup>.

### Omit from consideration

10. Load effects on existing tunnels linings and portals.

## SECTION 1

**(30 marks)**

- a) Prepare a design appraisal with appropriate sketches indicating a viable solution for the proposed structure including the foundations. Clearly indicate the functional framing, load transfer, serviceability, stability aspects and constructability of the scheme considering the site constraints. Justify the reasons for your solution. (20 marks)
- b) After your recommended solution has been accepted in principle, the Client advises that additional ground investigation identified a fault line at the top of the rock face within 15m from the edge of the right bank. This area is found to be not suitable for heavy construction plants. Write a letter to the Client explaining the design and construction implications using sketches where relevant and advising in which way the design and construction would need to be modified to accommodate this new criterion. (10 marks)

## SECTION 2

**(70 marks)**

For the solution recommended in Section 1(a):

- c) Prepare sufficient design calculations to establish the form and size of all the principal structural elements including the foundations. (30 marks)
- d) Prepare general arrangement drawings which may include plans, sections and elevations to show the dimensions, layout and disposition of the structural elements for estimating purposes. Prepare clearly annotated sketches to illustrate details of:
  - a) Connection of the bridge structure to the foundations
  - b) Support structure for the water carrier pipe (30 marks)
- e. Prepare a detailed method statement for the safe construction of the bridge (10 marks)

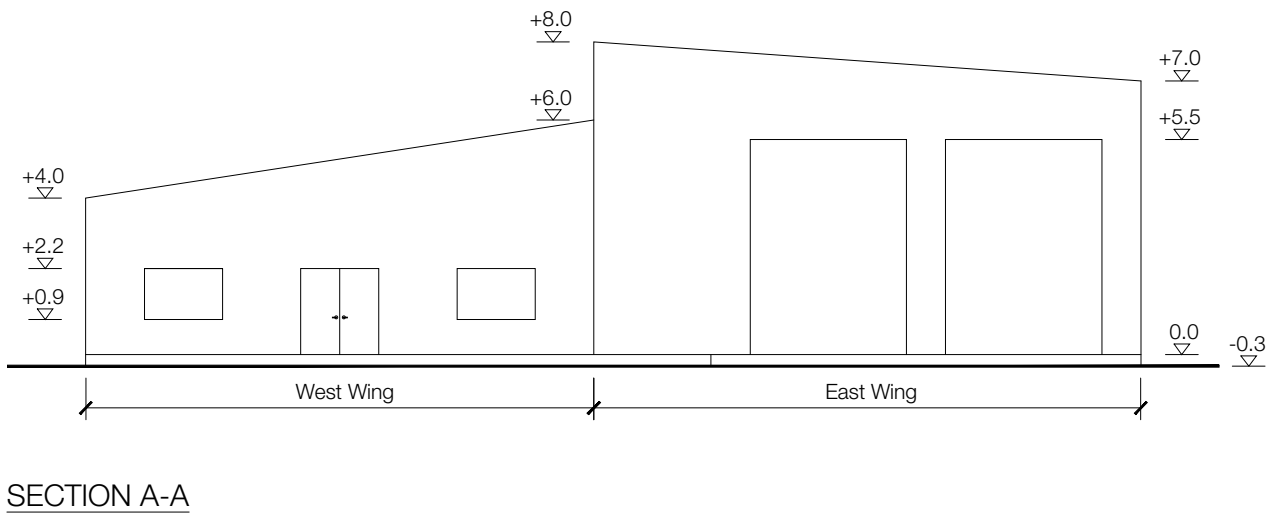
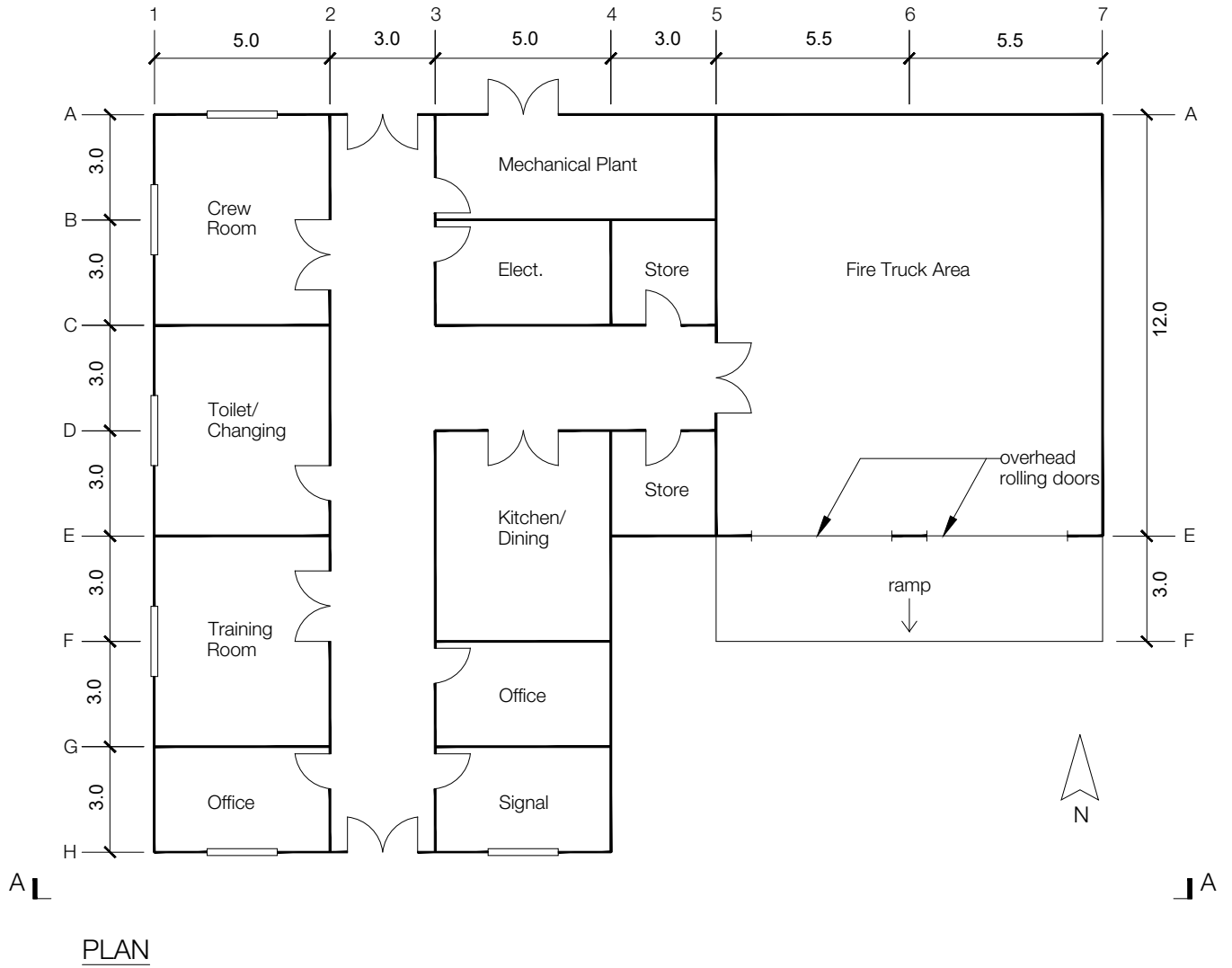

NOTE: All dimensions are in metres.

FIGURE Q4

## Q4. Airport Secondary Fire Station Building

### Client's requirements

1. A secondary fire station building at a regional airport; see Figure Q4.
2. The single storey building comprises two wings. Offices with training and welfare facilities are in the west wing. Garage parking for two fire trucks is located in the east wing; no internal columns are permitted in the fire truck area.
3. Corridors are 3m wide, windows are 2m wide by 1.3m high with windowsills at 0.9m above floor level. Doors are 2.2m high, single doors are 1m wide and double doors 2m wide.
4. A minimum floor to ceiling height of 2.5m is required for the west wing of the building.
5. Two overhead rolling doors to the east wing, each to provide a clear vertical height of 5.5m and a clear width of 4.5m for the fire trucks.
6. The sloping roof is for maintenance access only.
7. Materials for the external envelope of the building are to be selected to minimise energy consumption.
8. The building is to have a 1-hour fire rating. Fire doors are to be provided between the fire truck area and the west wing of the building.

### Imposed loading

|                                     |                        |
|-------------------------------------|------------------------|
| 9. Roof                             | 0.6 kN/m <sup>2</sup>  |
| Ceilings and services               | 0.3 kN/m <sup>2</sup>  |
| West section floors including plant | 5.0 kN/m <sup>2</sup>  |
| Engine enclosure floor              | 10.0 kN/m <sup>2</sup> |

### Site conditions

10. The regional airport is located in an open flat area 16 kilometers from the nearest town.  
Basic wind speed is 44.0m/s based on a 3-second gust; the equivalent mean hourly speed is 22.0m/s.  
Ground conditions
 

|                     |   |
|---------------------|---|
| Ground level – 0.3m | Topsoil   |
| 0.3m – 3.0 m        | Medium SAND and Gravel. N = 15 increasing to 20 with depth. |
| Below 3.0 m         | Stiff Clay. C = 250 kN/m <sup>2</sup> .                     |

 Groundwater was encountered at 2.0m below ground level.

### Omit from consideration

11. Design of roller doors, associated services and the external ramp.

## SECTION 1

**(30 marks)**

- a) Prepare a design appraisal with appropriate sketches indicating a viable solution for the proposed structure including the foundations. Indicate clearly the functional framing, load transfer, serviceability and stability aspects of the scheme. Justify the reasons for your solution. (20 marks)
- b) After the scheme design has been approved, the Client asks if a second floor could be added with clear internal height of 2.5m to the west wing of the building. Write a letter to the Client explaining the implications on your design and on construction. (10 marks)

## SECTION 2

**(70 marks)**

For the solution recommended in Section 1(a):

- c) Prepare sufficient design calculations to establish the form and size of all the principal structural elements including the foundations. (30 marks)
- d) Prepare general arrangement drawings, which may include plans, sections and elevations to show the dimensions and layout of the structural elements for estimating purposes. Prepare clearly annotated sketches to illustrate details of:
  - a) The west wing roof structure at its support with the east wing interface
  - b) The perimeter foundations, ground slab and vertical support structure (30 marks)
- e. Prepare a detailed method statement for the safe construction of the building. (10 marks)

**Blank page**

**Blank page**

---

International HQ,  
47-58 Bastwick Street,  
London EC1V 3PS, UK

**T** +44 (0)20 7235 4535

**E** [membership@istructe.org](mailto:membership@istructe.org)

**[www.istructe.org](http://www.istructe.org)**

---