



**THE M_w 6.4 ALBANIA
EARTHQUAKE ON
THE 26TH NOVEMBER 2019**
A FIELD REPORT BY EEFIT
OCTOBER 2020

THE M_w 6.4 ALBANIA EARTHQUAKE ON THE 26th NOVEMBER 2019

A FIELD REPORT BY EEFIT

Anton Andonov, Mott MacDonald

Stoyan Andreev, Mott MacDonald

Fabio Freddi, University College London

Federica Greco, ARUP

Roberto Gentile, University College London

Viviana Novelli, Cardiff University

Enes Veliu, IUSS Pavia

Field mission conducted with the participation of **Emiljano Zhuleku**, Mott MacDonald Albania

Report reviewed by **Joshua Macabuag** (SERAID UK), **Michael Whitworth** (AECOM), **Diana Contreras Mojica** (Newcastle University), **Matthew Free** (ARUP), **Sean Wilkinson** (Newcastle University)

Earthquake Engineering Field Investigation Team
c/o The Institution of Structural Engineers International HQ
47–58 Bastwick Street
London EC1V 3PS
Email: eefit@istructe.org.uk
Website: <http://www.eefit.org.uk>

October 2020

Contents

Acronyms	1
Acknowledgment	2
Executive summary	3
1 Introduction	4
1.1 The EEFIT Mission	4
1.2 Mission itinerary	6
2 Seismotectonic and geotechnical aspects	8
2.1 Tectonic setting of the region	8
2.2 Historical seismicity in the region	9
2.3 The 2019 earthquake sequence in central Albania	11
2.4 Geotechnical conditions and geohazards	12
2.5 Observed ground failures	14
2.6 References for chapter 2	16
3 Description of the Albanian building stock	18
3.1 Population of Albania	18
3.2 Building stock of Albania	18
3.3 References for chapter 3	22
4 Evolution of Albanian seismic building codes	23
4.1 Seismic design code of 1978, KTP 2-78	23
4.2 Seismic design code of 1989, KTP-N.2-89	27
4.3 The status of Eurocode 8 in Albania	35
4.4 References for chapter 4	35
5 The 26th November 2019 earthquake	37
5.1 Earthquake intensity	37
5.2 Damage and economic losses	40
5.3 Macroeconomic impact	44
5.4 Socio-economic impact	45
5.5 Post-disaster response	47
5.6 Casualty-causing buildings	47
5.7 References for chapter 5	52
6 Damage assessment of the investigated buildings	55

6.1	Approach to damage assessment	55
6.2	Summary of investigated buildings	58
6.3	References for chapter 6	65
7	Case studies	66
7.1	Pre-1990 unreinforced masonry buildings	66
7.2	Pre-1990 prefabricated large-panel buildings	71
7.3	Multi-storey RC buildings	75
7.4	Single-family rural houses	85
7.5	Historical buildings	87
7.6	References for chapter 7	101
8	Final remarks and lessons learned	103

Tables

Table 3.1:	Number of residential buildings by year of construction and the main material type according to INSTAT 2001	19
Table 3.2:	Number of residential buildings by construction year and number of stories	21
Table 4.1:	Seismic design codes of Albania and corresponding enforcement period	23
Table 4.2:	Seismic coefficient K_e , given in KTP 2-78	25
Table 4.3:	Maximum height, H , and slenderness ratio H/a where a is the wall thickness, of walls according to KTP 2-78	26
Table 4.4:	Seismic strength categorization of walls according to KTP 2-78	26
Table 4.5:	Seismic coefficients according to KTP-N.2-89	29
Table 4.6:	Dynamic response factor ψ of buildings according to KTP-N.2-89	29
Table 4.7:	Dynamic factor β , according to KTP-N.2-89	29
Table 4.8:	Seismic strength categorization of walls according to KTP-N.2-89	30
Table 4.9:	Maximum allowable storey heights according to KTP-N.2-89	30
Table 4.10:	Maximum spacing between transverse walls according to KTP-N.2-89	30
Table 4.11:	Detailing rules for RC columns in KTP-N.2-89	31
Table 4.12:	Detailing rules for RC beams according to KTP-N.2-89	33
Table 4.13:	Rules for detailing of RC shear walls according to KTP-N.2-89	34
Table 6.1:	List of collected information	55

Figures

Figure 1.1:	The EEFIT team in front of the damaged tower in the Castle of Krujë. From left to right: Emiljano Zhuleku, Anton Andonov, Federica Greco, Viviana Novelli, Fabio Freddi (back row), Roberto Gentile, Stoyan Andreev and Enes Veliu	6
Figure 1.2:	Visited locations during EEFIT Albania mission 2019	7
Figure 2.1:		8

Figure 2.2: Active faults in Albania with expected maximum magnitudes	9
Figure 2.3: Significant earthquakes in Albania 1000-2006 and active faults	10
Figure 2.4: Reported intensities and isoseismals for the 1979 Montenegro earthquake	11
Figure 2.5: Albanian earthquake sequence of 2019	12
Figure 2.6: Estimated GM amplification based on V_{s30}	13
Figure 2.7: Liquefaction along Durrës beach	14
Figure 2.8: Surface manifestation of liquefaction along Durrës beach	14
Figure 2.9: a) Tilt and b) subsidence of multi-storey building due to soil reconsolidation	15
Figure 2.10: Geological map of Durrës and the beach area	16
Figure 3.1: Distribution of the population among the regions of Albania	18
Figure 3.2: Distribution of housing buildings by main construction material	19
Figure 3.3: Number of buildings by number of stories according to INSTAT 2011 Census	20
Figure 3.4: Representative typologies of Albanian multistory residential building stock	21
Figure 3.5: Number of buildings by the period of construction according to INSTAT 2011 Census	22
Figure 4.1: Seismic hazard map in KTP-2-78, in MSK-64 macroseismic intensity scale	24
Figure 4.2: Lumped weights on an idealized shear type building (adapted from KTP 2-78)	25
Figure 4.3: Seismic hazard map in KTP-N2-89, in MSK-64 macroseismic intensity scale	28
Figure 4.4: Column layout according to KTP-N2-89	32
Figure 4.5: Beam layout according to KTP-N2-89	33
Figure 4.6: Shear wall layout according to KTP-N2-89	34
Figure 4.7: Reference PGA map of Albania for 475 years return period	35
Figure 5.1: EMS-98 intensity for the 26th November earthquake	37
Figure 5.2: ShakeMap intensity for the 26th November earthquake	38
Figure 5.3: Strong motions recorded in Durrës during the 26th November earthquake	39
Figure 5.4: Response spectra of Durrës records vs KTP-N2-89 elastic demand	39
Figure 5.5: Strong motions recorded in Tirana during the 26th November earthquake	40
Figure 5.6: Response spectra of Tirana records vs KTP-N2-89 elastic demand	40
Figure 5.7: Estimate of the breakdown of the economic damage in absolute values (in million USD). The yellow bars highlight the damage severity in each zone relative to the damage in the epicentral zone for the sector	41
Figure 5.8: Estimate of the breakdown of the relative economic damages as percentage of total exposure value for the sector	41
Figure 5.9: Damage and losses per sector and sub-sector	42
Figure 5.10: Damage and losses disaggregation by municipality	43
Figure 5.11 Severe material deprivation in the affected areas	46
Figure 5.12: Four-storey RC building in Durrës that caused 8 fatalities	49
Figure 5.13: Six-storey RC building in Durrës, built in 1996 that caused 7 fatalities	49
Figure 5.14: Five-storey RC building in Durrës, a hotel dedicated to the employees of the Internal Ministry, in Durrës that caused 1 fatality	50
Figure 5.15: Six-storey hotel in Durrës, that caused 2 fatalities, at least the first five stories are RC, that caused 2 casualties	50
Figure 5.16: Five-storey RC hotel in Durrës that caused 2 fatalities	51
Figure 5.17: Eight-storey RC hotel in Durrës that caused 1 fatality	51

Figure 5.18: Six-storey RC building that caused 2 fatalities	51
Figure 5.19: Two five-storey calcium-silicate masonry buildings in Kodër-Thumanë that caused 24 fatalities	52
Figure 6.1: Damage level classification based on EMS-98	56
Figure 6.2: ASCE41-17 performance levels	57
Figure 6.3: Example of summarised information collected during the mission: access; location; construction typology; and use of the inspected building	59
Figure 6.4: Field mission database summary filtered by construction typology: number of stories; year of construction; performance level (ASCE41); Damage Grade (EMS-98)	60
Figure 6.5: Inspected buildings and assigned EMS-98 damage grades: Durrës city	61
Figure 6.6: Inspected buildings and assigned EMS-98 damage grades: Durrës beach area	62
Figure 6.7: Inspected buildings and assigned EMS-98 damage grades: Laç	63
Figure 6.8: Inspected buildings and assigned EMS-98 damage grades: Lezhë	64
Figure 6.9: Inspected buildings and assigned EMS-98 damage grades: Bubq, Thumanë, Krujë castle and Prezhë castle	65
Figure 7.1: a) Standard template of a 3-storey URM building Original plan can be found at [7.1], b) typical 3-storey URM building in Thumanë, Albania	66
Figure 7.2: a) Standard template of a 5-storey URM building. Original plan can be found at [7.4], b) typical 5-storey URM building in Thumanë, Albania	67
Figure 7.3: Typical bricks for URM buildings. Solid clay bricks with a) silicate mortar; b) cement mortar; c) silicate bricks with silicate mortar	67
Figure 7.4: Typical 5-storey URM buildings in Durrës	68
Figure 7.5: Irregularities in elevations due to unauthorised interventions on URM buildings in Durrës	68
Figure 7.6: a) Collapsed 5-storey URM building in Thumanë; b) view from the air of the collapsed building in Thumanë; c) destruction in the town of Thumanë, one of the worst affected areas	69
Figure 7.7: a) 5-storey pre-1990 URM buildings made of silicate bricks and hollow core precast concrete slabs, inspected in Lezhë (red tagged by local engineers), b) typical light shear cracks observed on internal bearing walls	70
Figure 7.8: a) 5-storey pre-1990 URM buildings made of silicate bricks and hollow core precast concrete slabs, inspected in Lezhë (red tagged by local engineers), b) pounding damage between the URM building and RC building, c) gap opening, and d) detachment of the staircase	70
Figure 7.9: Main structural characteristics of LPBs in Albania: a) panel types; b) 3D view of LPB construction sequence; c) panels before assembly; based on [7.7]	71
Figure 7.10: Typical floor plans and configurations of large-panel buildings in Albania [7.7]	72
Figure 7.11: In-plane action of prefabricated wall, a) shear forces and b) tensile and compressive forces [7.20]	73
Figure 7.12: Behaviour of a large panel wall under lateral load – monolithic behaviour (a), vertical slip between panels (b) and horizontal slip (c) [7.21]	73
Figure 7.13: Neighbourhood with LPBs in Laç (Module 1, two sections)	74
Figure 7.14: LPBs in Laç (Module 1, two sections): Vertical cracks formed in the interface between wall panels	74
Figure 7.15: Neighbourhood with LPBs in Durrës (Module 2 with one, two & three sections)	75

Figure 7.16: LPBs in Durrës (Module 2 with one, two & three sections): horizontal cracks formed in the interface between the wall panel and the floor panels	75
Figure 7.17: Example of typical RC multi-storey buildings. a) Typical 2000s building compliant with KTP-N.2-89; b) Typical post-2010 building compliant with KTP-N.2-89 with integration based on the Eurocode 8	76
Figure 7.18: a) Comparison of the elastic and design spectra for one representative site according to the KTP-N.2-89 [7.2] and Eurocode 8 [7.1]; b) belt beam for infill panels in typical post-2010 multi-storey RC buildings	77
Figure 7.19: Typical 2000s multi-storey RC building compliant with KTP-N.2-89: a) east façade; b) south façade; c) indicative plan view	78
Figure 7.20: Typical 2000s multi-storey RC building compliant with KTP-N.2-89: a) cracks in the plaster and identification of beams and columns; b) dimension of the hollow bricks for the infill panels	79
Figure 7.21: Typical 2000s multi-storey RC building compliant with KTP-N.2-89: a) collapse of the infill panel; b) detachment of the infill panel and formation of horizontal cracks	79
Figure 7.22: Typical 2000s multi-storey RC building compliant with KTP-N.2-89: damage layout on the eastern façade of the building	80
Figure 7.23: Typical 2000s multi-storey RC building compliant with KTP-N.2-89: damage layout on the eastern façade of the building, closeup	80
Figure 7.24: Typical post-2010 multi-storey RC building compliant with KTP-N.2-89 with integrated aspects of Eurocode 8: a) north-east facade; b) south-east side; c) indicative plan view	82
Figure 7.25: Typical post-2010 multi-storey RC building compliant with KTP-N.2-89 with integrated aspects of Eurocode 8: a) exterior damage related to the interaction with the stairs; b) damage on the landing of the stairs	83
Figure 7.26: Typical post-2010 multi-storey RC building compliant with KTP-N.2-89 with integrated aspects of Eurocode 8. Unconfined internal infill showing damage at the a) 2 nd storey; b) 5 th storey	83
Figure 7.27: Typical post-2010 multi-storey RC building compliant with KTP-N.2-89 with integrated aspects of Eurocode 8. a) exterior damage due to torsion; b) failure of unconfined infill	84
Figure 7.28: Typical post-2010 multi-storey RC building compliant with KTP-N.2-89 with integrated aspects of Eurocode 8. Effects of the belt beams in confined and unconfined infills.	84
Figure 7.29: Case with structural damage showing shear and axial failure in a) external column; b) internal column	85
Figure 7.30: Collapsed single-family rural houses in Bubq. URM building with hollow concrete blocks and RC slab at the 1 st level and hollow brick waffle concrete slab at the 2 nd level	86
Figure 7.31: Collapsed single family rural house in Bubq: a) severely damaged side façade b) internal view of the failed portico, c) and d) details of the poor reinforced columns of the portico at the join connections.	87
Figure 7.32: Extensive damage in single-family rural house in Bubq	87
Figure 7.33: Location of the visited castles. Tirana shown for reference	88
Figure 7.34: Visible repairs of the walls and towers of Durrës (a) Venetian tower and (b) gate tower	88
Figure 7.35: View of the gate tower before (a) and after (b) the November earthquake	89

Figure 7.36: View of the surfaces of rupture of the gate tower	90
Figure 7.37: Close view of the collapsed masonry in Durres	91
Figure 7.38: View of the Krujë Castle from the air	92
Figure 7.39: View of the anchors present on the hill's side near the clock tower	92
Figure 7.40: View of the Krujë clock tower before and after the earthquake	93
Figure 7.41: Tekke of Dollma before the earthquake	94
Figure 7.42: View of the Tekke of Dollma a) before and b) after the November earthquake	95
Figure 7.43: View of the cracking of Tekke of Dollma dome	95
Figure 7.44: Exaggerated schematic illustration of cracking of a dome due to increase of span [7.17]	96
Figure 7.45: View of Prezë Castle from a drawing on the wall of the restaurant of the castle	97
Figure 7.46: Damage suffered by the Prezë castle clock tower at different times [7.18]	97
Figure 7.47: Photos showing the intervention on Prezë clock tower in summer 2019	98
Figure 7.48: View of the Prezë clock tower: a) before and b) after the 2019 earthquake	99
Figure 7.49: Damage observed on the south side of the Prezë clock tower: a) overview and b) closeup	99
Figure 7.50: View of the Prezë north tower and alteration to the original configuration: a) new reinforced concrete slab, b) new construction adjacent to the side of the tower	100
Figure 7.51: View of the damage to the Prezë clock tower	100
Figure 7.52: Collapsed sections of the fortified walls: (a) Krujë castle, (b) Prezë castle	101

Acronyms

ANSS ComCat	Comprehensive Earthquake Catalogue
CAD	current account deficit
CP	Civil Protection
DRR	Disaster Risk Reduction
EDSF	European Database of Seismogenic Faults
EEFIT	The Earthquake Engineering Field Investigation Team
EMEC	European-Mediterranean Earthquake Catalogue
EPSRC	Engineering and Physical Sciences Research Council
EU	European Union
EUCPM	European Civil Protection Mechanism
GDP	Gross domestic product
GPS	Global Positioning System
GRADE	Global Rapid post-disaster Damage Estimation
IGEWE	Albanian Institute of Geophysics, Water and Energy
INSTAT	Albanian Institute of Statistics
PDNA	Post-Disaster Needs Assessment
PGA	Peak ground acceleration
RC	Reinforced concrete
SARAIID	Search and Rescue Charity
SHDE	Survey of Household Damages due to Earthquake
TEV	Total Exposure Value
UCL	University College London
UN	United Nations
UNDAC	UN Disaster Assessment and Coordination
UNDP	United Nations Development Program
URM	Regarding unreinforced masonry
USAR	Urban Search and Rescue (USAR)
WB	World Bank

Acknowledgment

The EEFIT Albania mission team would like to express our sincere gratitude to the following individuals and organisations for their support prior to, during and following this mission, without whom we would not have been able to carry out the field trip and research effectively:

- Markel Baballëku –Vice Dean of Faculty of Civil Engineering, Polytechnic University of Tirana.
- Gerald Dautaj
- Isak Idrizi –Mother Teresa University, Skopje, Macedonia.
- Filip Kirazov, Search and Rescue Assistance in Disasters (SARAID)
- Joshua Macabuag, Search and Rescue Assistance in Disasters (SARAID)
- Bledar Metalla
- Antonios Pomonis, The World Bank
- Olsi Plasa, Director of the Tirana Culture Heritage Directorate
- Valentina Putrino, University College London (UCL)
- Elenita Roshi, Polytechnic University of Tirana
- Mark Scorer, Search and Rescue Assistance in Disasters (SARAID)
- Anastasios Sextos, University of Bristol
- Klodian Zaimi - Head of Department of Water Economy and Renewable Energy. Polytechnic University of Tirana
- Anxhela Zaza – Colasanti Limited, Albania
- Emiljano Zhuleku, Mott MacDonald Albania

The team thanks for the financial support of the following organisations for funding the participation of team members:

- Engineering and Physical Sciences Research Council (EPSRC) for funding Dr. Fabio Freddi and Dr. Roberto Gentile
- University of Bristol for funding Dr. Viviana Novelli
- ARUP for funding Federica Greco
- Mott MacDonald for funding Mr Anton Andonov and Mr Stoyan Andreev and covering partially the costs of Mr Enes Veliu

EEFIT would like to acknowledge the on-going support of corporate sponsors: Sellafeld Ltd, Guy Carpenter, Atkins, AIR Worldwide Ltd, Willis Re, AECOM, Arup and Mott MacDonald

Executive summary

The 26th of November earthquake in northwest Albania affected at least 10 of the country's 61 municipalities, including the two most populous, urbanized and developed cities Tirana and Durrës. This was the strongest earthquake in Albania for the last 40 years and the worldwide deadliest earthquake for 2019. The Earthquake Engineering Field Investigation Team (EEFIT) sent a team to the affected region during the immediate aftermath of the event (13th to 18th December). The mission objectives were to observe the characteristic damage patterns in the main structural typologies of the Albanian residential building stock and to assess possible links between the observed damage patterns with code and construction practice deficiencies. This leads to the following structure of the report:

Section 1 provides general introduction of the mission team composition, the mission objectives and the mission itinerary.

Section 2 provides information about the seismotectonic and geotechnical aspects.

Section 3 provides information about the main structural typologies and key statistics related to the Albanian building stock.

Section 4 provides a summary of the last two revisions of the Albanian seismic design code.

Section 5 provides information regarding the available strong motion records and describes the official damage and loss statistics and the macro- and socio-economic consequences of the event.

Section 6 explains the damage assessment forms used for this mission and provides statistical data about the inspected buildings.

Section 7 describes several case studies to illustrate the characteristic damage patterns observed in the main structural typologies of the Albanian building stock.

Section 8 provides final remarks and lessons learned from the mission

The EEFIT mission team members contributed to developing of this report as follows:

- Mr Anton Andonov – executive summary, chapter 1, chapter 5, section 7.2, chapter 8
- Mr Stoyan Andreev –section 2, report formatting, maps compilation
- Dr. Fabio Freddi – section 7.3, editor of chapter 7
- Ms Federica Greco – chapter 6, section 7.5
- Dr. Roberto Gentile – chapter 6, section 7.3
- Dr. Viviana Novelli – section 7.1, section 7.4,
- Mr Enes Veliu – chapter 3, chapter 4, section 5.6

1 Introduction

On 26th November 2019 at 03:54 CET, an earthquake with moment magnitude M_w 6.4 and focal depth of 20 km struck northwest Albania. This was the strongest earthquake in Albania for the last 40 years and caused extensive damage to at least 10 of the country's 61 municipalities, including the two most populous, urbanized and developed cities Tirana and Durrës. The earthquake caused 51 deaths, from which 47 were caused by the collapses of 9 buildings. Information collected from media sources and through personal communication with people on the ground suggested that the earthquake caused sufficient damage, in particular to the residential sector, to justify a reconnaissance mission.

1.1 The EEFIT Mission

The day immediately after the earthquake, the EEFIT Management Committee discussed the potential deployment of a field mission to observe the damage in Albania. A consensus within the committee to deploy a mission two-three weeks after the earthquake was reached the same day, targeting a mission team of 5-6 members with prior experience in post-earthquake reconnaissance that could split in two teams/vehicles and operate autonomously.

Based on the initial information from media sources, and from personal contacts already on the field, it was identified that the earthquake induced damage was concentrated mainly in the housing sector. Moreover, damage was reported to both pre-1990 buildings built to old seismic design codes and to new post-2010 tall RC residential buildings. All reported collapses were in residential buildings too and most of the collapsed buildings were RC frame structure built in the 1990s during a period with inefficient law enforcement. Therefore, it was decided to limit the mission scope to the housing sector and having the following main objectives:

- To carry out observations on the characteristic damage patterns in the main structural typologies in the Albanian residential building stock;
- The review the evolution of the Albanian seismic code and construction practice and assess possible links between the observed damage patterns with code and construction practice deficiencies.

Call for Expression of Interest for the EEFIT mission was sent to EEFIT members on the 29th of November 2019 with a deadline to submit applications by the 05th of December and targeting the mission between the 13th and 18th of December. The following day, 06th of December 2019, the Management Committee reviewed the 21 applications received, and selected seven individuals to be contacted asking to confirm their availability. The selection strategy aimed at identifying a balanced team with approximately 50/50 share of academia and industry participants and expertise in masonry and reinforced concrete (RC) building structures. Knowledge of Albanian and Italian languages was considered advantageous in the selection process. All individuals confirmed their participation which led to the definition of the final team composed by (in alphabetic order):

- Mr Anton Andonov – Team Leader (Mott MacDonald): structural engineer with 15 years of experience in earthquake engineering covering seismic analysis, assessment and design of regular and critical facilities, and probabilistic seismic risk analysis.
- Mr Stoyan Andreev (Mott MacDonald) – Senior engineer with nine years of experience in structural and geotechnical earthquake engineering, advanced seismic analysis and design,

seismic hazard and risk analysis and safety assessment for civil and critical infrastructure including nuclear power plants, large water-retaining and tailings dams.

- Dr Fabio Freddi (University College London) – Lecturer in Structural Design with expertise in the areas of earthquake engineering focusing on the design, assessment and retrofitting of steel and reinforced concrete structures, use of seismic devices, probabilistic tools, numerical simulations and large-scale structural tests.
- Ms Federica Greco (ARUP) – Senior engineer at Arup, working in the Advance Technology and Research team, with experience on seismic assessment of existing buildings and cultural heritage.
- Dr Roberto Gentile (University College London) – Marie Curie Senior Research Fellow at the University College London. His research expertise involves seismic risk and vulnerability analysis, particularly for reinforced concrete structures. He completed his PhD in Earthquake Engineering in 2018 at the Polytechnic University of Bari, joint with the University of Canterbury, New Zealand.
- Dr Viviana Novelli (Cardiff University) – Lecturer in Civil Engineering with experience in seismic vulnerability assessment of unreinforced masonry buildings and cultural heritage.
- Mr Enes Veliu (IUSS Pavia) – PhD candidate at the University School for Advanced Studies IUSS Pavia in Italy, where he conducts research in the field of Seismic Risk Assessment and Loss Estimation. Before joining IUSS Pavia he held a position as an Assistant Professor at the Technical University of Tirana, Albania.

The mission team was supported through the whole duration of the mission from Mr Emiljano Zhuleku, Country Manager for Mott MacDonald Albania.

Figure 1.1: The EEFIT team in front of the damaged tower in the Castle of Krujë. From left to right: Emiljano Zhuleku, Anton Andonov, Federica Greco, Viviana Novelli, Fabio Freddi (back row), Roberto Gentile, Stoyan Andreev and Enes Veliu



1.2 Mission itinerary

All team members arrived in Albania on Friday, 13th December and met in a hotel in downtown Tirana which was used as a base during the entire mission. Initial review of the available information highlighted Bubq, Laç and Lezhë as locations of interest in addition to the city of Durrës, Durrës Beach and the village of Thumanë which were extensively covered in the media since almost all casualties were from these two locations. Initial contacts established with Elenita Roshi from the Polytechnic University of Tirana, flagged a concentration of structural damages in

two historic sites, namely Krujë castle and Prezë castle, which were also included in the “to-do list”. The travel itinerary for the mission was as follows (see Figure 1.2¹):

- Friday 13th December – the EEFIT team arrived in Albania, met at the airport, collected the cars and travelled to the hotel in downtown Tirana.
- Saturday 14th December – both cars/groups travelled to Lezhë and then Laç and Thumanë on the way back, and visiting several residential buildings of different construction type and level of damage, as well one primary school in Lezhë and one hospital in Laç.
- Sunday 15th December – the team travelled to the city of Durrës, then split in two groups and walked within the area between the Durrës port and the stadium, where damage clusters were observed.
- Monday 16th December – the team travelled to Bubq and then to the castles in Krujë and in Prezë.
- Tuesday 17th December – the team travelled to the area called “The Beach” in Durrës and then split in two groups and walked through the area which was also known to have damage clusters.
- Wednesday 18th December – EEFIT team departure from Albania.

Figure 1.2: Visited locations during EEFIT Albania mission 2019

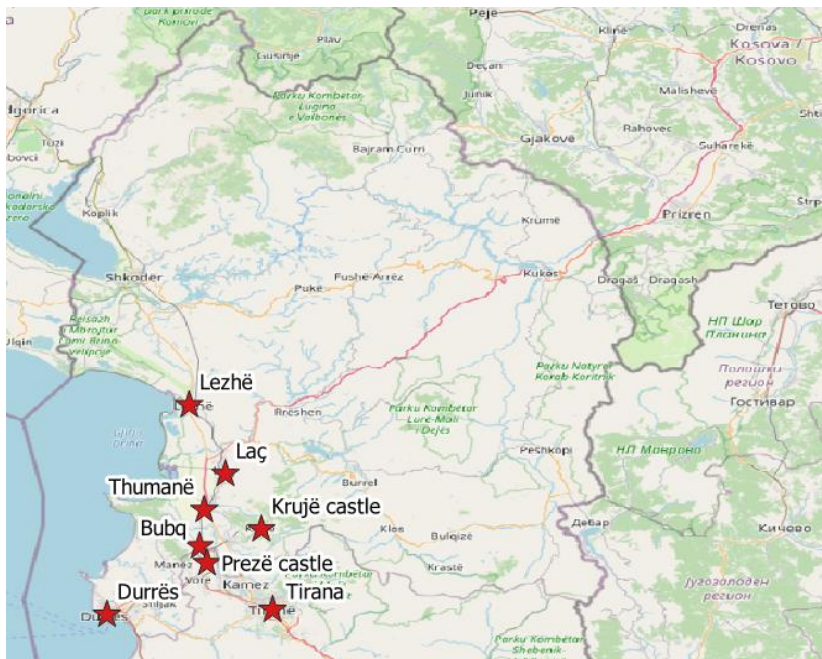

Source: OpenStreetMap, map developed on QGIS v.3.12

¹ All maps in the report are developed by the field team using the open-source GIS software QGIS if not referred otherwise

2 Seismotectonic and geotechnical aspects

The 26th of November 2019, moment magnitude M_w 6.4 Albania earthquake occurred as the result of thrust faulting near the convergent boundary of the Africa and Eurasia plates. Focal mechanism solutions indicate reverse slip on a shallow or steeply dipping fault. Northwest-Southeast striking reverse faulting is consistent with the tectonics of the region. At the location of this event, the Africa plate converges with the Eurasia plate at fast rates, determining continuous regular occurrence of strong earthquakes. The official USGS description of the tectonic settings and regional seismicity was used in this section.

2.1 Tectonic setting of the region

Albania is located in the convergent boundary region between Africa and Eurasia. This region has complex tectonic setting and is affected by the motions of numerous microplates and regional-scale structures, such as the Adria plate (see Figure 2.1). The convergence of the Adria and Moesia plates across the Southern Dinarides is the direct cause of the seismic activity in Albania [2.1]. The cause of the earthquake on 26th November 2019 and most contemporary events in western Albania is reverse faulting on the eastern shores of the Adriatic Sea. Such focal mechanism is consistent with the closing of that sea and shortening across the mountain belts stretching from Croatia to Greece (Figure 2.1).

Figure 2.1: Tectonic map of the Western Mediterranean with post-20Ma motions of the Adria plate

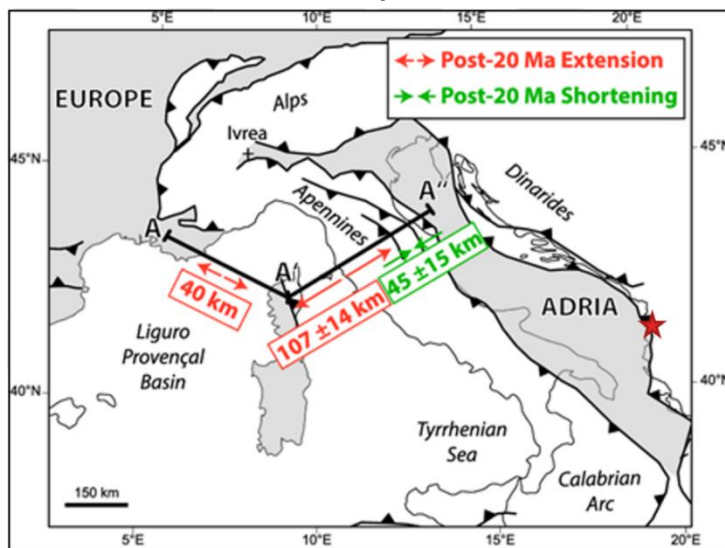

Source: Le Breton et al. (2017) [2.1], November 2019 earthquake epicentre highlighted with red star

Due to the complex tectonic setting of the Southern Dinarides and continuous convergence along the plate boundaries, a large number of geological faults in Albania are currently active and can produce strong earthquakes with magnitudes above 6.5, see Figure 2.2. Based on the estimates made for compiling the European Database of Seismogenic Faults (EDSF) [2.3] the faults slip with rates between 0.5 and 1.0 mm/yr.

Figure 2.2: Active faults in Albania with expected maximum magnitudes

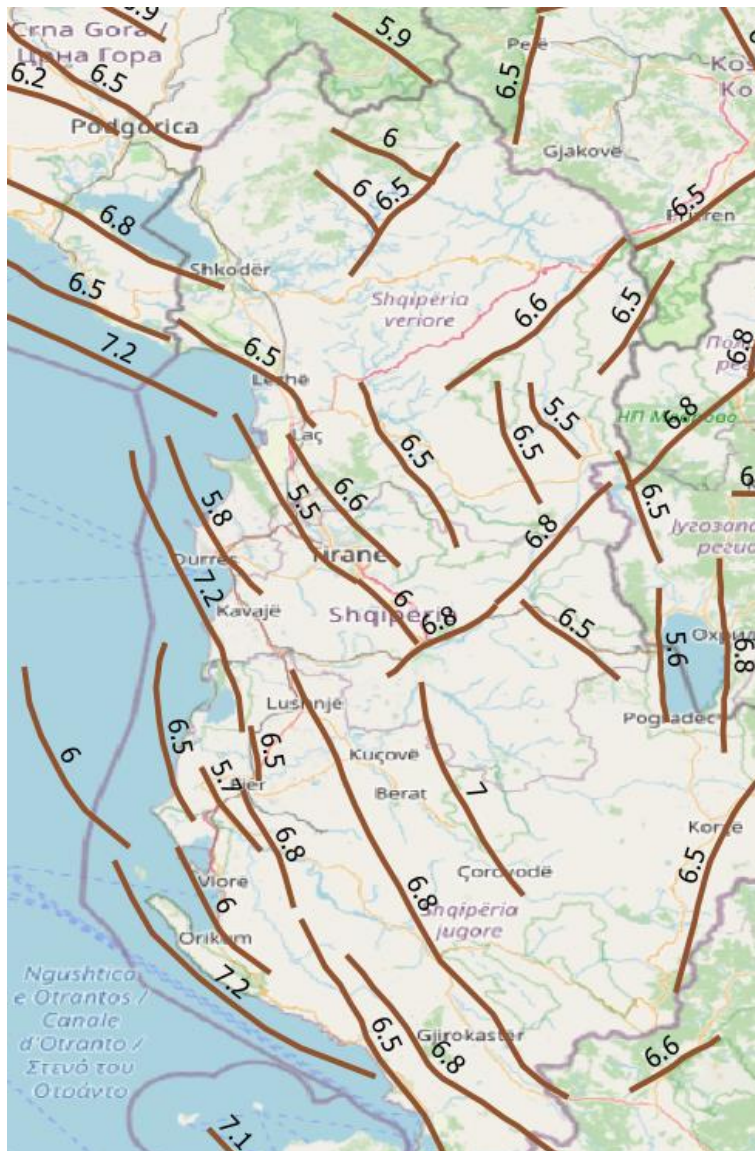

Source: European Database of Seismogenic Faults [2.3]

2.2 Historical seismicity in the region

A large number of moderate-to-strong earthquakes ($M_w > 4.5$) have been observed in the Albanian territory during historical times, as seen from the European-Mediterranean Earthquake Catalogue (EMEC) [2.2]. The known epicentres of Albanian earthquakes are in agreement with the location of active faults as illustrated in Figure 2.3.

Figure 2.3: Significant earthquakes in Albania 1000-2006 and active faults

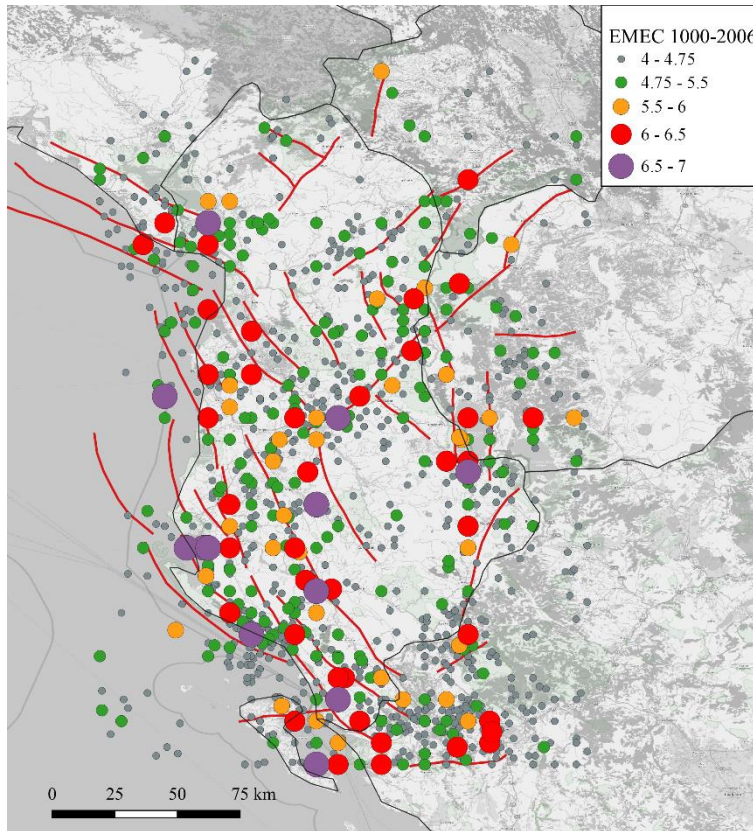

Source: EMEC catalogue [2.2], EDSF fault traces [2.3], base map from OSM

The most recent strong earthquake affecting Albania was the M_w 6.9 Montenegro earthquake in 1979 with epicentre close to the southernmost border region between Albania and Montenegro. This earthquake was felt with MSK-64 macroseismic intensities between VI in Central Albania and VII-VIII in the region of Shkodër. The distribution of reported intensities and the reconstructed isoseismals for this event reported by Papazachos *et al.* [2.5] are shown in Figure 2.4.

Figure 2.4: Reported intensities and isoseismals for the 1979 Montenegro earthquake

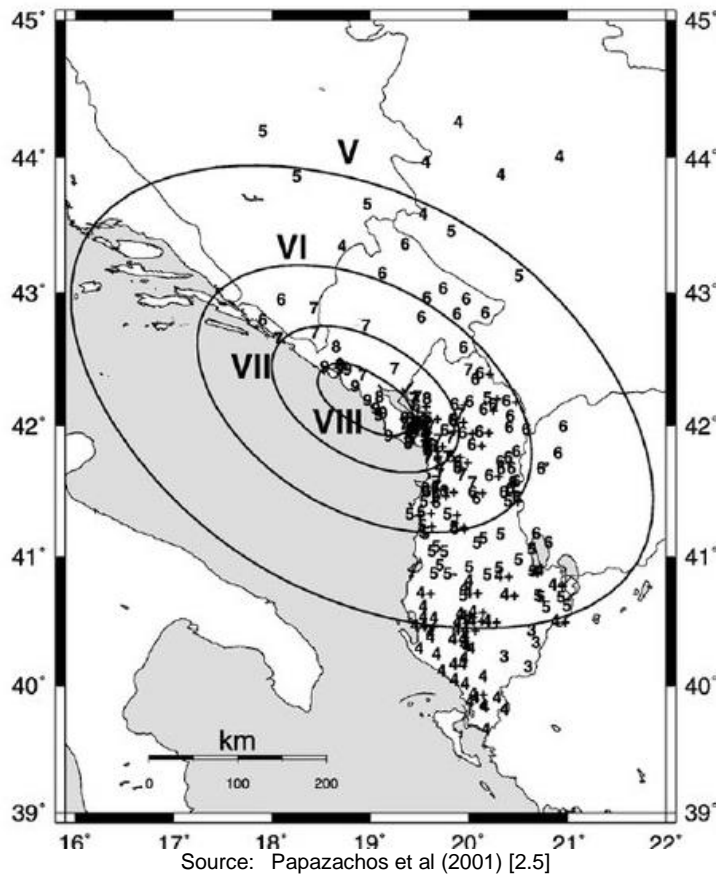

2.3 The 2019 earthquake sequence in central Albania

The 2019 earthquake series in central Albania started with a strong M_w 5.6 event at 15:15 CET on Saturday 21st September. The epicentre of the earthquake was estimated to be on the outskirts of Durrës. Despite the proximity to the city and being the strongest earthquake in Albania in the last 40 years, the event had relatively small consequences with no fatalities, ~110 injured people and ~120 damaged buildings without structural failures.

On 26th November at 03:54 CET central and north-west Albania was struck by the main shock of the sequence – M_w 6.4 event with epicentre 16 kilometres west-southwest of the town of Mamurras in Kurbin municipality. The maximum felt intensity near the epicentre was VIII (Severe) on the Modified Mercalli Intensity scale. After three strong aftershocks with M_w 5.1 to M_w 5.4 on the same day, the increased seismic activity continued for a few months with regular M_w 4 earthquakes until at least the beginning of January 2020. The estimated epicentres and magnitudes of the felt earthquakes ($M_w > 3.5$) in the sequence based on ANSS Comprehensive earthquake catalogue [2.4] are shown in Figure 2.5.

The ANSS ComCat moment tensor solution for the main shock gives strike angle 338° , dip angle 27° towards east and rake angle 91% consistent with the expected active thrust tectonics in central Albania. Recently available GPS measurements [2.6] confirm the preliminary solution.

Figure 2.5: Albanian earthquake sequence of 2019

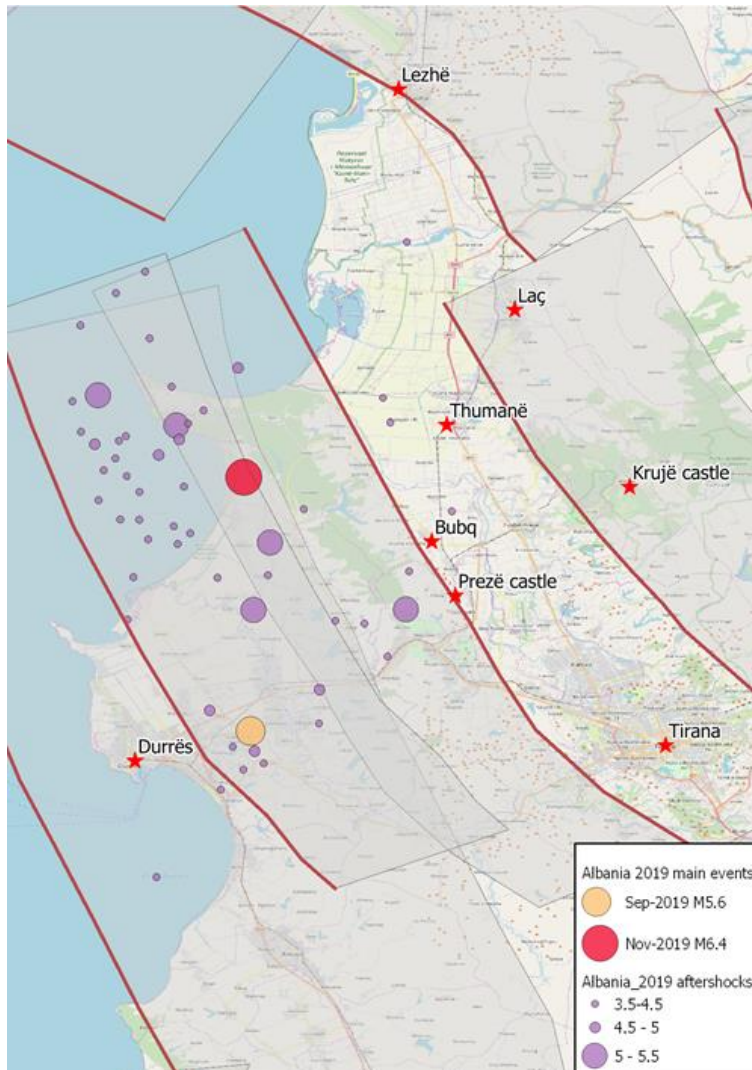

Source: ANSS ComCat [2.4], EDSF fault traces [2.3], base map from OSM

2.4 Geotechnical conditions and geohazards

The strong ground motion from the M_w 6.4 earthquake affected areas with different soil conditions – from soft and potentially liquefiable Holocene deposits with high water table (EN classes D and S_2) in the coastal regions, through deep alluvium stiff soil deposits (EN class C) in the plane around Tirana to rock outcrops (EN class A) in the mountainous areas. The varying soil stiffness and stratification determine very different local site response across the affected area – from no amplification to high amplification of the ground motions with respect to the underlying bedrock. Although precise assessment of the ground motion amplification during the November 2019 earthquake is impossible due to insufficient data, approximate estimations were done. One such estimation was done by the team of Temblor [2.7], based on their in-house STAMP (SiTe AMPlification) model with V_{s30} as input, see Figure 2.6. The estimation showed at least moderate amplification of the ground motion for most of central Albania and strong amplification in Durrës,

Lezhë, and Thumanë areas. The predicted high amplifications agree very well with the observed increased levels of damage in these areas.

Figure 2.6: Estimated GM amplification based on V_{s30}

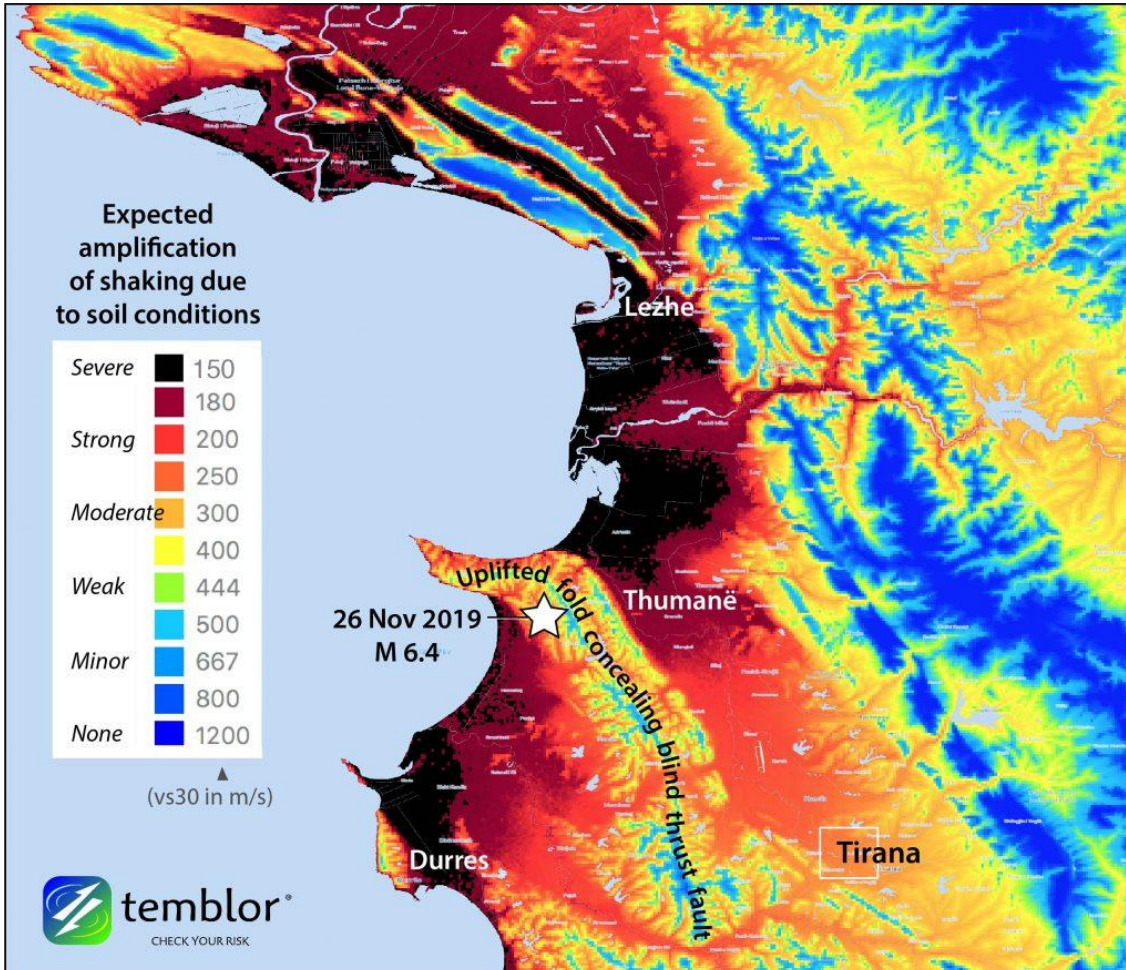

Source: Stein and Sevilgen 2019 [2.7]

In addition to the primary seismic hazard due to strong ground motion, secondary earthquake-induced geohazards are also significant in the affected area of Central Albania:

- Sand boils and ground cracking due to liquefaction;
- Lateral spreading in coastal areas due to liquefaction;
- Soil subsidence due to reconsolidation after liquefaction;
- Earthquake induced slope failure and landslide;
- Rockfalls.

Except for soil subsidence and near surface liquefaction in Durrës beach area (south of the city centre), no widespread manifestations of the potential geohazards were observed and no damage related to them was reported. It is very likely that some pre-existing landslides and rockfalls in precarious conditions, such as the one beneath the Krujë castle (see also Section 7.5.2) were activated, but movement due the earthquake cannot be estimated without precise geodetical measurements.

2.5 Observed ground failures

The initial reports after earthquake hinted at manifested liquefaction at different locations along the Adriatic coast of Central Albania. The observations made by engineers working in the field in the affected areas generally disproved the initial reports and confined the observed liquefaction only to the Durrës beach area. However, soil liquefaction phenomena and ground failure in general are likely key contributors to the significant damage and collapse of three adjacent hotels in the beach area, see Figure 2.7, obtained from the report of Lekkas *et al.* from NKU Athens [2.8]. Although not widespread, surface manifested liquefaction, e.g., sand ejecta, was observed in several locations across the Durrës beach area (Figure 2.8).

Figure 2.7: Liquefaction along Durrës beach



Source: Lekkas et al. (2019), National and Kapodestrian University of Athens [2.8]

Figure 2.8: Surface manifestation of liquefaction along Durrës beach



Source: Lekkas et al. (2019), National and Kapodestrian University of Athens [2.8]

Due to the scarcity of reported damage to residential buildings from earthquake-induced geohazards, the EEFIT team did not focus on identifying and investigating specific locations affected by liquefaction. However, the team came across a few such locations, mostly along the coast south of the city centre. In these locations post-2000 multi-storey buildings sunk relatively to the surrounding streets or alleys. These buildings were supported on common rafts and usually had basements. The subsidence is explained with reconsolidation of the soft soils accompanying the dissipation of pore water pressure accumulated during the earthquake. In the visited basements of three multi-storey buildings the ground water levels after the earthquake were noticeably higher than usual per occupants' testimony. The 2nd basement level of one multi-storey building constructed around 2010 was reported to be flooded and inaccessible.

The most significant effect of soil reconsolidation after the earthquake was observed in a multi-storey RC building in downtown Durrës (stadium area) with one basement level and common raft foundation. The building was notably tilted about the shorter side and had sunk of about 8-10 cm (Figure 2.9). Due to these problems, the building was red tagged by local engineers and was evacuated. The occupants reported minor subsidence problems during normal operation before the earthquake. No changes of the building stability due to aftershocks were reported.

Figure 2.9: a) Tilt and b) subsidence of multi-storey building due to soil reconsolidation



The observed liquefaction and ground subsidence cases were in the areas of the city covered by either soft Holocene marshy deposits – clays, silts, sands and peats or Holocene marine sands as shown in the geological map of Durrës – Figure 2.10 after Shkëlqim et al [2.8].

Figure 2.10: Geological map of Durrës and the beach area

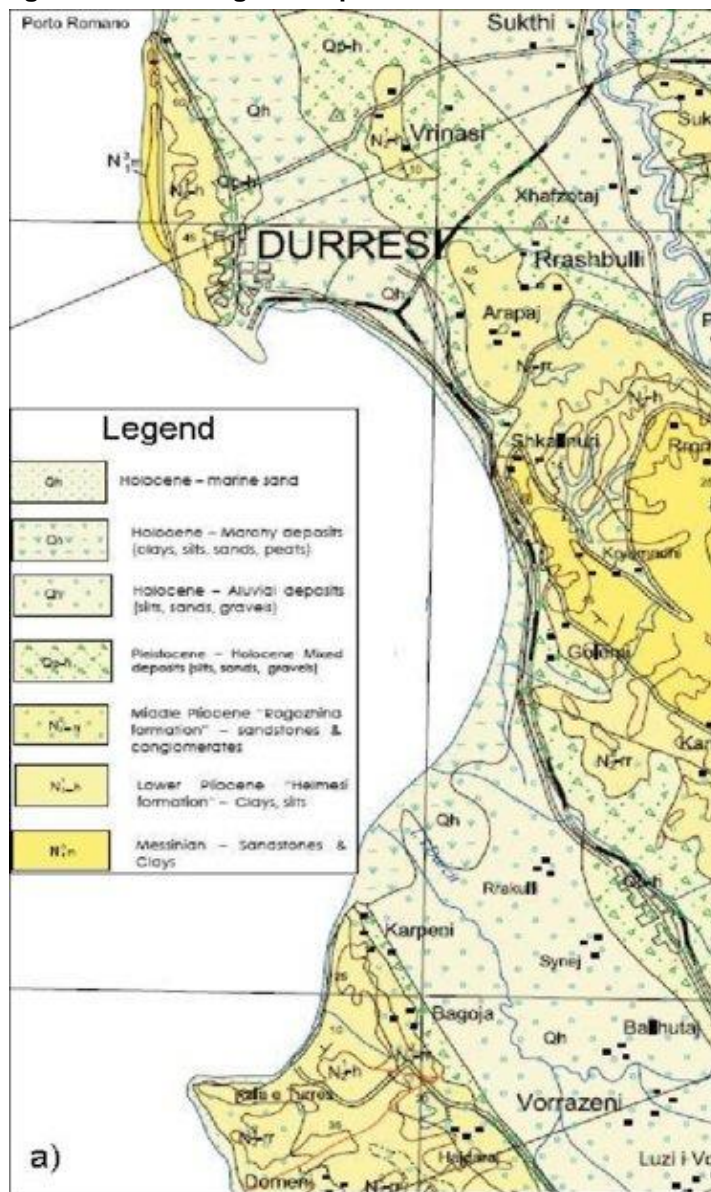

Source: Shkëlqim et al (2010) [2.8]

2.6 References for chapter 2

- [2.1] E. Le Breton, M. R. Handy, G. Molli & K. Ustaszewski, 2017, Post-20 Ma motion of the Adriatic plate – new constraints from surrounding orogens and implications for crust-mantle decoupling: Post-20 Ma motion of the Adriatic plate, *Tectonics*, 36(12), pp 3135-3154
- [2.2] G. Grünthal, & R. Wahlström, 2012, The European-Mediterranean earthquake catalogue (EMEC) for the last millennium. *Journal of Seismology* 16(3): 535-570
- [2.3] The European Database of Seismogenic Faults at <http://diss.rm.ingv.it/share-edsf/>, accessed January 2020

- [2.4] ANSS Comprehensive Earthquake Catalogue (ComCat), <https://earthquake.usgs.gov/data/comcat/>, accessed January 2020
- [2.5] Papazachos, B., Savvaidis, A., Papazachos, C., Papaioannou, Ch., Kiratzi, A., Muco, B., Kociu, S., Sulstarova, E., 2001. Atlas of isoseismal maps for shallow earthquakes in Albania and surrounding area, Publ. Dep. Geophys. 10, 57
- [2.6] A. Ganas, V. Tsironi, F. Cannavo, P. Briole, P. Elias, S. Valkaniotis, I. Koukouvelas, E. Sokos, 2020, Co-seismic deformation and preliminary fault model of the M6.4 Durrës (Albania) Nov. 26, 2019 earthquake, based on space geodesy observations, presentation at https://presentations.copernicus.org/EGU2020/EGU2020-8478_presentation.pdf, accessed May 2020
- [2.7] R. Stein & V. Sevilgen, 2019, “Albania earthquake strikes highest-hazard zone in the Balkans, devastating nearby towns”, posted at <https://temblor.net/earthquake-insights/albania-earthquake-strikes-highest-hazard-zone-in-the-balkans-devastating-nearby-towns-10153/>, accessed Dec-2019
- [2.8] E. Lekkas, S. Mavroulis, D. Papa, P. Carydis, 2019, “The November 26, 2019 Mw 6.4 Durrës (Albania) earthquake”, Newsletter of Environmental, Disaster, and Crises Management Strategies, issue 15, National and Kapodistrian University of Athens
- [2.9] D. Shkëlqim, D. Çerçis, A. Sinojmeri, S. Nazaj, 2010, Landslides susceptibility in central part of Albanian coast, Proceedings of Littoral 2010 – Adapting to Global Change at the Coast: Leadership, Innovation, and Investment, London

3 Description of the Albanian building stock

The residential building stock of Albania comprises 598,267 buildings that accommodate 1,012,400 dwellings, according to the 2011 census [3.2]. The ratio of the number of dwellings to the number of buildings in the national level was approximately 1.7. The ratios for the Durrës and Tirana prefecture, *i. e.* the most affected regions, were approximately 1.8 and 2.4. However, currently, the ratios are believed to be higher. Around half of the population dwell in single-storey buildings, while the other half dwell in buildings ranging from two stories up-to multi-storey buildings. The main structural systems used in the buildings comprise: confined and unconfined unreinforced masonry, RC frames, dual systems with lightweight infills, and prefabricated RC panels.

3.1 Population of Albania

The country of Albania is divided into 12 prefectures and 61 municipalities. The municipalities are further sub-divided into cities and villages. According to the Institute of Statistics (INSTAT) of Albania, the estimated population as of January 1st, 2019, is 2,862,427 [3.3]. The distribution of the population between the regions is illustrated by the following pie-chart, in which it can be observed that Tirana has the highest number of inhabitants.

Figure 3.1: Distribution of the population among the regions of Albania

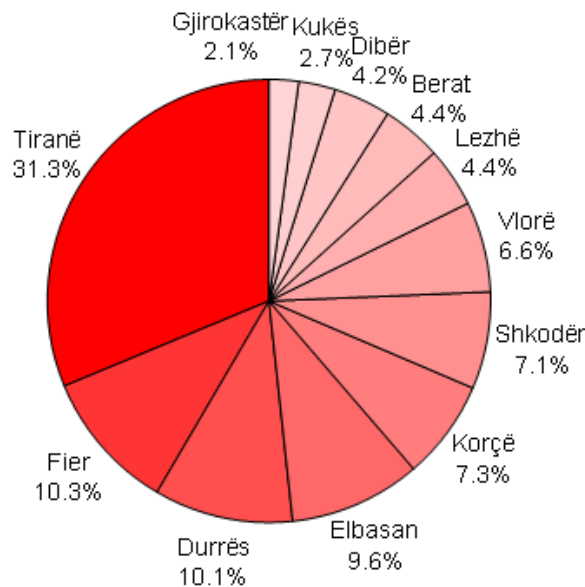

Source: INSTAT, population 2019 [3.3]

3.2 Building stock of Albania

According to the housing census conducted in 2001 by INSTAT [3.1], in addition to other classifications, the buildings are classified based on the main construction material, see Table 3.1 and Figure 3.2. This census is not the most recent, however, it is referred to consistently, as it is the last one that provides a classification based on construction materials. Thus, one can infer

information about the mechanical properties of the buildings. The classification is of four typologies *i.e.*, prefabricated, bricks and stones, wood, and other construction material. The selection of a class is based on the material of infills and façade walls. The category “bricks and stones” includes brick, stone masonry structures, and RC structures. The figures are on the national level.

Table 3.1: Number of residential buildings by year of construction and the main material type according to INSTAT 2001

Construction material	Pre-1945	1945-1960	1961-1980	1981-1990	1991-1995
Prefabricated concrete	0	0	4,601	5,993	4,575
Bricks & Stones (Masonry and RC structures)	37,416	63,870	141,174	102,198	43,324
Wood	462	-	1821	1,273	743
Other	2,560	3,393	7105	6,263	4,238
Total	40,438	68,468	154,701	115,727	52,880

Figure 3.2: Distribution of housing buildings by main construction material

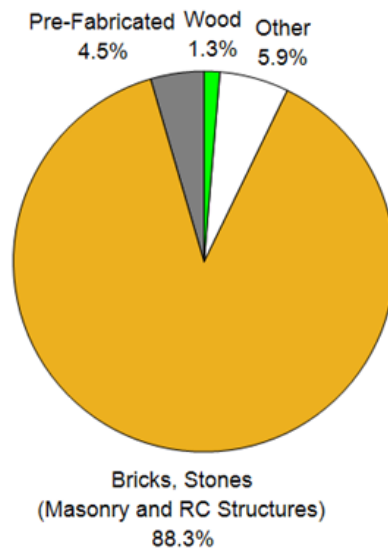

Source: INSTAT Census 2001 [3.1]

The housing building stock comprises of low- to high-rise buildings. Single-storey buildings account for 85% of the total number of buildings according to the 2011 census [3.2] as shown in Figure 3.3. By assuming that a single-storey building accommodates a single dwelling, it can be stated that they account for 50% of the 1,012,400 dwellings in the portfolio. Following a similar assumption, it can be estimated that 50% of the population lives in buildings with two or more storey. The load-bearing system of the single-storey building can be unconfined masonry, confined masonry or RC frames with lightweight clay or concrete brick infills. The same systems are used for the two-storey buildings. The roof of the buildings can be made up of a flat RC slab

or a traditional roof that combines wooden trusses or rafters and clay tiles. Sometimes roofs can be inclined RC slabs that are covered with clay tiles for aesthetic purposes.

The most common multi-storey building typologies are clay or calcium silicate brick masonry and RC structures with lightweight masonry infills, where all the buildings above 6 storeys are of RC frames or dual system. Both unconfined and confined masonry structures have been utilized for multi-storey buildings. Precast wall panel buildings, that fall on the ‘pre-fabricated’ category of the 2001 census [3.1], usually go up to 6 stories. Figure 3.4 depicts some characteristic multi-storey housing buildings in Albania. The roofs of the multi-storey buildings are almost always made of flat RC slabs. Table 3.2 and Figure 3.5 present the development of the number of buildings over time. At least 31% of the buildings were constructed before 1990. In this period, masonry structures were widely used for both residential and public buildings [3.4]. The use of prefabricated multi-storey concrete buildings, mainly for housing purposes, started after 1960. A significant number of dwellings belong to this category [3.5]. After 1990 a significant growth in the number of buildings has been observed [3.5], mainly with respect to the number of single-storey, two-storey, and multi-storey buildings. After 1990, especially until 2000, owing to the poor law enforcement, numerous buildings, mainly low-rise, were constructed without permission from the authorities. Besides, illegal interventions to the existing buildings, such as creating openings in the load-bearing masonry walls, adding floors on the top or side of buildings, are widespread. Having been built without proper engineering assurance, this kind of buildings may pose a high risk to their occupants and the community.

At least 39% of the buildings were constructed after 1990, whereas for 30% of the buildings the construction period is unknown. The multi-storey buildings built during that period consist mostly of RC frames or dual systems.

Figure 3.3: Number of buildings by number of stories according to INSTAT 2011 Census

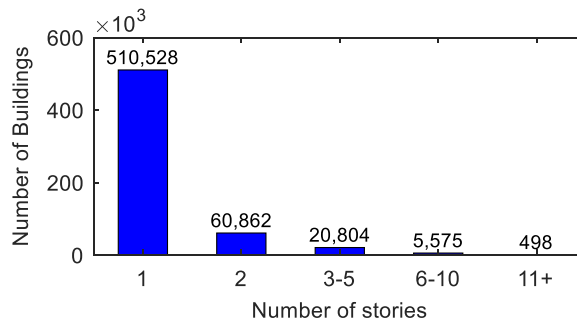

Source: INSTAT 2011 Census [3.2]

Figure 3.4: Representative typologies of Albanian multistory residential building stock

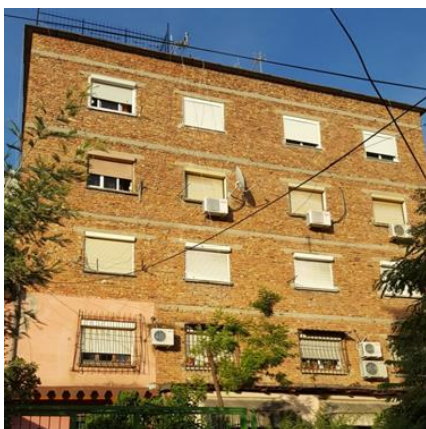

a) Clay brick masonry building



b) Calcium-Silicate brick building



c) Prefabricated RC panel building



d) New RC building (under construction)

Table 3.2: Number of residential buildings by construction year and number of stories

Number of floors	Pre-1960	1961-1980	1981-1990	1991-2000	2001-2005	2006-2011	Unknown year	Total
1	37,418	67,404	56,826	102,665	45,242	39,110	161,863	510,528
2	5,383	6,393	4,190	16,382	8,059	6,052	14,403	60,862
3-5	1,199	4,192	3,304	4,474	2,527	1,876	3,232	20,804
6-10	190	492	612	870	1,094	1,661	656	5,575
11+	5	14	11	83	214	148	23	498
Total	44,195	78,495	64,943	124,474	57,136	48,847	180,177	598,267

Figure 3.5: Number of buildings by the period of construction according to INSTAT 2011 Census

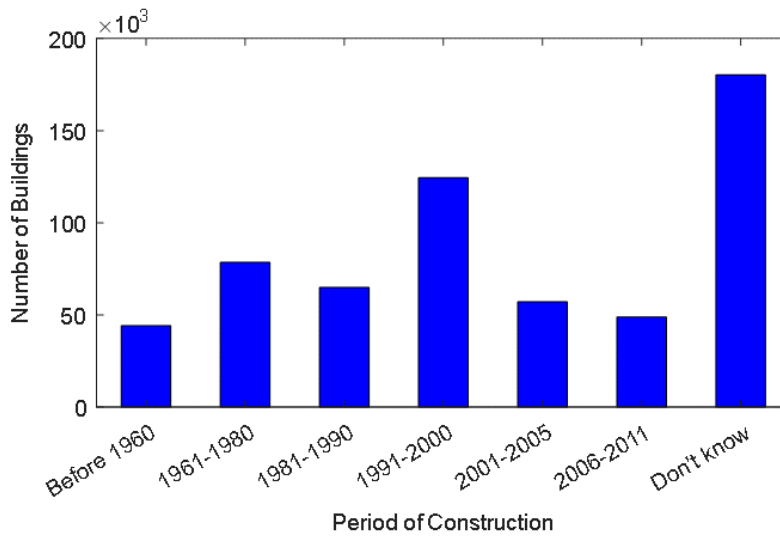

Source: INSTAT 2011 Census [3.2]

3.3 References for chapter 3

- [3.1] Albanian Institute of Statistics. Population and Housing Census 2001. Available online: <http://www.instat.gov.al/al/temat/censet/censusi-i-popullsis%C3%AB-dhe-banesave/#tab2> (accessed on 21 March 2020). (In Albanian)
- [3.2] Albanian Institute of Statistics. Population and Housing Census 2011. Available online: <http://www.instat.gov.al/al/temat/censet/censusi-i-popullsis%C3%AB-dhe-banesave/#tab2> (accessed on 21 March 2020). (In Albanian)
- [3.3] Albanian Institute of Statistics. Population 1 January 2019. Available online: <http://www.instat.gov.al/en/themes/demography-and-social-indicators/population/#tab2> (accessed on 21 March 2020). (In Albanian)
- [3.4] Bilgim, H., Huta, E., 2018 "Earthquake Performance assessment of low and mid-rise buildings: Emphasis on URM buildings in Albania," Earthquake and Structures, Vol. 14, No. 6.
- [3.5] Novikova, A., Szalay, Z., Simaku, Gh., Thimjo, T., Salamon, B., Plaku, Th., Csoknyai, T., 2015, "The typology of the residential building stock in Albania and the modelling of its low-carbon transformation" Support for Low-Emission Development in South Eastern Europe (SLED). Available online: <http://sled.rec.org/building.html>. (accessed on 21 March 2020)

4 Evolution of Albanian seismic building codes

Albania has a long history of code-regulated seismic design, as shown in Table 4.1. The first seismic regulations, accompanied by the first Seismic Zoning Map of Albania, were adopted in 1952. The revision of 1963 increased the seismic design demands while the revision in 1978 brought no significant improvements [4.7]. The first seismic design code considered the seismic load based on the static method [4.11], without regard to the dynamic properties of the structures. With the introduction of the 1963 standard, the seismic load has been determined by considering its intrinsic dynamic effect on the structures. In 1989 the new seismic design code, KTP-N.2-89 [4.9], was released and it is currently the official code in Albania. It is essential to mention that regardless of the seismic design code's existence, as presented in section 3.2, numerous buildings are not code-compliant, and numerous buildings have been subjected to the illegal interventions in their load-bearing systems. In the following subsections, the KTP 2-78 and the KTP-N.2-89 are briefly presented.

Table 4.1: Seismic design codes of Albania and corresponding enforcement period

Seismic Design Code of Albania	Time Period
KTP 52	1952-1963
KTP 63	1963-1978
KTP 2-78	1978-1989
KTP-N2-89	1989- onward

4.1 Seismic design code of 1978, KTP 2-78

The KTP 2-78 [4.8] was based on the design code KTP 63 and the experience gained from the seismic design and the performance of the retrofitting measurements that had been applied in the damaged buildings due to seismic events in Albania. The seismic hazard of Albania is presented through the seismic hazard map of macroseismic intensities according to the MSK-64 scale [4.4]. The map divides the territory of Albania into three macroseismic zones with intensity VI, VII and VIII, see **Error! Reference source not found.** For structures located in areas with seismic intensity VI, no seismic design is required. On the other hand, for important structures or for structures located in poor soil conditions, the seismic intensity shall be increased by one intensity level. The code covers a broad range of structures, ranging from residential, industrial buildings to towers, chimneys, and hydraulic structures. It includes principles common to many modern seismic design codes for building structures, regarding the regularity in plan and elevation, uniform distribution of masses and stiffnesses, the use of lightweight materials, etc.

The seismic design forces at each story level shall be computed based on the following expression and by utilizing the modal response spectrum analysis of structures.

$$S_k = Q_k K_e \beta m_k$$

where:

Q_k , is the seismic weight which corresponds to the gravitational load lumped at the degree of freedom k considered for the calculation of seismic effects, as shown in Figure 4.2. It includes

permanent gravitational loads and a fraction of imposed loads associated with the degree of freedom k.

Figure 4.1: Seismic hazard map in KTP-2-78, in MSK-64 macroseismic intensity scale

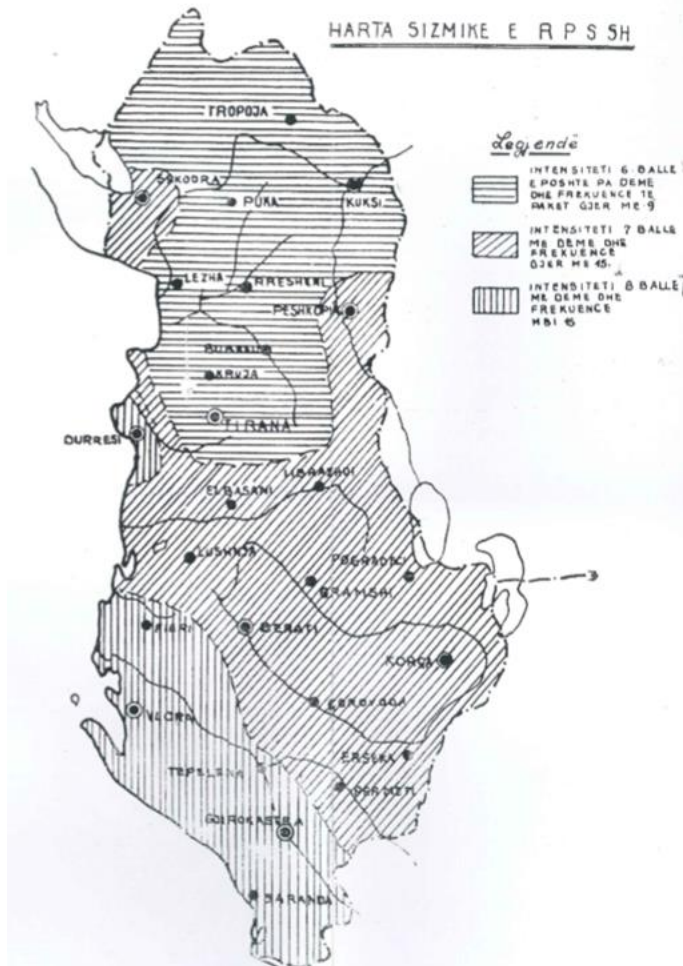

Source: horizontal hatch – VI, diagonal hatch – VII; vertical hatch - VIII

Figure 4.2: Lumped weights on an idealized shear type building (adapted from KTP 2-78)

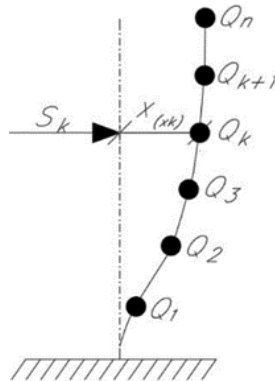

K_e , is the seismic coefficient which is function of seismic intensity as provided in Table 4.2. It is the ratio of peak ground acceleration to the gravitational acceleration and includes the soil amplification factor.

β , is the dynamic coefficient, that accounts for the effect of dynamic properties of the structure on the seismic load, computed based on the following formula:

$$0.6 \leq \beta = \frac{0.9}{T} \leq 3$$

where T , is the fundamental vibration period of the structure.

m_k , is the form coefficient that depends on the deformed shape of the building during the free vibrations and the seismic weights, Q_j . The coefficient m_k is computed based on the formula:

$$m_k = \frac{X_{(xk)} \cdot \sum_1^n Q_j X_{(xj)}}{\sum_1^n Q_j \cdot X_{(xj)}^2}$$

$X_{(xk)}, X_{(xj)}$, are the horizontal displacements of seismic weights k and j during the free vibrations

Table 4.2: Seismic coefficient K_e , given in KTP 2-78

Seismic intensity (MSK-64)	K_e
VII	0.025
VIII	0.05
IX	0.10

For the seismic design of regular buildings, only the first mode of vibration is considered, whereas for flexible structures (e.g., chimneys, towers) higher modes are to be considered.

Regarding unreinforced masonry (URM) structures, the code limits the maximum storey heights and the wall slenderness based on the seismic intensity and seismic strength wall category, see Table 4.3 and Table 4.4. The masonry walls are classified into four categories based on the masonry unit types and mortar types, in which the best quality is the category I, Table 4.4. There are also requirements related to maximum dimensions in plan and elevation, the dimensions of

openings, and to other geometrical parameters of masonry buildings. On the other hand, for RC buildings there are no limitations on the dimensions of the buildings in plan and elevation, except for areas prone to seismic intensity IX, where the maximum allowed height is 45 m. The code recommends making use of plastic deformations, yet there are no recommendations as to how to achieve post-yielding deformation capacities in plastic hinges and no detailing rules of the structural members i.e. beams, columns, and walls are provided. Besides, the code does not enforce limits on inter-storey drifts for the protection of infills even though there is a requirement regarding the minimum strength of the mortar of infills.

Guidelines regarding all the members which masonry buildings are comprised of, namely, roofs, walls, foundations, tie beams, lintels, and partitions are provided. Provisions for determining seismic forces on non-structural components, e.g. infill walls, parapets, components are provided.

The code is not a capacity-based design code and does not restrict inter-storey drifts for protecting infills in RC structures. Concerning RC structures, the code is not comprehensive with respect to design and detailing recommendations of RC members, whereas the design and detailing of URM buildings is extensively covered. The ductility and soil factor do not explicitly appear in the formula for determining the seismic load, but the code recognizes that for soft soil conditions the design seismic intensity shall be increased by 1 intensity level.

Table 4.3: Maximum height, H, and slenderness ratio H/a where a is the wall thickness, of walls according to KTP 2-78

Wall category	Intensity VII		Intensity VIII		Intensity IX	
	H (m)	H/a	H (m)	H/a	H (m)	H/a
1	8	16	7	14	6	12
2	7	14	6	12	5	9
3	6	12	5	9	–	–
4	5	9	–	–	–	–

Table 4.4: Seismic strength categorization of walls according to KTP 2-78

No.	Wall type	Wall Category, for walls bonded with cement, cement-lime, or cement-clay mortar, as a function of the mortar mean strength			Wall Category for walls bonded with lime mortar
		50 dN/cm ²	25 dN/cm ²	10 dN/cm ²	
–	–	–	–	–	–
A	Walls composed of bricks: (artificial stone is the original term used in the code):				
1	Clay (red) bricks, Calcium silicate bricks	1	2	3	4
2	Hollow bricks	1	1	3	4
3	Adobe bricks	–	–	–	4
4	Concrete blocks with mean strength not less than 50dN/cm ² :				
	solid	1	2	3	4
	hollow	2	3	4	–

No.	Wall type	Wall Category, for walls bonded with cement, cement-lime, or cement-clay mortar, as a function of the mortar mean strength			Wall Category for walls bonded with lime mortar
		50 dN/cm ²	25 dN/cm ²	10 dN/cm ²	
5	Concrete block with mean strength 25dN/cm ² :				
	solid	–	3	3	4
	hollow	–	3	4	–
B	Walls built of natural stones with regular shape:				
6	Bricks made of soft stone (limestone, etc.,) with mean strength not less than 50 dN/cm ²	1	2	3	4
C	Walls made of rubble stones:				
7	Flat stones	3	3	4	–
8	Carved stones	–	4	4	–
9	Round stones	–	4	–	–

4.2 Seismic design code of 1989, KTP-N.2-89

The KTP-N.2-89 [4.9] is currently the official seismic code in Albania. This code covers a broad range of structures that may be subjected to earthquake ground motions. The concept underlying the code ensures to provide the structures with the capacity to dissipate energy through nonlinear cyclic deformations without compromising its structural integrity. It includes principles common to many modern seismic design codes for building structures, such as the regularity in plan and elevation including considerations on the masses, the stiffnesses, symmetry, simplicity, etc. The seismic hazard is presented through the macroseismic intensity map according to the MSK-64 scale, see Figure 4.3. The map divides the country in three large area seismic zones with intensity VI, VII, VIII. It also denotes some certain areas around epicentres of known large earthquakes where the seismic intensity VIII is increased by one intensity level to IX. The rules presented in the code applies mainly to structures located in areas with seismic intensity greater than VI. For buildings located in areas with seismic intensity VI some simple detailing rules are defined.

Figure 4.3: Seismic hazard map in KTP-N2-89, in MSK-64 macroseismic intensity scale

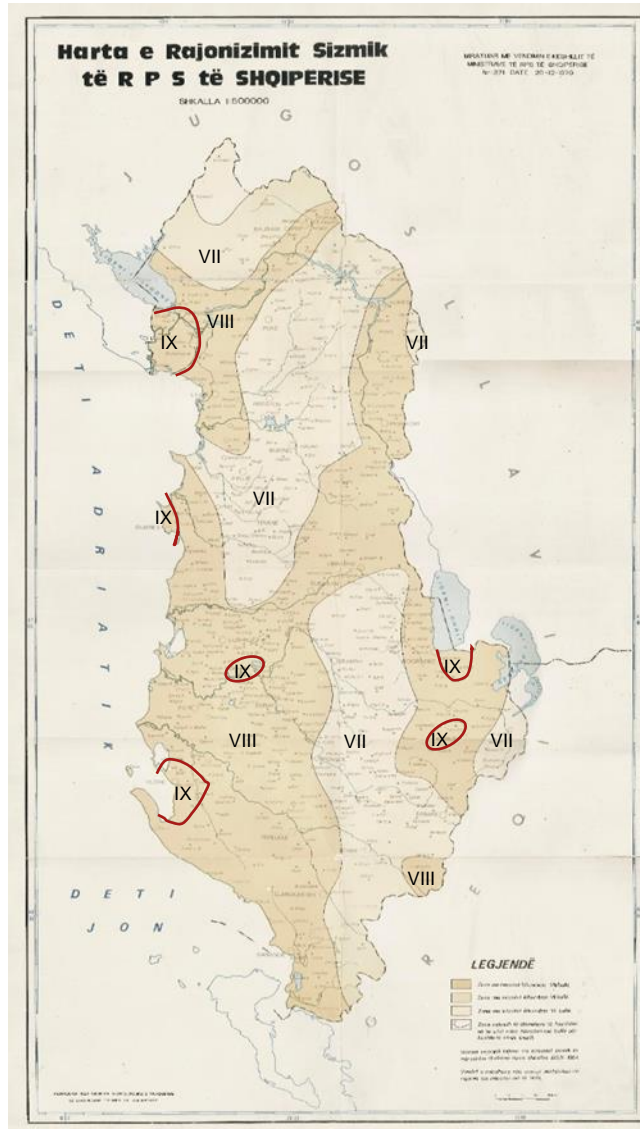

The seismic analysis methods include the modal response spectrum analysis or time history analysis for more complex structures. The design spectral accelerations are determined according to the following equation:

$$S_a(T) = k_E k_r \psi \beta g$$

where:

k_E , is the coefficient of seismicity as reported in Table 4.5. The coefficient represents the ratio of the peak ground acceleration to the gravitational acceleration.

k_r , is the building importance factor, e.g., for ordinary buildings is equal to 1, for buildings that are important for post-earthquake recovery is 1.5, for buildings whose damage may cause

serious consequences to the life safety of its occupants for e.g. schools, theatres, etc is 1.3, etc.

ψ , the dynamic structural response coefficient, Table 4.6. It accounts for the capacity of structural systems to resist seismic actions in the non-linear range which permits the structures to be designed for reduced seismic forces as compared to the case when the structures respond elastically.

β , is the dynamic factor that accounts for the effect of dynamic properties of the structure on the design spectral acceleration and is function of the period of structure, T , and the soil category, Table 4.8

Table 4.5: Seismic coefficients according to KTP-N.2-89

Soil category	Intensity VII	Intensity VIII	Intensity IX
I	0.08	0.16	0.27
II	0.11	0.22	0.36
III	0.14	0.26	0.42

Table 4.6: Dynamic response factor ψ of buildings according to KTP-N.2-89

Structural type	Structural coefficient ψ
Steel frames	0.2
RC frames without the consideration of frame-infill interaction:	
H/b ≤ 15	0.25
H/b ≥ 25	0.38
15 < H/b < 25	Linear interpolation
h-column height	
b-the cross-section dimension perpendicular with the direction of the seismic load	
RC frames with the consideration of frame-infill interaction:	0.3
RC dual structures	0.28
RC wall structures (cast in-situ or prefabricated large panels)	0.30
Unreinforced masonry	0.45
Confined masonry	0.33

Table 4.7: Dynamic factor β , according to KTP-N.2-89

Category I – rock	Category II – weathered rock, stiff and medium soil	Category III – soft soil
$0.65 \leq \beta = \frac{0.7}{T} \leq 2.3$	$0.65 \leq \beta = \frac{0.8}{T} \leq 2$	$0.65 \leq \beta = \frac{1.1}{T} \leq 1.7$

Guidelines are provided for the seismic design load calculations, for the definition of torsional effects, load combinations in the case of seismic design situation and of the partial factors in the load combinations. The code also gives limits related to the maximum dimensions in plan and elevation for different types of buildings. A section is devoted to the design of seismic joints of buildings, the distance between seismic joints and their widths.

Even though the code is broad and details multiple type of structures hereinafter details are presented for unreinforced masonry and cast in-situ RC buildings.

Concerning unreinforced masonry structures (URM), the materials' mechanical properties shall comply with the code minimum requirements. The masonry walls are classified in three seismic strength categories based on the mortar strength and masonry unit properties, Table 4.8. There are limitations on the heights of stories as a function of the thickness of wall and wall category, see Table 4.9, and limitations on the maximum distances between transversal walls (Table 4.10). Limitations on the dimensions of openings, distances between consecutive openings, and other geometrical parameters are imposed in the code. Masonry structures shall be provided with RC tie beams and the beams should comply with the detailing rules as to the stirrups and longitudinal rebars diameters, spacing, etc. The code also imposes detailing rules for confined masonry structures.

Table 4.8: Seismic strength categorization of walls according to KTP-N.2-89

No.	Wall type	Wall Category as a function of the mortar mean strength (dN/cm ²)		
		50	25	15
—	Wall made of:			
1	Clay Bricks: solid or with vertical holes	I	II	III
2	Calcium silicate bricks	II	III	—
3	Concrete blocks with mean strength not less than 100dN/cm ²	II	III	—
4	Stone with mean strength greater than 200 dN/cm ² :			
	a) Regular shape	II	III	—
	b) Irregular shape	III	—	—

Table 4.9: Maximum allowable storey heights according to KTP-N.2-89

Seismic intensity	Wall category	Maximum allowable storey height, h (m)	
		Wall thickness 25cm	Wall thickness 35cm
—	—		
VII	I, II and III	3.00	4.50
VIII	I	3.00	4.00
VIII	II and III	3.00	3.80
IX	I	2.80	3.60
IX	II and III	2.80	2.90

Table 4.10: Maximum spacing between transverse walls according to KTP-N.2-89

Seismic intensity	Maximum spacing between transverse walls (m)		
	Wall category I	Wall category II	Wall category III
—			
VII	11.00	10.00	4.50
VIII	9.00	8.00	4.50
IX	7.00	5.00	4.50

Concerning RC structures, the code recognize that the earthquake loads can be resisted by the following structural systems: frames, frames by interacting with the infills, braced frames and dual systems, or by a combination of the previously mentioned systems.

Detailing rules of the members of cast in-situ RC structures namely, beams, columns, walls shall comply with the requirements imposed by the code, see below:

- Table 4.11: Detailing rules for RC columns in KTP-N.2-89 & Figure 4.4 for RC columns
- Table 4.12: Detailing rules for RC beams according to KTP-N.2-89 & Figure 4.5 for RC beams
- Table 4.13: Rules for detailing of RC shear walls according to KTP-N.2-89 & Figure 4.6 for RC shear walls

Detailing shall guarantee that the plastic hinges occurs in the beams, yet there is no condition to ensure that this requirement is satisfied. The code limits maximum eccentricities between the beams and columns axes and it also limits the maximum width of beams in cases when beams are wider than columns.

There are no limits imposed on the inter-storey drifts to protect the infills by the in-plane loads even though the code requires that infills maintain their integrity during seismic events. It is also stated that the infills shall be checked against the out of plane failure. In this regard, there are guidelines provided on how to determine the seismic demand on non-structural components.

Table 4.11: Detailing rules for RC columns in KTP-N.2-89

Detailing item, RC columns	Seismic intensity VII and VIII	Seismic intensity IX
Min b	250 mm	250 mm
Max l/b_k	25	25 (15 for cantilevers)
Length of plastic hinge l_z	Max {h; $l/6$; 450mm}	Max {h; $l/6$; 450mm}
Minimum number of rebars	4 Φ 14 or 6 Φ 14 for circular columns with spiral stirrups	4 Φ 14 or 6 Φ 14 for circular columns with spiral stirrups
Development length l_b		
Max d_{st}	300	200
Max d	Min { $b_k/2$; 300mm}	Min { $b_k/2$; 200mm}
Max a_{st}	Min { b_k ; 12 Φ ; 300mm}	Min { b_k ; 10 Φ ; 200mm}
Max s_{tz}	Min { $b_k/2$; 10 Φ ; 150mm}	Min { $b_k/2$; 8 Φ ; 100mm}
Min Φ_{st}	6mm	8mm
Min Φ_{stz}	6mm	8mm
Max h_k/b_k	3	2

Figure 4.4: Column layout according to KTP-N2-89

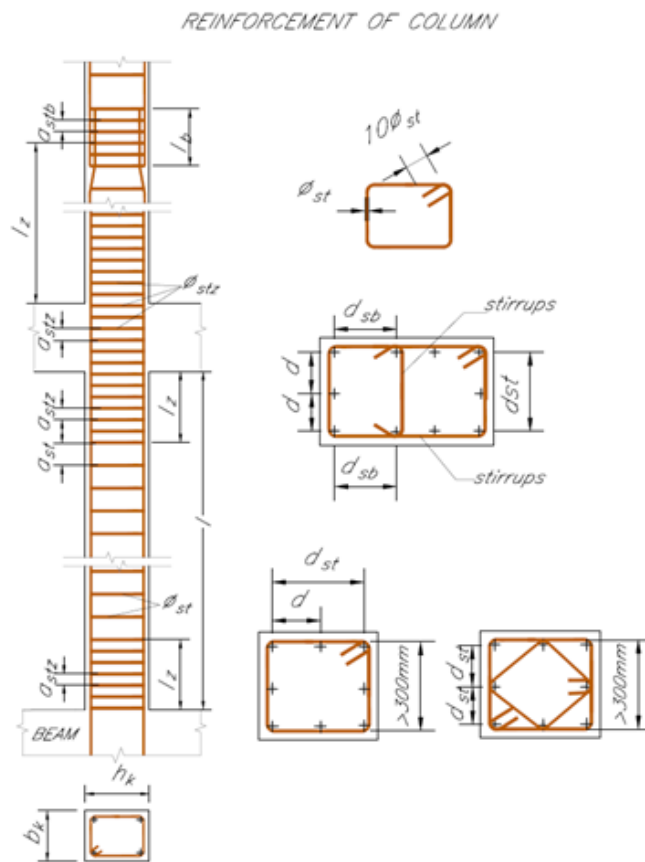

Table 4.12: Detailing rules for RC beams according to KTP-N.2-89

Detailing item, RC beams	Seismic intensity VII and VIII	Seismic intensity IX
Min b	200mm for intensity VII Max {200mm; 0.4h; 0.5b _k } for intensity VIII	Max {200mm; 0.4h; 0.5b _k }
Max b	$h_k + 0.5h \leq 2b_k$	$h_k + 0.5h \leq 2b_k$
Min h	300mm	300mm
Max h/b	4	4
l_{a1}	25 Φ	25 Φ
l_{a2}	12 Φ	12 Φ
a_{st}	Min {h/2; b; 250mm}	Min {h/2; b; 200mm}
a_{stz}	Min {h/4; b; 200mm}	Min {h/4; b; 150mm}
Min φ_{st} , φ_{stz}	6 mm	6 mm
Min l_1 ; min l_2 ; min l'_1 ; min l'_2	l/4	l/4
Length of plastic hinge l_z	2h	2h

Figure 4.5: Beam layout according to KTP-N2-89

REINFORCEMENT OF BEAM

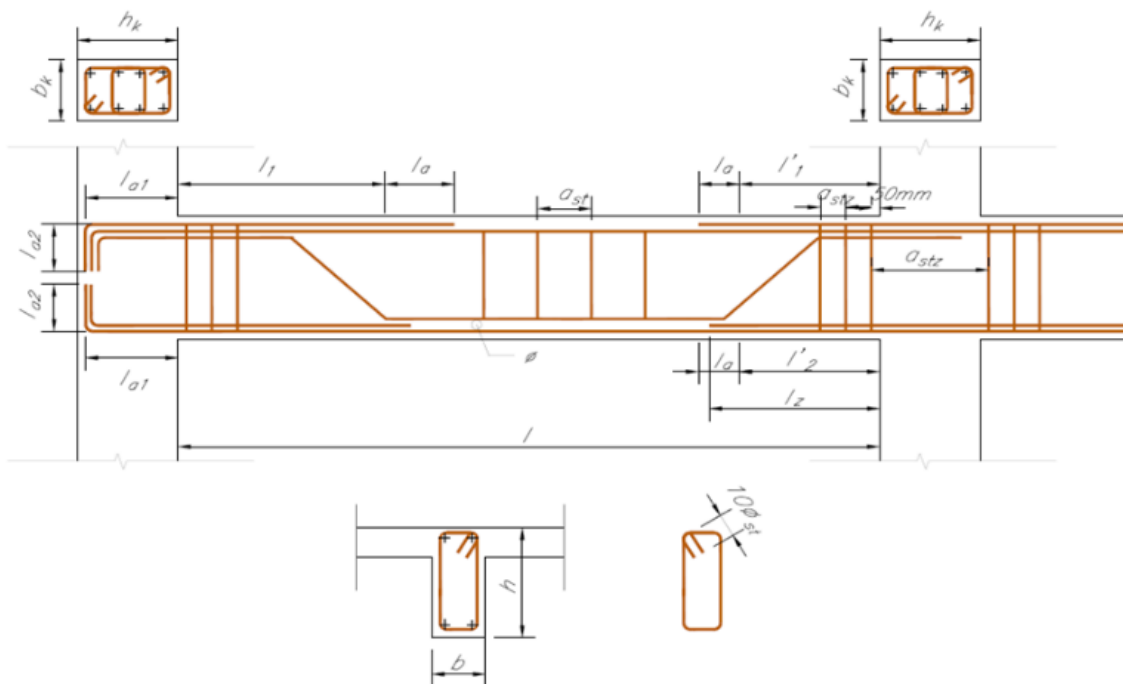
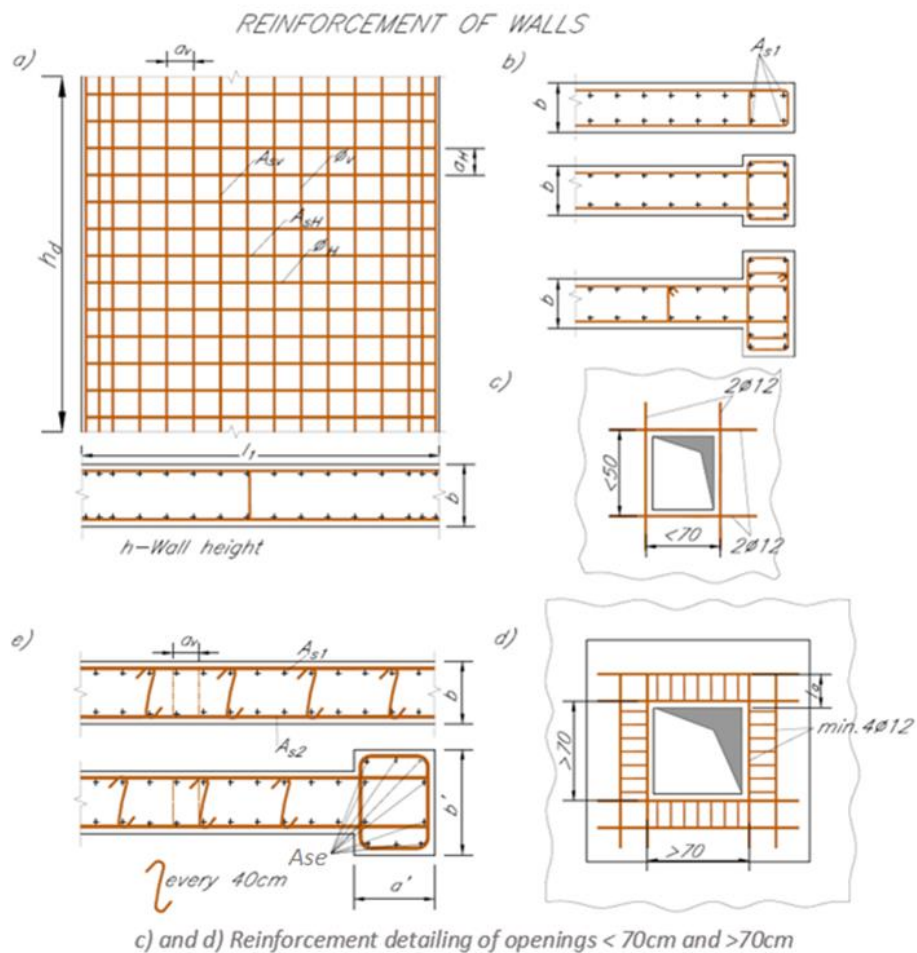

Table 4.13: Rules for detailing of RC shear walls according to KTP-N.2-89

Detailing item, RC beams	Seismic intensity VII and VIII	Seismic intensity IX
Min b	Max {140mm; 1/25h}	Max {140mm; 1/20h}
Max Φ_v ; max Φ_h	$b/10$	$b/10$
Max a_v ; max a_h	250mm	250mm
Min A_{se}	4 Φ 12	4 Φ 14
l_a	40 Φ	40 Φ
Stirrups	$\geq \Phi 6$ @150mm c/c	$\geq \Phi 6$ @100mm c/c
Minimum rebar ratios μ_H or μ_V without including rebars in confined zones	0.25%	0.25%
Maximum rebar ratio μ_V	3.5%	3.5%

Figure 4.6: Shear wall layout according to KTP-N2-89



4.3 The status of Eurocode 8 in Albania

The Eurocode 8 standard is yet to be adopted in Albania as a national seismic design code. Even though the standard is not an official code, it is understood that the community of structural engineers often uses it as a reference document in their everyday practice. Besides, the seismologists' community have come up with different hazard maps [4.1], [4.2], [4.3], [4.6] expressed in reference peak ground acceleration as required in Eurocode 8. Recently, the map produced by [4.2] has gained much consensus amongst the community of seismologists, Figure 4.7. Also, there are serious efforts to adopt Eurocode 8 [4.10] as the official seismic design code of Albania. These efforts have been accelerated after the Durrës earthquake of 26th November 2019. In the meantime, a significant amount of work toward the full adoption of Eurocode 8 is already concluded [4.5].

Figure 4.7: Reference PGA map of Albania for 475 years return period

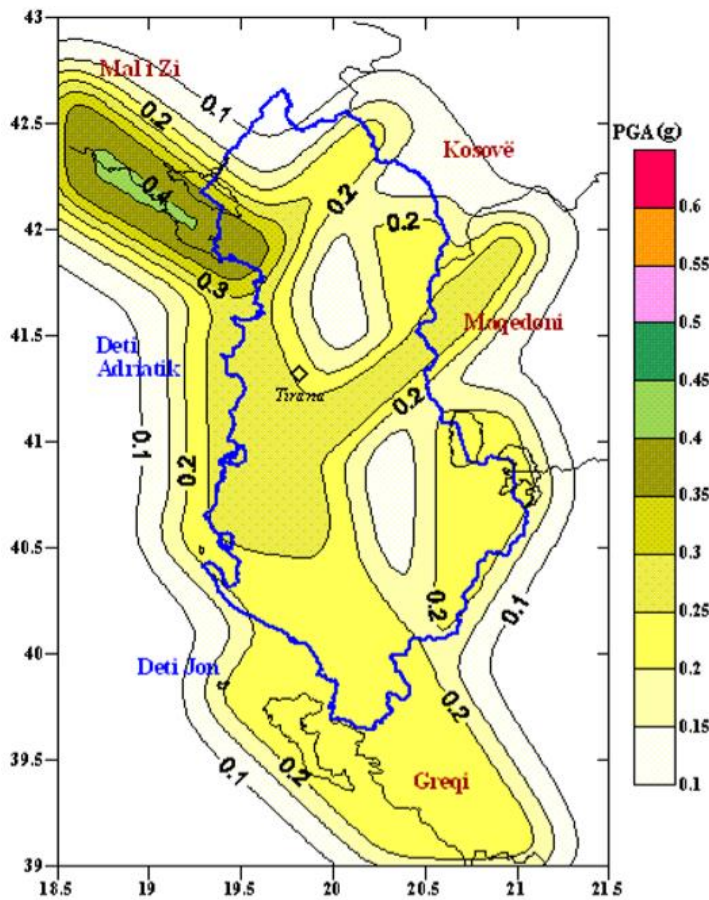

Source: Aliaj et al (2010) [4.2]

4.4 References for chapter 4

- [4.1] Aliaj, SH., Adams, J., Halchuk, S., Peci, V., Sulstarova, E., Muço, B., 2004, "Probabilistic seismic hazards maps for Albania", Proceedings of 13th World Conference on Earthquake Engineering, Vancouver, B.C., Canada.

- [4.2] Aliaj, SH., Koçiu, S., Muço, B., Sulstarova, E., 2010, "Seismicity, Seismotectonics and Probabilistic Seismic Hazard of Albania, Science Academy", Tirana, Albania.
- [4.3] Fundo, A., Duni, Ll., Kuka, Sh., Begu, E., Kuka, N., 2012, "Probabilistic seismic hazard assessment of Albania," Acta Geod. Geoph. Hung., Vol. 47, No. 4, pp. 465-479.
- [4.4] Guri, M. 2016 "Research on the state-of-the-art techniques related to the reinforcement of masonry structures," PhD. Thesis Dissertation, Faculty of Civil Engineering, Technical University of Tirana, Albania. (In Albanian)
- [4.5] Luka. R., 2018, "Present status of Eurocodes in Albania. The way forward for the Eurocodes implementation in Balkans", Tirana, Albania. Retrieved from: https://eurocodes.jrc.ec.europa.eu/doc/2018_10_WS_Balkan/presentations/1_Country_Report_Albania.pdf
- [4.6] Muço, B., 2013, "Probabilistic seismic hazard assessment of Albania," Ital. J. Geosci., Vol. 132, No. 2, DOI: 10.3301/IJG.2012.25.
- [4.7] UNDP, Albania, 2003, "Disaster management and emergency preparedness project, Risk assessment of Albania", Tirana, Albania.
- [4.8] KTP 2-78 (1978) "Technical Design Regulations for Construction Works in Seismic Regions", Technical Design Regulations, Book I, Publishing House "8 Nëntori", Ministry of Construction, Albania, pp.12-48. (In Albanian)
- [4.9] KTP-N.2-89, 1989, "Technical Aseismic Regulations," Publication of Academy of Sciences and Ministry of Constructions, Tirana, Albania. (in Albanian)
- [4.10] EN 1998-1, 2005, "Eurocode 8: Design of structures for earthquake resistance. Part 1: General rules, seismic actions, and rules for buildings," CEN
- [4.11] Seranaj, A. 2016, "Behaviour of reinforced concrete structures with hidden beams into the slab and beamless, in regions with medium and high seismicity," PhD. Thesis Dissertation, Faculty of Civil Engineering, Technical University of Tirana, Albania. (In Albanian)

5 The 26th November 2019 earthquake

On 26th November 2019 at 03:54 CET, an earthquake with moment magnitude M_w 6.4 and focal depth of 20 km struck northwest Albania. This strong earthquake caused extensive damage to at least 10 of the country's 61 municipalities, including the two most populous, urbanized and developed cities Tirana and Durrës. The worst affected municipalities were: Shijak, Durrës, Krujë, Tirana, Kamëz, Kavajë, Kurbin and Lezhë. This was the strongest earthquake in Albania for the last 40 years and the worldwide deadliest earthquake for 2019.

5.1 Earthquake intensity

According to the Albanian Institute of Geophysics, Water and Energy (IGEWE) at 03:54 on 26th November 2019, Albania was hit by an earthquake with a magnitude M_w 6.4 at a depth of 20 km with an epicentre 22 km north-east from Durrës and 30 km north-west from Tirana. This earthquake was preceded from a foreshock that occurred five hours earlier, at 21:59 on 25th November 2019, with a magnitude 3.5 on the Richter scale at a depth of 35 km and an epicentre located 19 km north of Durrës. These two events were preceded by an earlier earthquake, which hit 5 km north of Durrës city on 21st September 2019 with a magnitude of 5.6 on the Richter scale and with a depth of 10 km. The macroseismic intensity maps of the 26th November earthquake from EMSC [5.1] and USGS [5.2] are shown in Figure 5.1 and Figure 5.2.

Figure 5.1: EMS-98 intensity for the 26th November earthquake

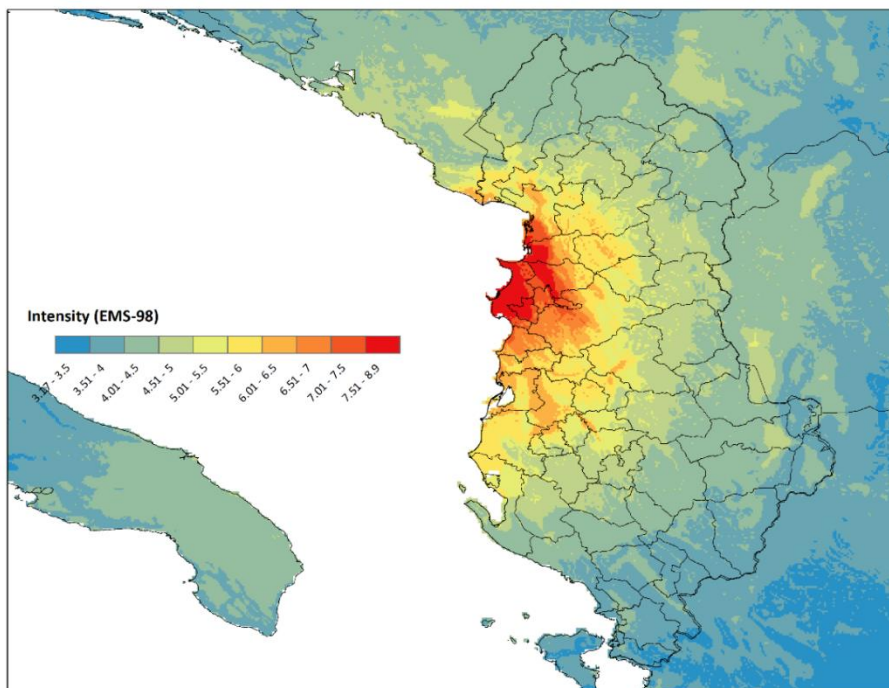

Source: EMSC macroseismic map [5.1]

Figure 5.2: ShakeMap intensity for the 26th November earthquake

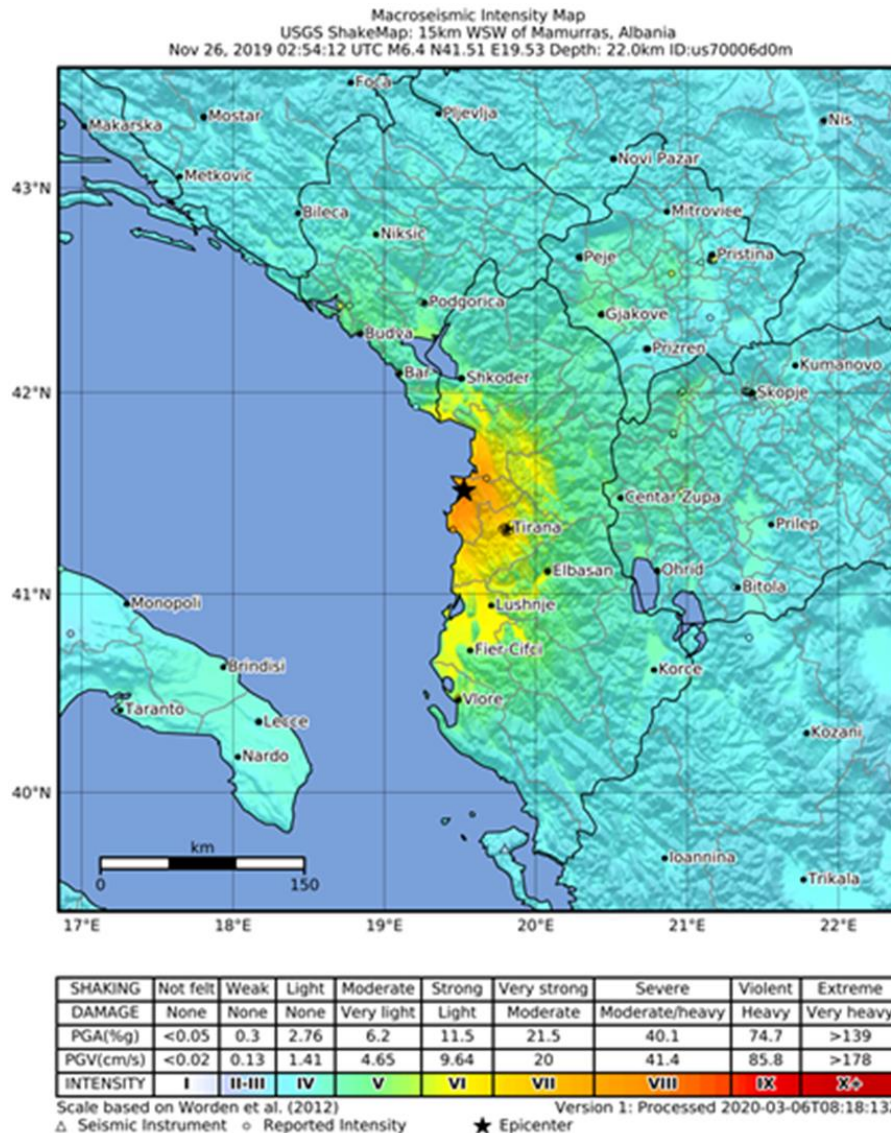

Source: USGS ShakeMap [5.2]

The Albanian Instituti i Gjeoshkencave, Energjise, Ujit dhe Mjedisit (IGEWE), provided public access to the strong motion records from the November earthquake [5.3] at <https://www.geo.edu.al/newweb/?fq=november>. Records from several stations, including Tirana were released and made public just few days after the earthquake. Unfortunately, the strong motion record was corrupted due to electric outage and the reconstructed record from the station in Durrës is available only for the first 15 seconds and was released at the end of February. The maximum Peak Ground Acceleration (PGA) for the first 15 seconds is ~0.20g. The reconstructed strong motion record from Durrës is shown in Figure 5.3: Strong motions recorded in Durrës during the 26th November earthquake. The response spectra from the reconstructed records compared with the elastic design response spectrum for Durrës for soft soil (consisted with the soil at the record location) are shown in Figure 5.4. As it can be seen the elastic design spectrum overlaps entirely the response spectra of the recorded strong motions having a significant margin

in the periods below 0.8s. However, in the natural period range of 1 to 2 seconds the spectrum of the recorded strong motion is comparable to the elastic design spectrum. However, it is worth mentioning that being the record representative only of a portion of the ground motion, the current representation could underrepresent the real spectrum. The peak horizontal acceleration recorded in Tirana was ~0.12g. The strong motion records registered in Tirana are shown in Figure 5.5: Strong motions recorded in Tirana during the 26th November earthquake . The response spectra from the Tirana records are compared in Figure 5.6 to the elastic design spectra as per the Albanian seismic design code KTP-N.2-89 for Durrës and Tirana. In Tirana, the recorded spectral accelerations in the fault normal direction (EW, blue line) are between 1.4 and 2.0 times higher than the code provision at spectral periods 0.2 to 1.0 sec where most buildings in the affected areas are expected to have their fundamental modes.

Figure 5.3: Strong motions recorded in Durrës during the 26th November earthquake

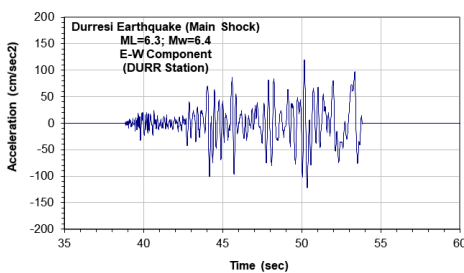

Source: IGEWE [5.3]

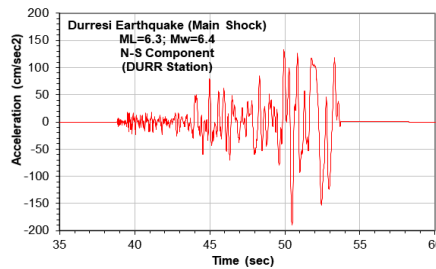

Source: IGEWE [5.3]

Figure 5.4: Response spectra of Durrës records vs KTP-N2-89 elastic demand

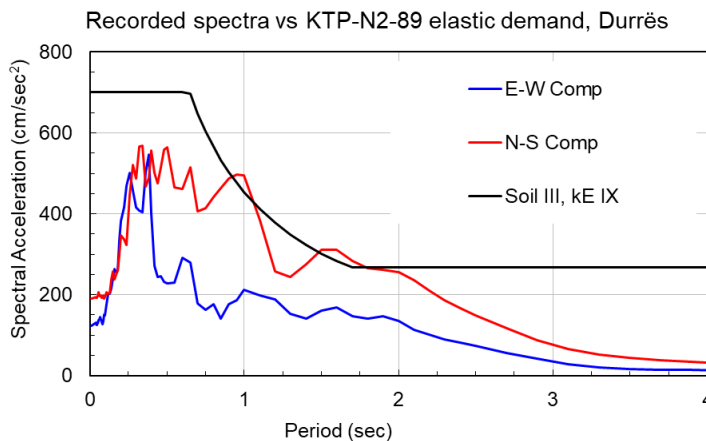

Source: IGEWE [5.3]

Figure 5.5: Strong motions recorded in Tirana during the 26th November earthquake

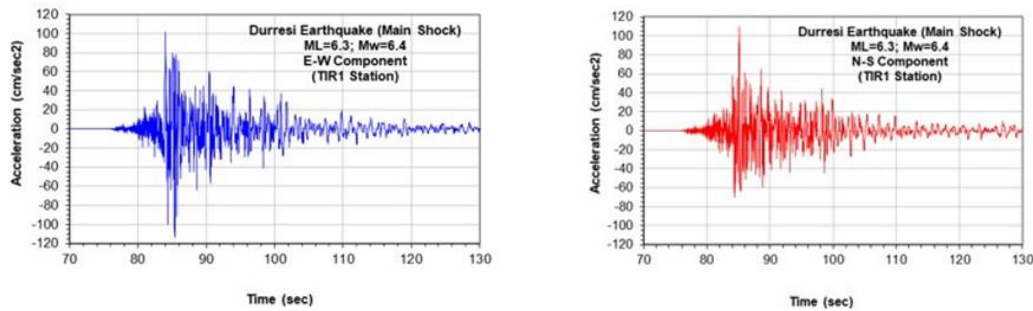

Source: IGEWE [5.3]

Figure 5.6: Response spectra of Tirana records vs KTP-N2-89 elastic demand

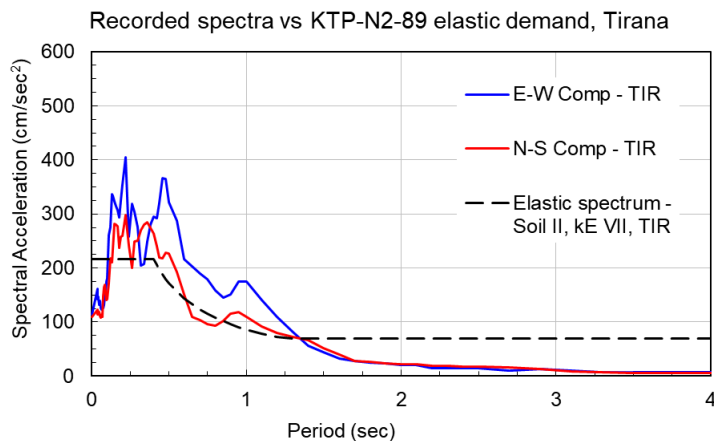

Source: IGEWE [5.3]

5.2 Damage and economic losses

Following the M_w 6.4 Durrës-Mamurras earthquake of 26th November 2019, a rapid post-disaster damage assessment, following the Global Rapid post-disaster Damage Estimation² methodology, was undertaken by the World Bank (WB). The objective of this assessment was to estimate the economic damages caused by the event and understand the spatial distribution of damages to support the process of developing a roadmap for recovery and reconstruction. Damage to buildings and infrastructure caused primarily from the strong ground motion was assessed using a combination of government damage data; hazard modelling of the earthquake ground motion footprint; development of a buildings and infrastructure exposure database via census and capital stock information; and the assignment of structural vulnerability functions to

² https://www.gfdr.org/sites/default/files/publication/DRAS_web_04172018.pdf

existing structural typologies in Albania. Economic damage estimation results for the four most affected municipalities in the epicentral zone, as well as groups of municipalities in Tirana, north and south of the epicentral zone, and in the rest of the country were determined.

Figure 5.7 and Figure 5.8 show the estimated replacement costs and the relative impacts as a percentage of Total Exposure Value (TEV) for six sectors: residential (housing), infrastructure, education, health, commercial/public and industrial. The damage estimates cover buildings and contents. The analysis at this point does not evaluate the impact on loss in terms of economic flow (e.g., business interruption), it only assesses economic damage to capital stock.

Figure 5.7: Estimate of the breakdown of the economic damage in absolute values (in million USD). The yellow bars highlight the damage severity in each zone relative to the damage in the epicentral zone for the sector

Affected Zones (Municipalities)	Residential	Infrastructure	Education	Health	Commercial / Public	Industrial	TOTAL
Epicentral Area (Durrës, Krujë, Shijak, Vorë)	301.7	20	21.5	8.6	49.0	27.8	428.6
Tirana and Kamëz	202.7	7.2	12.6	4.0	23.2	12.8	262.5
North of Durrës (Lezhë, Kurbin, Mirditë)	33.5	0.9	2.1	0.5	2.6	1.4	41.0
South of Durrës (Kavajë, Peqin, Rrogozhinë)	33.9	0.7	0.6	0.4	2.4	1.4	39.4
Rest of Albania	44.9	0.4	1.1	0.3	1.6	0.8	49.1
TOTAL	616.7	29.2	37.9	13.8	78.8	44.2	820.6

Source: Table 1 in “M6.4 Albania earthquake global rapid post disaster damage estimated (GRADE) report” [5.4]

Figure 5.8: Estimate of the breakdown of the relative economic damages as percentage of total exposure value for the sector

Affected Zones (Municipalities)	Residential	Infrastructure	Education	Health	Commercial / Public	Industrial	TOTAL
Epicentral Area (Durrës, Krujë, Shijak, Vorë)	13.3%	1.5%	15.6%	12.7%	11.2%	10.4%	9.5%
Tirana and Kamëz	3.9%	0.2%	3.8%	2.5%	2.3%	2.1%	2.5%
North of Durrës (Lezhë, Kurbin, Mirditë)	4.1%	0.2%	3.1%	2.0%	1.8%	1.6%	2.5%
South of Durrës (Kavajë, Peqin, Rrogozhinë)	4.5%	0.1%	1.6%	1.6%	1.6%	1.4%	2.6%
Rest of Albania	0.4%	0.0%	0.1%	0.1%	0.1%	0.1%	0.2%
TOTAL	3.2%	0.3%	2.9%	2.4%	2.2%	2.0%	2.1%

Source: Table 2 in “M6.4 Albania earthquake global rapid post disaster damage estimated (GRADE) report” [5.4]

Later on in December 2019 and January 2020, the above mentioned post-disaster damage assessment was developed further in the form of Post-Disaster Needs Assessment (PDNA) that was realised through collaborative efforts of the Government of Albania and its international partners: the European Union, the United Nations agencies, and the World Bank. The work is summarised in the PDNA report [5.5].

The PDNA report [5.5] reveals that the estimated total effect of the disaster in the 11 municipalities amounts to 985 million euro, of which 844 million euro represent the value of destroyed physical assets and 141 million euro refer to losses. The sector-specific damages and losses are shown

in Figure 5.7 (Table 1 in the PDNA report). Most of the damage is recorded in the Housing sector (78.5%), followed by the Productive sector (8.4%) and the Education (7.5%) sector. Regarding the losses, the Productive sector accounts for the highest share (56.4%), followed by Housing (24.1%) and Civil Protection (CP) & Disaster Risk Reduction (DRR) with 9.4%. Relevant to the ownership of the effects, overall, 76.5% are private and 23.5% public. The Housing and Productive sectors constitute mainly private infrastructures, whereas the other remaining sectors are mostly publicly owned. The same pattern also applies for the losses.

In relation to the geographic distribution of damage and loss, the municipality of Durrës was overwhelmingly the most affected with 304 million euro or 32.4% of the total damage and loss, followed closely by Tirana with 284 million euro or 30%, and then Krujë with 84 million euro or 9%, as shown in Figure 5.10

Figure 5.9: Damage and losses per sector and sub-sector

Sectors	Sub-sectors	Damages	Losses	Total
In million EUR				
Health		8.02	1.91	9.93
Education		63.59	8.76	72.35
Housing		662.30	34.00	696.30
Productive		70.82	79.66	150.48
	Business and Employment	47.48	5.47	52.95
	Tourism	16.71	73.53	90.24
	Cultural Heritage	5.31	0.44	5.75
	Agriculture	1.32	0.22	1.54
Infrastructure		30.41	3.01	33.42
	Community Infrastructure	6.06	0.16	6.22
	Roads	4.83	0.43	5.26
	Water and Sanitation	0.35	0.00	0.35
	Communication	0.92	0.16	1.08
	Public Buildings	10.07	2.26	12.33
	Energy	8.18	0.00	8.18
Social Protection		-	0.62	0.62
Civil Protection and DRR		8.75	13.22	21.97
Total		843.89	141.17	985.06

Source: Table 1 in Albania PDNA report [5.5]

Figure 5.10: Damage and losses disaggregation by municipality

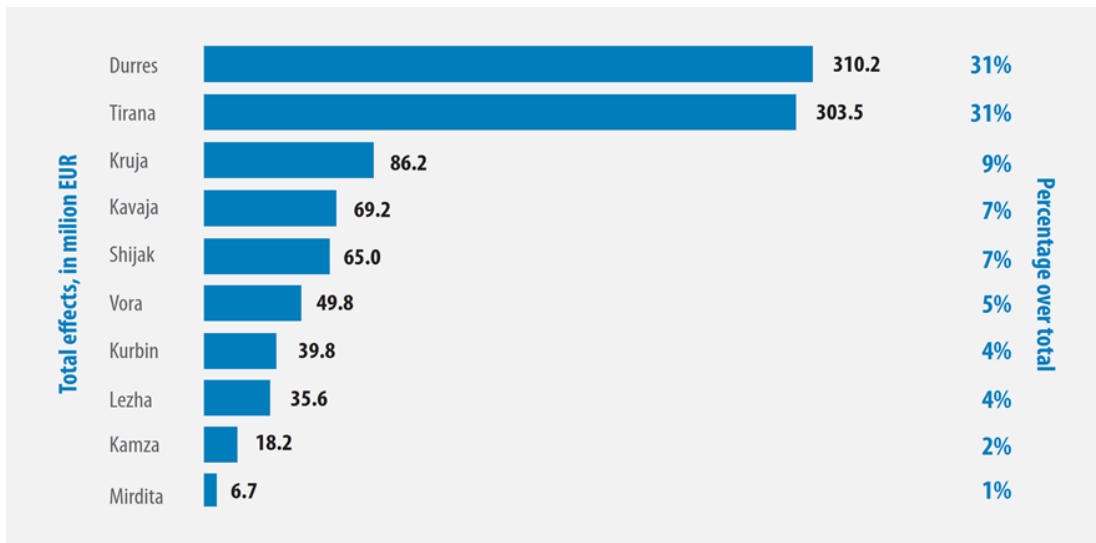

Source: Table 1 in Albania PDNA report [5.5]

The key findings of the PDNA [5.5] are summarised below and presented by sector:

- Education:** Damages were reported to 321 educational institutions in the 11 affected municipalities, representing 24% of all educational establishments. The municipalities of Tirana and Durrës have the highest share of damage, with 55% and 21%, respectively. The total value of damage and losses in the education sector is estimated at 72 million euro. Of this, the value of damage is 64 million euro, while the losses are 8.8 million euro. The total needs for reconstruction and recovery are estimated to be 94 million euro.
- Health:** 36 health facilities (8% of total in 11 Municipalities) were partially or fully damaged, where 22 are primary health care facilities. There were damages to three regional hospitals, nine university hospitals (units), two municipal hospitals, ten health centres, and 12 health posts. The total effects are estimated at 9.9 million euro. The reported losses amount to 1.9 million euro and are mainly linked to the free medical services during the emergency period. The recovery that considers the rehabilitation of partially or severely damaged facilities, as well as risk reduction and resilience measures is estimated at 14 million euro.
- Housing:** A total of 11,490 housing units were categorised as fully destroyed or demolished and need to be rebuilt. An additional 83,745 of housing units were either partially or lightly damaged, needing repair and refitting. Overall, 18% of total housing units have been affected. The total effects are valued at 696 million euro, whereas recovery and reconstruction are estimated at 803 million euro over the short, medium and long term.
- Infrastructure:** Of the total damage and loss in this sector, which amounts to 33 million EUR, one-third was in the municipality of Durrës. Government buildings and community infrastructure were particularly affected. There was damage to two river embankments, 50 gabion baskets, one dam, 42 municipal buildings, one prison, and 33 office buildings. The total losses of all sub-sectors amount to 3 million euro. The overall needs for reconstruction and recovery were estimated at 61 million euro.
- Productive:** The total effects estimated for the sector are 150 million euro. The Tourism sub-sector sustained the most damage and losses with 90 million euro, the majority of which is due to losses from an expected decline in foreign visitors between 2020 and 2022. The Business & Employment sub-sector is the second most affected with 53 million euro in damage

and losses, most of it on account of the damage sustained by 714 businesses in manufacturing and trade. In the Cultural Heritage sub-sector, two national museums and three local museums were classified as insecure and are still closed to the public, while an additional 23 monuments and sites were classified as high risk and another 30 monuments as medium risk. Damages in the Agriculture sub-sector were minor and relate to agricultural inputs and equipment. There was also damage to embankments and water drainage stations in Durrës and Lezhë, as well as to the Institute for Food Safety and Veterinary building. The recovery needs in this sector amount to 51.83 million euro, over half is in the Business and Employment sub-sector with 27.84 million euro, followed by tourism with 10.88 million euro.

- **Social Protection:** damages are not reported under this sector, as it is included either under community infrastructure or public buildings in the Infrastructure sector. Losses mainly refer to governance, coordination, and disaster management as well as referrals, psycho-social counselling and social care services that are estimated at 624 thousand euro, whereby 1/3 are public and 2/3 are private. The total needs of the sector are estimated at 2.8 million euro.
- **Civil Protection and Disaster Risk Reduction:** 57 buildings from the Ministry of Defence were damaged, one firefighting station had to be demolished, two buildings of the Albanian Geological Survey were partially damaged, eight monitoring stations from the IGEWE were slightly damaged, six buildings from the General Directorate of State Reserves were slightly damaged as well, and seven additional buildings were damaged beyond repair. The damages were estimated at 8.8 million euro and 13 million euro for losses. The total needs for the sector reconstruction and recovery were estimated at 48 million euro.

5.3 Macroeconomic impact

The PDNA report [5.5] estimated that the earthquake has caused effects that are equivalent to 6.4% of 2018 gross domestic product (GDP) in damages and to 1.1% of GDP in losses. Damages amount to 26.4% of gross fixed capital formation indicating a limited capacity of Albania to achieve full reconstruction in a short to medium time. The damage and loss assessment estimates show that tourism and real estate activities have been the hardest hit by the earthquake; and significant damages have been inflicted on education, health, manufacturing and trade. On the other hand, the reconstruction and recovery efforts are expected to partially offset the negative effect on economic activity through a faster growth of the construction sector and to a lesser extent, trade and professional activities. The GDP growth impact estimation is based on the estimated production losses at sector level, accounting for smaller economic gains of other sectors. In nominal terms, GDP in 2020 is estimated to be lower by about 98 million euro. As a result of the earthquake, real GDP growth over 2019 and 2020 is estimated to be lower with effects of capacity loss constraining growth over the medium. As a result, the Albanian economy is projected to grow by an estimated 2.4% in 2019 and a 3.2% in 2020 from a pre-earthquake baseline estimated growth of 2.9% and 3.5% respectively [5.5].

The earthquake has caused significant economic losses in some key sectors, especially in housing and other buildings, accommodation and food (tourism), education, health, manufacturing. The share of real estate activities in Albania's economy is 5% of GDP. The earthquake losses in real estate activities are due to disrupted rental activities and owner-occupied dwelling in damaged and severely damaged residential property. The total effects (damages and losses) are valued at 696 million euro, with the total damages amounting to 662 million euro and the total losses estimated at 34 million. As a result of the earthquake the sector is estimated to decline by 0.4% in 2020, from a baseline of an expansion of 2.7% [5.5].

Accommodation and food service activities account for 2.3% of Albania's economy. Fuelled by expanding tourism, the sector has seen an increase of 10% on average over the last 4 years and has aided lowering the current account deficit. The earthquake damaged several structures including small informal facilities. Beside debris removal estimated losses also include these related to loss in employment and cancelled reservations from tourists. As a result, the sector is contracting by 9.1% in 2020 from a pre-earthquake baseline of an 8% growth. Together with the real estate activities losses in accommodation and food services, account for almost the entire decline in real GDP growth in 2020 with respect to the pre earthquake baseline [5.5].

Manufacturing, which accounts for 6.6% of GDP, is projected to grow by 0.1 percent points less compared to the baseline, with losses accounting for loss in jobs up to 4.45 months, debris removal and interruption of production activities [5.5].

Damages in health, education transport and utilities and infrastructure such as government buildings, roads hospitals and schools have also been damaged significantly. The total damage and losses have caused problems for the service delivery of the affected communities, thus contributing to the decline in GDP. Education, which accounts for 4% in GDP, is projected to increase by 5.2%, 1.2 percent points lower than the pre earthquake estimate. Human health and social work activities sector is projected to increase by 5% compared to pre-earthquake projections of 5.6%. The loss in these sectors arises from larger operational expenses related to debris removal, emergency repairs, costs of reallocating essential services in other areas, etc. [5.5]

On the other hand, earthquake emergency responses and reconstruction efforts are expected to modestly offset the decline in the economy by contributing to higher growth in the construction sector and related services including transport trade and professional activities in 2020. Under a reconstruction and recovery scenario, the construction sector, which accounts for 9.4% of GDP, is expected to grow over several consecutive years [5.5].

The earthquake is also expected to put further strains on public finances: the fiscal deficit is estimated to be higher by 0.7 percentage points of GDP. Trade deficit and the current account deficit (CAD) are expected to worsen as well. CAD is expected to widen by about 0.2% of GDP, increasing from a pre-earthquake baseline projection of 7.1% to 7.3% of GDP in 2020 [5.5].

All estimations made in the PDNA report [5.5] and reported above were made before the 2020 Covid-19 pandemic in Europe, so at the time of writing the current report the projection might have substantially changed in an unfavourable direction due to the unpredictable situation faced by Albanian and international economy.

5.4 Socio-economic impact

The PDNA report [5.5] provides an assessment also on the impact of the earthquake at household level. To evaluate the impact on poverty and human development, the PDNA used the results of the 'Survey of Household Damages due to Earthquake' (SHDE) undertaken by United Nations Development Program (UNDP) and Albanian Institute of Statistics (INSTAT) during December 2019 in three regions, was applied in the seven most affected municipalities out of 11. The affected municipalities from the earthquake were: Tirana, Durrës, Kamza, Krujë, Kurbin, Shijak, and Vora. The main indicators measured through this survey were the movement of persons due to the earthquake, persons at-risk-of-poverty, severe material deprivation, subjective poverty and housing conditions.

SHDE estimated that 9.2% of the population in the affected areas moved out of their usual place of living, whereas 26.9% of them have not returned during the period of the interviews [5.5].

Subjective poverty based on self-assessment of the household in seven municipalities was estimated at 11.9% before the earthquake, and it is raised to 14.2% after it [5.5].

The comparison of those at-risk-of-poverty rates after the earthquake among municipalities indicates that the highest value of relative poverty is recorded in Kurbin (52.9%) followed by Kamza (39.2%). The lowest at-risk-of-poverty rate is recorded in Durrës (8.7%), followed by Shijak (15.4%). In general, the number of persons estimated at-risk-of-poverty has increased across municipalities, except in Tirana, where the concentration of multi-floor buildings constructed after 1993, characteristic for the urban area, is higher [5.5].

The percentage of the population with an enforced lack of at least four out of nine material deprivation items, severe material deprivation rate before the earthquake, in seven municipalities in 2018 was estimated at 33.2%. While SHDE showed that the severe material deprivation went up to 41.6%, the highest rate of severe material deprivation before the disaster was recorded in Kamza (47.4%) and the lowest in Vora (8.5%) and Kurbin (8.6%) [5.5]. The survey results showed that after the disaster, severe material deprivation rate increased on average by 8.4 per cent points, or 25.4%, compared to before. The highest differences are recorded in Vora 56 p.p., and Kurbin about 49 p.p. A considerable difference of 17.8 p.p. is recorded in Durrës, reflecting an increase of 137% compared to 2018. Krujë is the only district that recorded a decrease in this period (Figure 5.11).

In total, in the affected areas, 14% of the households have planned to pay costs to repair damages caused by the earthquake, where 38.8% of them can afford to pay through their own sources. On average, a household plans to pay 1,590 euro for repair works [5.5]

The earthquake had a significant impact on self-perception of people's mental health following the traumatic event. About 42.9% of the population after the earthquake have problems related to emotional exhaustion or trouble with sleeping, depression, or anxiety. About 5.6% of the affected population considered themselves to have difficulties in seeing, hearing, walking or climbing, or remembering and concentrating after the earthquake [5.5].

Figure 5.11 Severe material deprivation in the affected areas

Municipalities	Before earthquake	After earthquake	After – Before	
	Percentage	Percentage	p.p. ⁵²	Percentage
Durres	13.0	30.8	17.8	137.0
Kamza	47.4	49.9	2.6	5.4
Kruja	35.7	25.2	-10.5	-29.5
Kurbin	8.6	57.5	48.9	568.2
Shijak	25.0	30.5	5.5	21.8
Tirana	39.3	43.3	4.0	10.2
Vora	8.5	64.5	56.0	659.5
Total	33.2	41.6	8.4	25.4

Source: Table 40 from the PDNA report [5.5]

5.5 Post-disaster response

The earthquake caused 51 fatalities, of which seven were children age 0-14 years, 34 were between the ages of 15-59, and 10 were over the age of 60. Overall, 24 women and 27 men lost their lives. At least 913 people were injured, including 255 people who were injured during the aftershocks. First responders rescued ten people, and 38 people were rescued by Albanian and international Urban Search and Rescue (USAR) teams [5.5].

As a result of the earthquake, a total of 202,291 people were affected in the country, of whom 47,265 were directly affected, and 155,028 were indirectly affected. According to the Head of Emergency, as of 30th December, there were 10,225 displaced people accommodated in 12 shelter locations, 3,613 in hotels and an unknown number privately hosted. A total of 7,286 families so far were registered as qualifying for the rent bonus program. More than 900 wounded persons were been treated in hospitals, and as of 15th January, only one patient remains at the trauma hospital. More than 21,000 children, which constitute 7% of all students in the 11 affected municipalities, were relocated to host-schools [5.5].

The Government of Albania (GoA) decreed a State of Emergency on 27th November for Durrës and Tirana prefectures and the day after for Lezhë, resulting in the establishment of the Inter-Ministerial Committee of Civil Emergency. They prepared a detailed work program to cope with the situation created by the earthquake. Authorities moved swiftly to respond with search and rescue (SAR) operations and humanitarian aid. Firefighters, civil protection, medical emergency personnel, the Armed Forces and State Reserve were immediately deployed for the initial life-saving phase. Albania deployed a total of 7,600 responders, including 534 volunteers and 278 specially trained Army USAR personnel [5.5].

The GoA has an existing, efficient, and well-practiced procedure for requesting international assistance and therefore activated the European Civil Protection Mechanism (EUCPM) on 26th November. The Albanian first responders were supported by 541 emergency personnel from twelve EU countries and 304 personnel from eight non-EU countries [5.5].

The international community supported the GoA with humanitarian supplies and institutional support. An EU Civil Protection EUCP Team was deployed to Albania on 27th November. The United Nations (UN) mobilized a UN Disaster Assessment and Coordination (UNDAC) team for the humanitarian phase and worked in coordination with the EUCP Team and the Albanian government on conducting a building damage assessment. The WB undertook a GRADE [5.1] that gave a preliminary estimate of the scope and magnitude of the disaster. Once the most immediate humanitarian phase was over, the GoA requested support from the EU the UN, and the WB to undertake a full and comprehensive PDNA to identify the damage, losses and recovery needs arising from the event.

5.6 Casualty-causing buildings

The Mw6.4 earthquake that struck Albania on 26th November caused 51 deaths and wounded 913 people. Collapses of 9 buildings caused 47 fatalities and four people died in circumstances caused by the earthquake. One victim had a heart attack during the shaking, another had a car accident, while the third one jumped out of his balcony in panic, and the last victim died due to bricks falling from above while trying to reach safety. A description of the buildings that caused fatalities is presented in Figure 5.12 to Figure 5.19:

- Figure 5.12: Four-storey RC building in Durrës that caused 8 fatalities. Four-storey RC building in Durrës which caused 8 fatalities. a) the building in 2016 prior to the earthquake [5.16], b)

the building after the main shock [5.20], and c) Final configuration [5.15] of the collapsed building. The building was constructed without permission from the authorities according to [5.9].

- Figure 5.13: Six-storey RC building in Durrës, built in 1996 that caused 7 fatalities. Six-storey RC building in Durrës, built in 1996 that caused 7 fatalities. a) & b) The building before and after the earthquake [5.8], [5.1]. It is reported that the building might have been built without a proper design [5.9].
- Figure 5.14. Five-storey RC building in Durrës, a hotel dedicated to the employees of the Internal Ministry, in Durrës that caused 1 fatality. a) & b) the hotel before and after the earthquake [5.17], [5.22].
- Figure 5.15. Six-storey hotel in Durrës, that caused 2 fatalities, at least the first five stories are RC, that caused 2 victims. a) and b) the hotel before and after the earthquake [5.11]. The hotel was built without permission from the authorities, according to [5.9] and [5.14].
- Figure 5.16: Five-storey RC hotel in Durrës that caused 2 fatalities. Five-storey RC hotel in Durrës that caused 2 fatalities. a) and b) the hotel before the earthquake [5.18], [5.19]. First the hotel was built with 2 stories, later three more stories were added without permission from the authorities [5.9].
- Figure 5.17. Eight-storey RC hotel in Durrës that caused 1 fatality. a) and b) the hotel before and after the earthquake [5.10], [5.7]. First the building had three stories, later on upon permission from the authorities three more stories were added [5.9]. Last two stories were built without permission from the authorities [5.25].
- Figure 5.18. Six-storey RC building that caused 2 fatalities. [5.9][5.13] a) and b) the building before and after the earthquake [5.13], [5.26].
- Figure 5.19. Two five-storey calcium-silicate masonry buildings in Kodër-Thumanë that caused 24 fatalities [5.12], [5.21]. a) It is reported that in the building 16 people died under the debris and one was wounded and died in a car accident while was being transported to a hospital. b) It is reported that in this building 8 people died under the debris [5.24], [5.23]. The buildings were constructed pre 1990 with voluntary work [5.9], and likely with improper knowledge of construction and inferior material quality.

The presented photos are mostly taken from publicly available sources (before photos) and national and local media outlet (after photos) as referred in the figure captions.

Figure 5.12: Four-storey RC building in Durrës that caused 8 fatalities



Figure 5.13: Six-storey RC building in Durrës, built in 1996 that caused 7 fatalities



Figure 5.14: Five-storey RC building in Durrës, a hotel dedicated to the employees of the Internal Ministry, in Durrës that caused 1 fatality

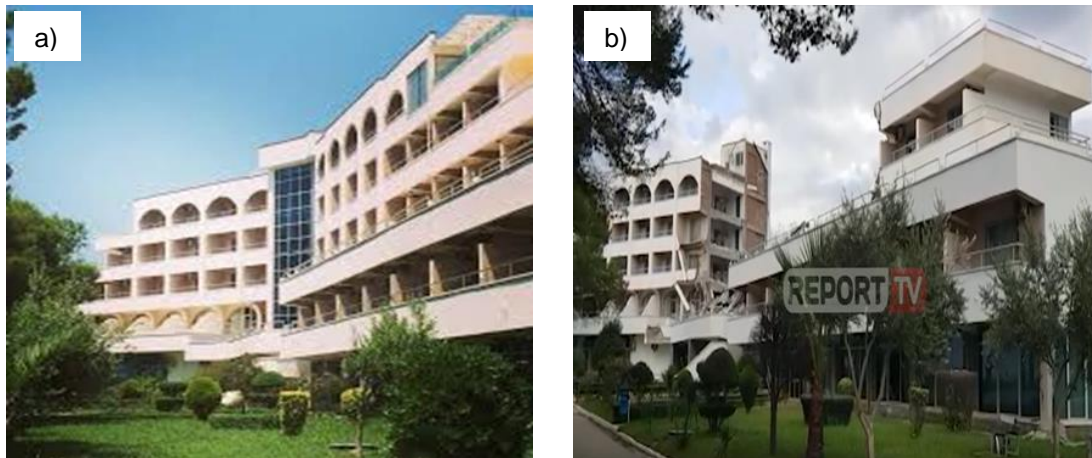

Figure 5.15: Six-storey hotel in Durrës, that caused 2 fatalities, at least the first five stories are RC, that caused 2 casualties

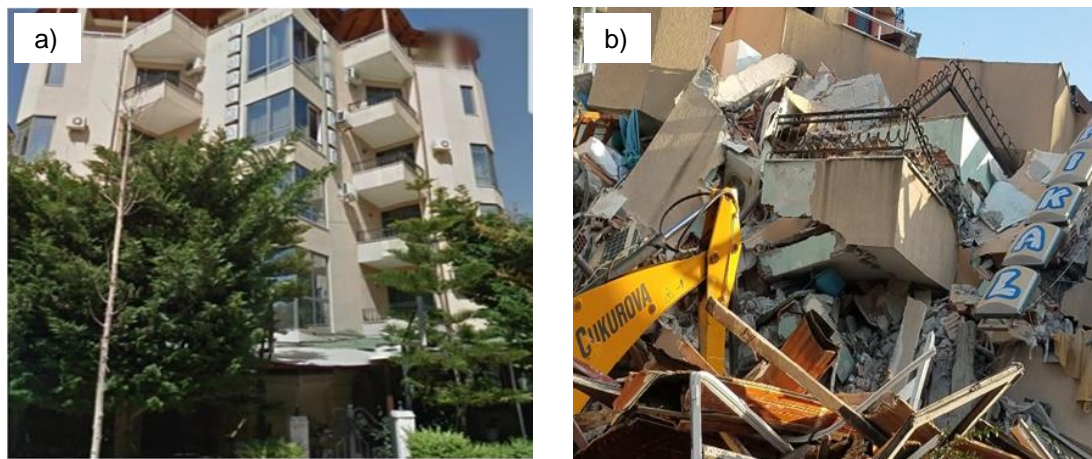

Figure 5.16: Five-storey RC hotel in Durrës that caused 2 fatalities

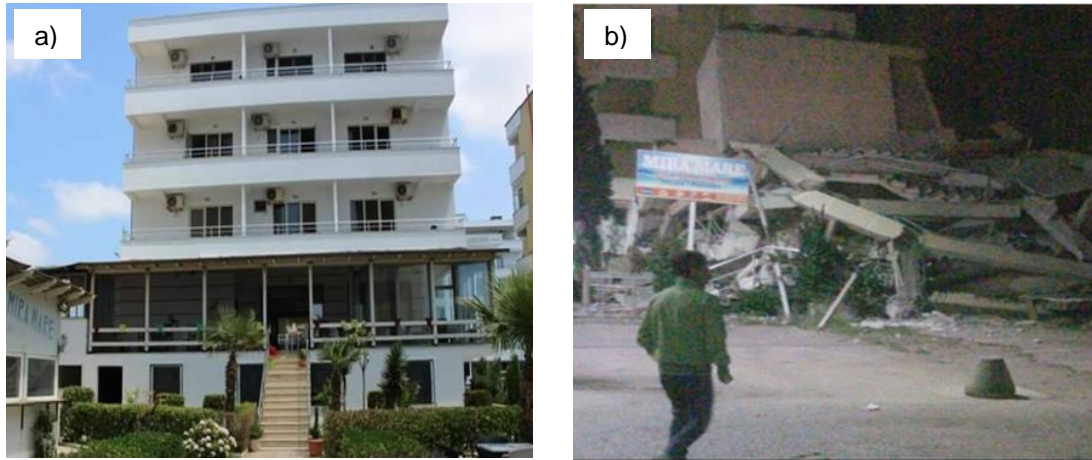

Figure 5.17: Eight-storey RC hotel in Durrës that caused 1 fatality



Figure 5.18: Six-storey RC building that caused 2 fatalities

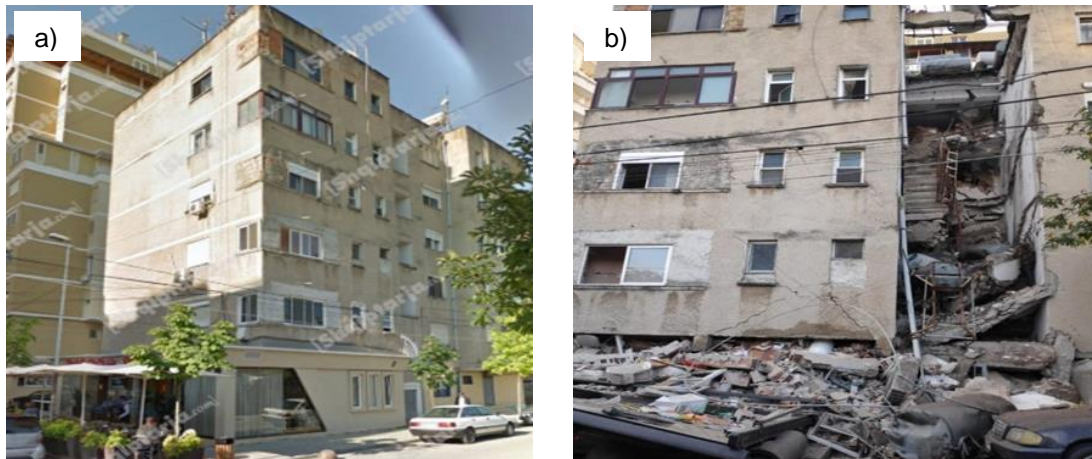

Figure 5.19: Two five-storey calcium-silicate masonry buildings in Kodër-Thumanë that caused 24 fatalities



5.7 References for chapter 5

- [5.1] EMSC, (2019), “M6.4 ALBANIA on November 26th 2019 at 02:54 UTC”, retrieved from <https://www.emsc-csem.org/Earthquake/262/M6-4-ALBANIA-on-November-26th-2019-at-02-54-UTC>
- [5.2] USGS, (2019), “M 6.4 - 15km WSW of Mamurras, Albania”, retrieved from <https://earthquake.usgs.gov/earthquakes/eventpage/us70006d0m/executive>
- [5.3] IGEWE, (2019), “Strong motion records from the 26th November 2019 Durrësi earthquake”, dataset retrieved from <https://www.geo.edu.al/newweb/?fq=november>, Instituti i Gjeoshkencave, Energjise, Ujit dhe Mjedisit, Tirana
- [5.4] The World Bank GPURL D-RAS Team, (2019), “M 6.4 Albania Earthquake Global Rapid Post Disaster Damage Estimation (GRADE) Report”, retrieved from https://www.humanitarianresponse.info/sites/www.humanitarianresponse.info/files/assessments/2019-12-16_grade_alb_eq_nov2019_final.pdf
- [5.5] Republic of Albania Council of Ministers, The European Union, The United Nations Albania, The World Bank, (2020), “Albania Post-Disaster Needs Assessment Report”, retrieved from https://ec.europa.eu/neighbourhood-enlargement/sites/near/files/albania_post-disaster_recovery_a_v9.0.pdf.
- [5.6] Durrës/ Mbyllet operacioni i kërkimit shpëtimit tek godina pranë Kryqit të Kuq. (2019, November 28). GAZETA SHQIPTARE. Retrieved from <http://www.gsh.al/2019/11/28/durres-mbyllet-operacioni-kerkim-shpetimit-tek-godina-prane-kryqit-te-kuq/>
- [5.7] FOTO/ Shembja e hotelit I morri jetën të atit dhe I biri ngeli nën rrënoja, arrestohen pronarët e “Vila Palmës”. (2019, December 14). Shqip. Retrieved from <https://www.gazeta-shqip.com/2019/12/14/foto-shembja-e-hotelit-i-mori-jeten-te-atit-dhe-i-biri-ngeli-nen-rrenoja-arrestohen-pronaret-e-vila-palmes/#img=2>
- [5.8] Foto/ Zbulohen imazhet, ja si ishte më pare pallati 6 katësh që morri 7 jetë njerëzore. (2019, December 6). Syri.net. Retrieved from <https://www.syri.net/kronike/299668/zbulohen-imazhet-ja-si-ishte-me-pare-pallati-6-katesh-qe-mori-7-jete-njerezore/>
- [5.9] INVESTIGIMI/ Historiku I 10 pallatave të mallkuara që u shembën dhe zunë nën rrënoja banorët Durrës dhe Thumanë. (2019, November 28). Shqiptarja.com.

- Retrieved from <https://shqiptarja.com/lajm/historiku-i-pallateve-qe-u-shemben-dhe-zune-nen-rrenoja-banoret-ne-durres-dhe-thumane>
- [5.10] Kështu dukej Vila Palma para se të shkatërrohej nga tërmeti. (2019, November 26) Gazeta Infocus. Retrieved from <https://gazetainfokus.com/keshtu-dukej-vila-palma-para-se-te-shkaterrohej-nga-termeti/>
- [5.11] Nën gërmadha ende të bllokuar dy kosovarë! Si ishte dhe si u rrafshua nga tërmeti hotel 'Tropical' në Durrës. (2019, November 26). Shqiptarja.com. Retrieved from <https://shqiptarja.com/lajm/nen-germadha-ende-te-blokuar-dy-kosovare-si-ishte-dhe-si-u-rrafshua-nga-termeti-hotel-tropikal-ne-durres>
- [5.12] "Pallati në Thumanë ishte shpallur I pabanueshëm, Prokuroria duhet të kishte nisur hetimet". (2019, November 26). fakteplus. Retrieved from <https://fakteplus.net/pallati-ne-thumane-ishte-shpallur-i-pabanueshem-prokuroria-duhet-te-kishte-nisur-hetimet/>
- [5.13] Pronarët I hoqën kolonat e katit të pare të pallatit për të hapur verandën e kafenesë... tragjedia që mund të ishte shmangur te 'Dy Gjelat' në Durrës. (2019, November 28). Shqiptarja.com. Retrieved from <https://shqiptarja.com/lajm/iu-hoqen-kollonat-e-katiti-te-pare-per-ta-bere-kafenetragedia-qe-mund-te-ishte-shmangur-te-dy-gjelat-ne-durres?r=pop5h>
- [5.14] Pronari i Hotel Tropikal e mori lejen në bashki pasi ndërtoi. (2019, December 16). Opinion.al. Retrieved from <https://opinion.al/pronari-i-hotel-tropikal-e-mori-lejen-ne-bashki-pasi-ndertoi/>
- [5.15] Shembet vila në zonën e Kënetës në Durrës, nuk dihet fati I njerëzve. (2019, November 26). lajmi.net. Retrieved from <https://lajmi.net/shembet-vila-ne-zonen-e-kenetes-ne-durres-nuk-dihet-fati-i-njerezve/>
- [5.16] 'Shkopinjte' që mbanin në këmbë vilën 4 katëshe... Si ishte ndërtuar godina nën rrënojat e së cilës u shuan 8 familjarë! (2019, November 29). Shqiptarja.com. Retrieved from <https://shqiptarja.com/lajm/shkopinjte-qe-mbanin-ne-kembe-vilen-4-kateshesi-ishte-ndertuar-godina-nen-rrenojat-e-se-ciles-u-shuan-8-familjare-fotot>
- [5.17] Shtëpia Pushimit MPB-Kavalishenca. (2015, January 16). [Photograph]. Retrieved from <https://www.facebook.com/shtepiapushimitMPB/photos/d41d8cd9/1562055344037706/>
- [5.18] Hotel Bar-Restorant "Mira Mare" (2018, June 25). [Photograph]. Retrieved from <https://www.facebook.com/miramare.durres/photos/pb.641426702597240.2207520000./2131151983624697/?type=3&theater>
- [5.19] F. G. (2019, November 26). Nga rrënojat e Hotel "Mira Mare", nxirret e pajetë ballerina e lokalit të tallavasë, kishte pak muaj që punonte në Durrës. dosja.al. Retrieved from <https://dosja.al/nga-rrenojat-e-hotel-miramare-nxirret-e-pajete-balerina-e-lokalit-te-tallavase-kishte-pak-muaj-qe-punonte-ne-durres/>
- [5.20] J. V. (2019, November 26). Tragjeida e familjes Lala në Kënetë të Durrësit/ Dalin emrat, cilët janë viktimat dhe sa gjenden nën rrënoja. dosja.al. Retrieved from <https://dosja.al/tragjedia-e-familjes-lala-ne-kenete-te-durresit-dalin-emrat-cilet-jane-viktimat-dhe-sa-gjenden-nen-rrenoja/>
- [5.21] Karaj V. (2019, November 28). Mort dhe mosbesim: Thumana vajton viktimat e 'tragjedisë së paralajmëruar'. Reporter.al. Retrieved from <https://www.reporter.al/mort-dhe-mosbesim-thumana-vajton-viktimat-e-tragjedise-se-paralajmruar/>
- [5.22] Report TV. (2019, November 28). Komisari vdiq në gjumë në mesin 10 vjecare, 112 studentë shpëtuan në pjesën e Konvaleshencës [Video file]. Retrieved from https://www.youtube.com/watch?v=CQQK3G2XD_8
- [5.23] ABC News Albania. (2019, December 3). Speciale/ U prene ne bese! E verteta e rrezimit te pallateve ne Thumane| ABC News Albania [Video file]. Retrieved from https://www.youtube.com/watch?v=9cJEy5tr5cE&feature=emb_err_watch_on_yt

- [5.24] Top Channel Albania. (2019, December 3). Top Story - "Pabesia" - Pamje dhe rrëfime të patransmetuara, për 51 viktimat e tërmetit [Video file]. Retrieved from <https://www.youtube.com/watch?v=DUEPWpGVoaU>
- [5.25] Në kërkim pronarët e 'Vila Palma' në Durrës. (2019, December 14). Mapo. Retrieved from <https://gazetamapo.al/lajmi-i-fundit-arrestohen-pronaret-e-vila-palma-ne-durres/>
- [5.26] Zhyten në tokë dy katet e para të pallatit në Durrës, dyshohet për viktima në rrënoja. (2019, November 26). NEWSBOMB. Retrieved from <https://www.newsbomb.al/zhyten-nen-toke-dy-katet-e-para-te-pallatit-ne-durres-dyshohet-per-viktima-ne-rrenoja-187296>

6 Damage assessment of the investigated buildings

Several damage assessment forms have been used in the past EEFIT missions. Although some of the information collected was the same for the different missions, forms have been adapted every time to be able to reflect the type of assessment conducted. EEFIT missions over time have demonstrated the singularity of each post-disaster scenario and therefore the need of an *ad hoc* planning of each mission.

6.1 Approach to damage assessment

In some missions, such as EEFIT's 2016 mission to Ecuador following the M_w 7.8 Muisne Earthquake, the extent of the damage in the city was best captured by a rapid visual assessment with less than 5 min spent per building; in others, the reduced extent of the damage, the lack of accessibility and other factors resulted in a more detailed assessment of a reduced number of buildings [6.1]. Therefore, the type of the information collected was quite different and reflected in the form adopted. The damage assessment of the structures affected by the November 2019 earthquake was undertaken collecting the information provided in Table 6.1, which was shaped around the specific needs of this mission, such as accessibility and typology of building stock to assess, time availability, and locations [6.2].

Table 6.1: List of collected information











Collected information	
Building identifier	Age of Construction
Person recording	Structural System
Hour inspection	Facade
Date	Extension
Location	Date of Extension
Lat	Typology of Roof
Long	Typology of Floor
Occupancy	EMS 98 damage grade
Access	Structural performance level (ASCE 41)
Current occupation state	Failure mechanism
Number of floors	Comments
Basement	

In recent times, the interest of the professional community moved towards the adoption of digitalized forms, which facilitate the standardization of the recording, postprocessing and the velocity of the assessment. Different tools are available to build customizable assessment forms, which among other information allow the recording of the pictures and GPS location. During this mission, the information was stored directly on an excel file from the mobile phone and uploaded on the server at the end of each field day. Also, the team decided to experiment the use of two apps for damage assessment to be able to provide feedbacks to the developers. The damage assessment apps were respectively provided by EEFIT and the University of Bristol.

To optimise the time and due to the geographic distance of the affected areas, sub-teams were formed to inspect a larger number of buildings at the same time. Each team was provided with a camera, a GPS localiser, and the database spreadsheet (accessible via smartphone).

The European Macro-seismic Scale (EMS-98) [6.3] was adopted to define the damage state of the Albanian building stock. As shown in Figure 6.1, five damage levels classifications (from DS1 to DS5) for masonry buildings and RC buildings in addition to the no damage state (DS0) make up the damage scale. A description of each damage level is provided in Figure 6.1.

Figure 6.1: Damage level classification based on EMS-98

Damage Degree	Description of Damages (examples)	
	Masonry	Reinforced Concrete
0	Absence of damage	
1		Fine cracks in plaster over frame members or in walls at the base. Fine cracks in partitions and infills. 
2		Cracks in columns and beams of frames and in structural walls. Cracks in partition and infill walls; fall of brittle cladding and plaster. Falling mortar from the joints of wall panels. 
3		Cracks in columns and beam columns, joints of frames at the base and at joints of coupled walls. Chipping of concrete cover, buckling of reinforced rods. Large cracks in partition and infill walls, failure of individual infill panels. 
4		Large cracks in structural elements with compression, failure of concrete and fracture of rebars; bond failure of beam reinforced bars; tilting of columns. Collapse of a few columns or of a single upper floor. 
5		Collapse of ground floor or parts (e.g. wings) of buildings. 

Source: European macroseismic scale EMS-98 [6.3]

In addition to the EMS damage classification, the team catalogued the buildings based on the ASCE41 performance levels [6.4]. This scale is widely used in the engineering community to define the acceptance performance criteria for the design of buildings and does not intend to describe the damage of a building after an earthquake. A performance level is assigned to each building to identify its performance level achieved after the earthquake. Of the five levels in the scale (S-1 to S-5), the team considered S-1, S-3, S-5, and > S-5 only, as these result to be more discrete and well separated, and thus facilitate the correlation with the damage state of the building due to an earthquake. Figure 6.2: ASCE41-17 performance levels provides a description of each performance level in ASCE41-17.

Figure 6.2: ASCE41-17 performance levels

<p>Immediate Occupancy Structural Performance Level (S-1)</p>	<p>Structural Performance Level S-1, Immediate Occupancy, means the post-earthquake damage state in which only very limited structural damage has occurred. The basic vertical- and lateral-force-resisting systems of the building retain almost all of their pre-earthquake strength and stiffness. The risk of life-threatening injury as a result of structural damage is very low, and although some minor structural repairs might be appropriate, these repairs would generally not be required before reoccupancy. Continued use of the building is not limited by its structural condition but might be limited by damage or disruption to nonstructural elements of the building, furnishings, or equipment and availability of external utility services.</p>
<p>Life Safety Structural Performance Level (S-3)</p>	<p>Structural Performance Level S-3, Life Safety, means the post-earthquake damage state in which significant damage to the structure has occurred but some margin against either partial or total structural collapse remains. Some structural elements and components are severely damaged, but this damage has not resulted in large falling debris hazards, either inside or outside the building. Injuries might occur during the earthquake; however, the overall risk of life-threatening injury as a result of structural damage is expected to be low. It should be possible to repair the structure; however, for economic reasons, this repair might not be practical. Although the damaged structure is not an imminent collapse risk, it would be prudent to implement structural repairs or install temporary bracing before reoccupancy.</p>
<p>Collapse Prevention Structural Performance Level (S-5)</p>	<p>Structural Performance Level S-5, Collapse Prevention, means the post-earthquake damage state in which the building is on the verge of partial or total collapse. Substantial damage to the structure has occurred, potentially including significant degradation in the stiffness and strength of the lateral-force-resisting system, large permanent lateral deformation of the structure, and—to a more limited extent—degradation in vertical-load-carrying capacity. However, all significant components of the gravity-load-resisting system must continue to carry their gravity loads. Significant risk of injury caused by falling hazards from structural debris might exist. The structure might not be technically practical to repair and is not safe for reoccupancy because aftershock activity could induce collapse.</p>
<p>>S-5 Collapse</p>	

S-1 Immediate Occupancy	Only very limited structural damage has occurred. The basic vertical- and lateral-force-resisting systems of the building retain almost all of their pre-earthquake strength and stiffness. The risk of life-threatening injury as a result of structural damage is very low, and although some minor structural repairs might be appropriate, these repairs would generally not be required before re-occupancy. Continued use of the building is not limited by its structural condition but might be limited by damage or disruption to nonstructural elements of the building, furnishings, or equipment and availability of external utility services.
S-3 Life Safety	Significant damage to the structure has occurred but some margin against either partial or total structural collapse remains. Some structural elements and components are severely damaged, but this damage has not resulted in large falling debris hazards, either inside or outside the building. Injuries might occur during the earthquake; however, the overall risk of life-threatening injury as a result of structural damage is expected to be low. It should be possible to repair the structure; however, for economic reasons, this repair might not be practical. Although the damaged structure is not an imminent collapse risk, it would be prudent to implement structural repairs or install temporary bracing before re-occupancy.
S-5 Collapse Prevention	The building is on the verge of partial or total collapse. Substantial damage to the structure has occurred, potentially including significant degradation in the stiffness and strength of the lateral-force-resisting system, large permanent lateral deformation of the structure, and-to a more limited extent-degradation in vertical-load-carrying capacity. However, all significant components of the gravity-load resisting system must continue to carry their gravity loads. Significant risk of injury caused by falling hazards from structural debris might exist. The structure might not be technically practical to repair and is not safe for re-occupancy because aftershock activity could induce collapse.
>S-5 Collapse	The building does not meet the requirements of S-5 collapse prevention performance level.

Source: ASCE41-17 [6.4]

6.2 Summary of investigated buildings

During the four days of field mission, a total of 70 structures were inspected (Figure 6.3). 26% of the buildings were partially accessed, whereas the rest of the buildings were inspected from the outside only. Apart from the largely affected areas of Durrës and Durrës beach, the team visited other affected districts such as Bubq, Prezë, Laç, Lezhë, Krujë, and Thumanë. In the city of Durres the buildings to be inspected have been selected based on the information received on the affected areas. In fact, not all neighbourhood have been affected by the earthquake the same way and small damage clusters were clearly visible in some areas due to the particular vulnerability of the type of construction present. The methodology adopted to capture the largest number of building was to subdivide the team in two groups, with each group walking along the main roads of different affected neighbourhoods, recording its significant buildings.

Multiple building typologies were identified, of which the most common are RC frames (without any core wall or with a small core) and load bearing masonry, which make up approximately 65% and 30% of the inspected building portfolio. Other identified building typologies include precast RC panel and the confined masonry buildings.

The occupancy of the vast majority of the inspected buildings (70%), damaged by the earthquake, and visited during this mission is residential. A limited number of public buildings were visited such as schools, hospital, and fire brigades. The mission included some cultural heritage sites that have also been significantly damaged by the November earthquake, including several towers, religious buildings, and fortification walls. One bridge was also included in the mission, representing the only infrastructure assessed.

Figure 6.3: Example of summarised information collected during the mission: access; location; construction typology; and use of the inspected building

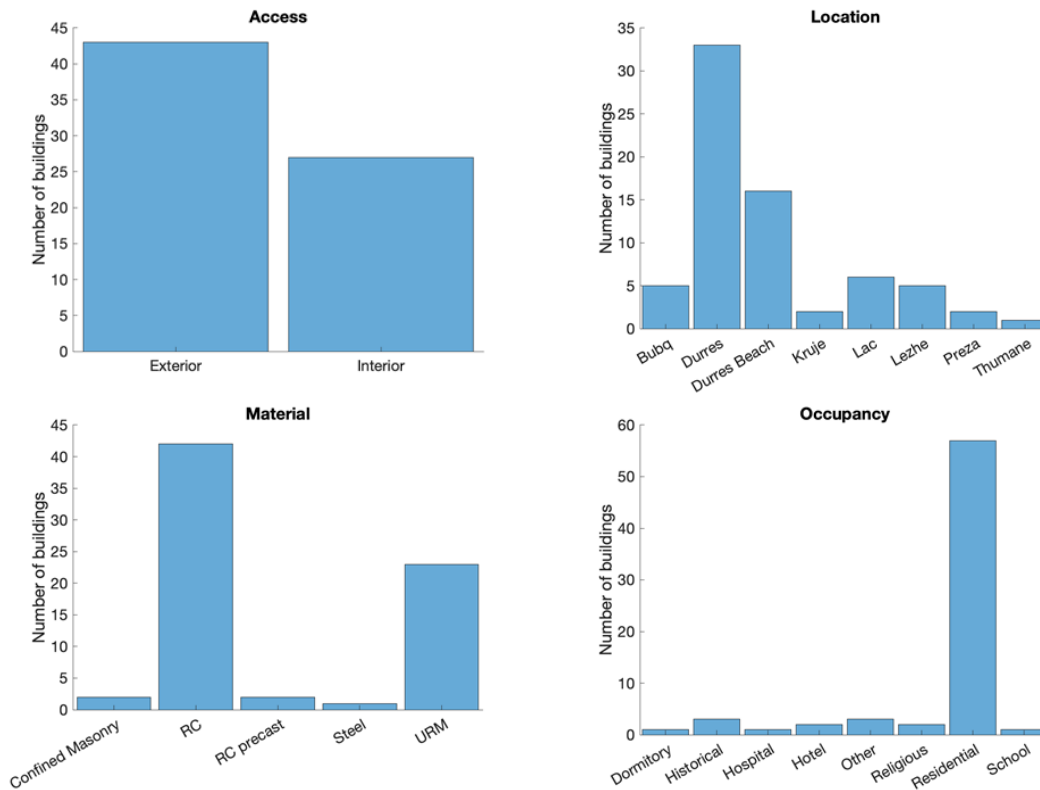

Summary histograms of the database collected during the field mission are shown in Figure 6.4. The unreinforced masonry buildings are characterised by a maximum of five storeys. As expected, most of these buildings were built before the 1960s or between 1960 and 1990. About 10 of the inspected masonry buildings were assigned a damage state DS4 due to the serious structural failure observed on the masonry walls and slabs. Therefore, most of the buildings were found unable to meet the requirements of S-5 collapse prevention performance level.

RC buildings vary between 2- and 12-storeys, with 10-storeys buildings being the most frequent among those inspected. Approximately 30 of the inspected RC buildings have been built after the 2000s, and less than 10 buildings have been built between the 1980s and 1990s.

The vast majority of the RC building was assigned damage state DS3, mainly due to the cracks in partitions and infill walls, with often failure of individual infill panels.

Many 5-storey large panel buildings and some confined masonry structures were identified in Durrës and the other districts, some of which have been visited during the field mission. The age of construction of these structures is likely to be around the 1980s. All the large panel buildings (RC precast in the figures) have shown a damage state up to to DS1.

The locations of the investigated buildings and the assigned EMS-98 damage grades are shown in Figure 6.5 to Figure 6.9 (maps made with QGIS with OSM base maps).

Figure 6.4: Field mission database summary filtered by construction typology: number of stories; year of construction; performance level (ASCE41); Damage Grade (EMS-98)

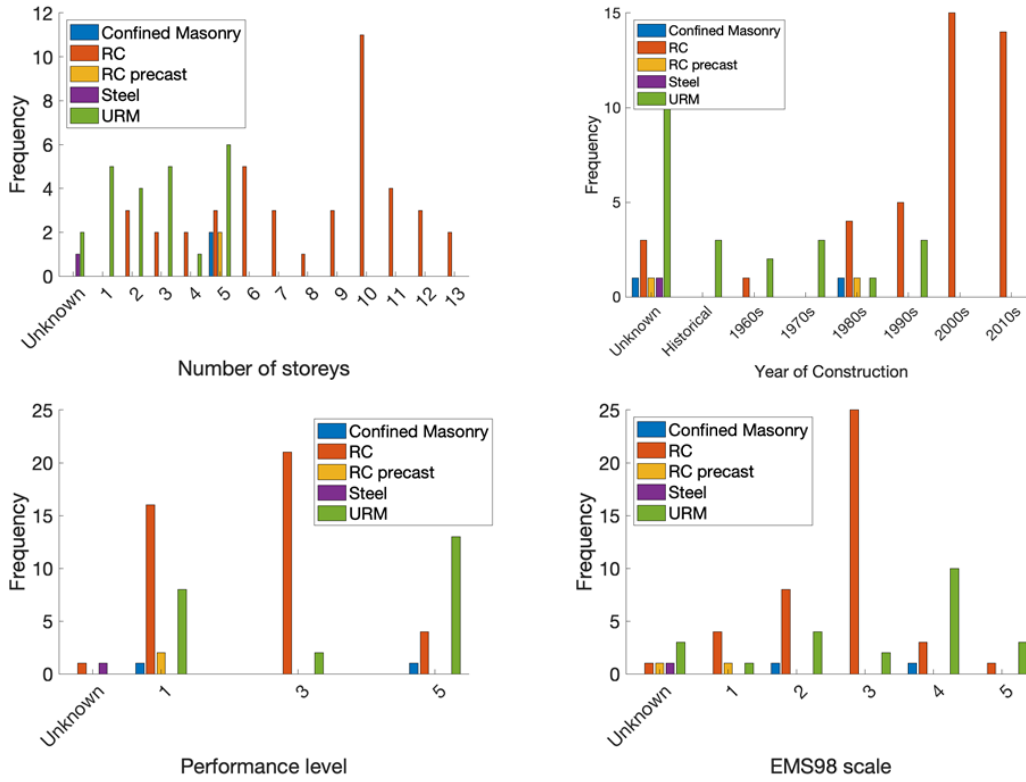

Figure 6.5: Inspected buildings and assigned EMS-98 damage grades: Durrës city



Figure 6.6: Inspected buildings and assigned EMS-98 damage grades: Durrës beach area

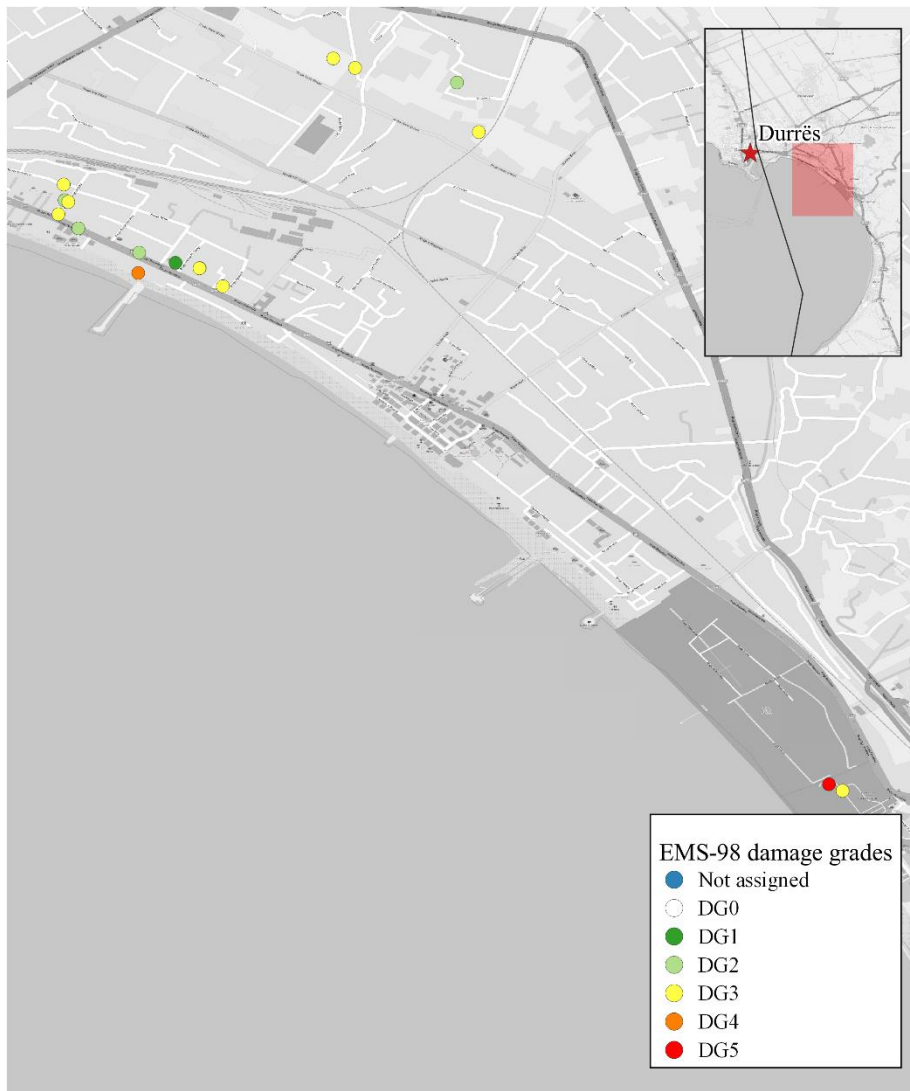

Figure 6.7: Inspected buildings and assigned EMS-98 damage grades: Laç

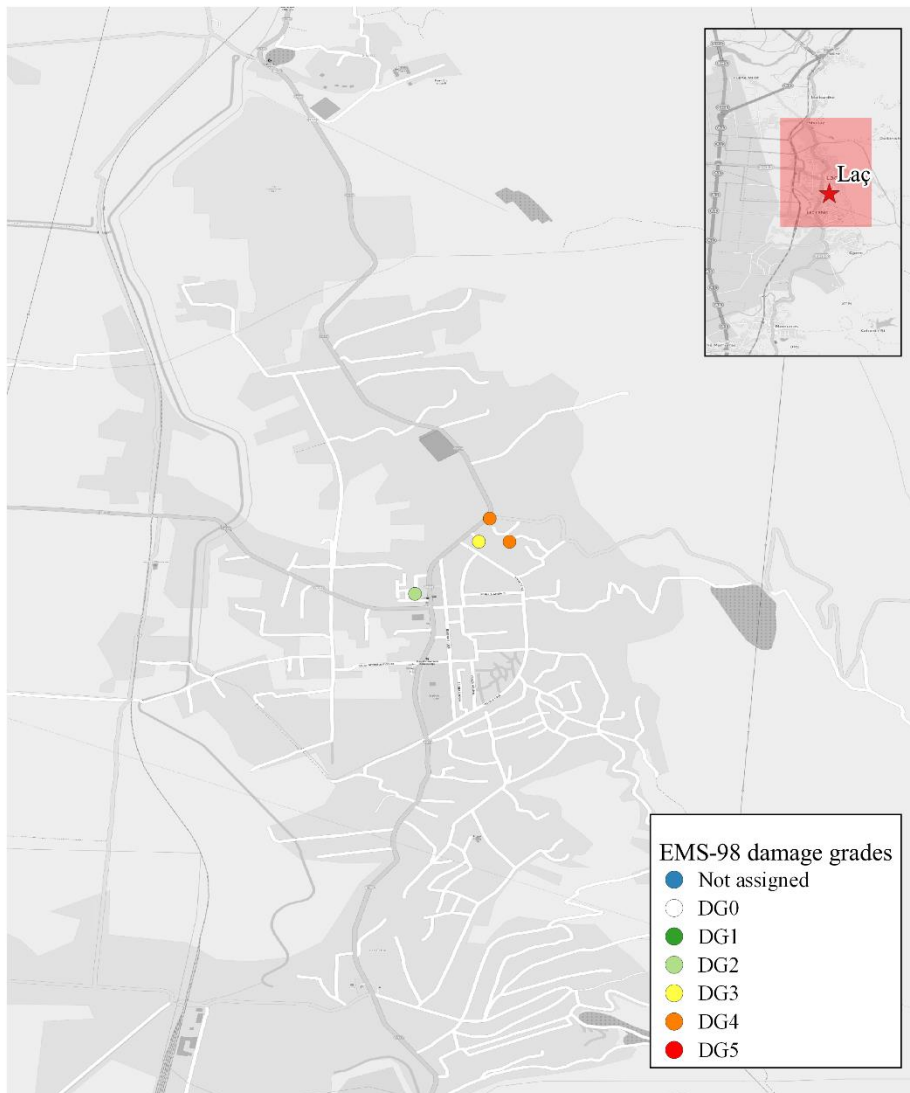

Figure 6.8: Inspected buildings and assigned EMS-98 damage grades: Lezhë

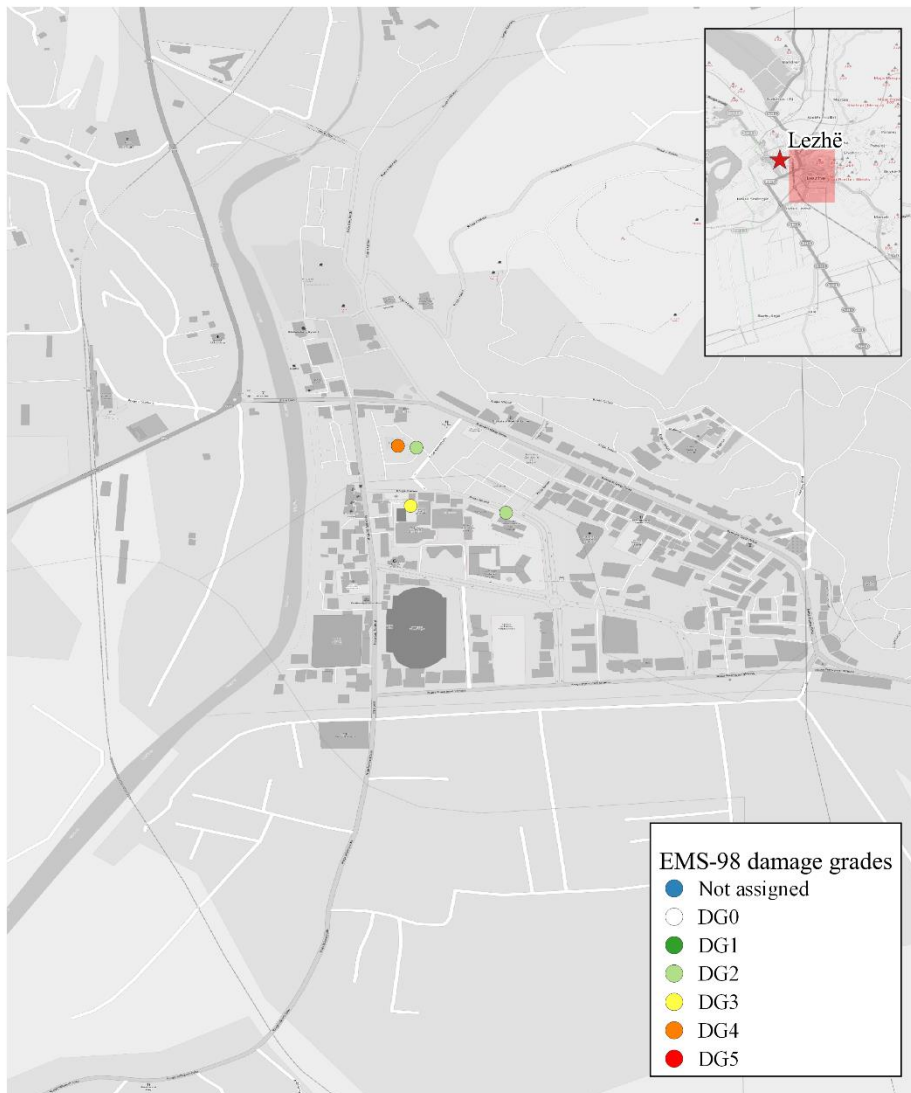
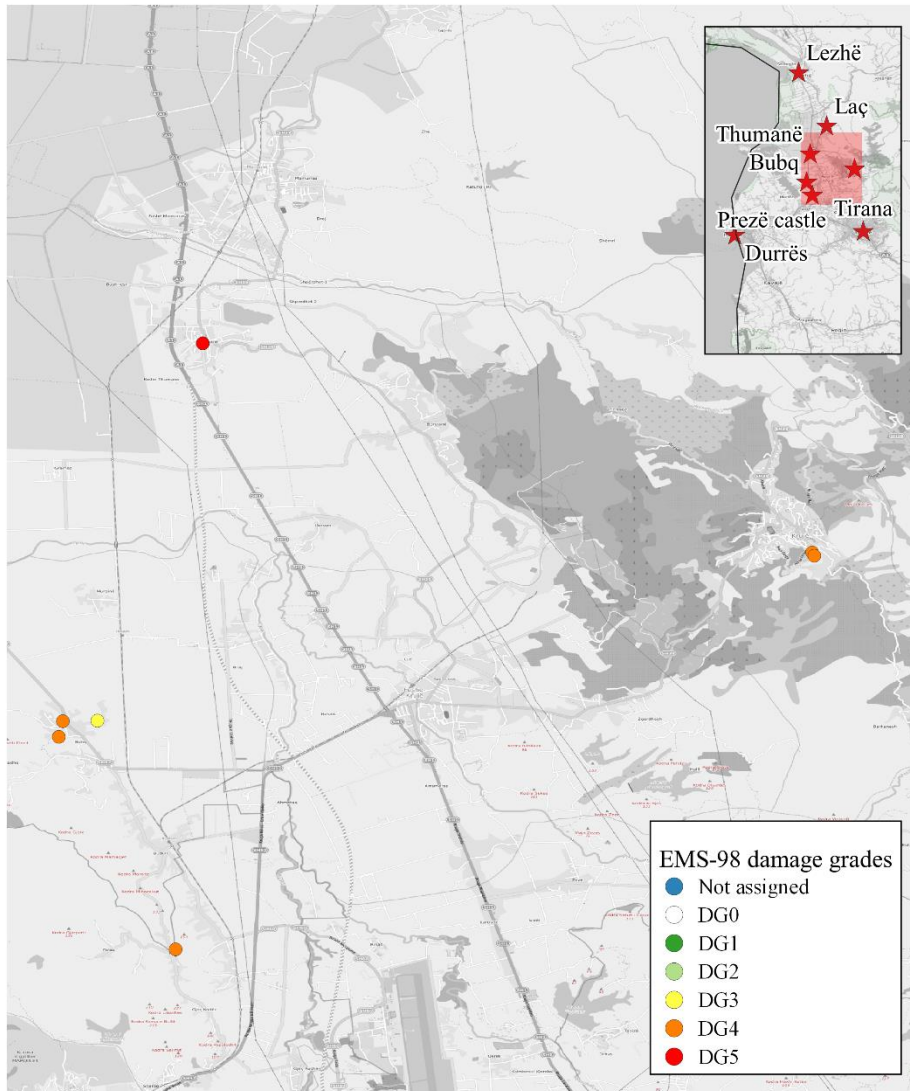

Figure 6.9: Inspected buildings and assigned EMS-98 damage grades: Bubq, Thumanë, Krujë castle and Prezhë castle



6.3 References for chapter 6

- [6.1] Stone, H., Putrino, V., & D’Ayala, D. (2018). “Earthquake damage data collection using omnidirectional imagery,” *Frontiers in Built Environment*, 4 (51).
- [6.2] Putrino, V., & D’Ayala, D. (2018), Cumulative damage assessment and strengthening efficacy of masonry buildings in Norcia affected by the 2016 seismic events in Central Italy, EEFIT, University College London
- [6.3] Grünthal G (editor), (1998), *European Macroseismic Scale 1998*, Luxembourg
- [6.4] ASCE41-17 (2017), “*Seismic Evaluation and Retrofit of Existing Buildings*”, American Society of Civil Engineers

7 Case studies

This section describes the observed damage to both recent and historical buildings through several representative case studies. The aim is illustrating the characteristic damage patterns observed in the main structural typologies of the Albanian building stock. These observations try to highlight possible links between the typical damage patterns and the deficiencies in construction practices and/or the use of inappropriate retrofit techniques. Since extensive damage was observed on modern buildings, this also allows identifying some likely gaps of the current seismic design code and possible areas of development.

7.1 Pre-1990 unreinforced masonry buildings

In Albania, unreinforced masonry (URM) buildings were widely used for residential and public purposes between 1944 and 1990. These buildings were built according to standardised templates approved by the Albanian governmental authorities [7.5] proposing cost-effective layout for URM constructions from two to five stories. Two main codes were adopted for the design of these typology: KTP-9-78 [7.3] for gravitational loads, and KTP-N.2-78 [7.2], for seismic loads [7.5]. Nowadays, these buildings are still in used and signify a high percentage in the residential stock of the country [7.5].

The buildings of 3- and 5-storey height in Figure 7.1 and Figure 7.2 are representative of this typology for their geometric plan, material types, and structural features. Typical floor height is 2.8 m, and openings have regular layout. Concrete lintels over the openings are commonly used to transfer gravitational loads. Bearing walls have thickness of 250 mm and 380 mm for buildings of 3- and 5-storey height respectively, while partition walls have thickness of 120 mm. Masonry walls are made of solid fired clay bricks with dimensions 250×125×60 mm or silicate bricks with dimensions 250×125×65 mm. Bricks are bonded using cement or silicate mortar. Two main floor systems are adopted: concrete slabs and hollow core precast concrete panels.

Figure 7.1: a) Standard template of a 3-storey URM building Original plan can be found at [7.4] [08], b) typical 3-storey URM building in Thumanë, Albania

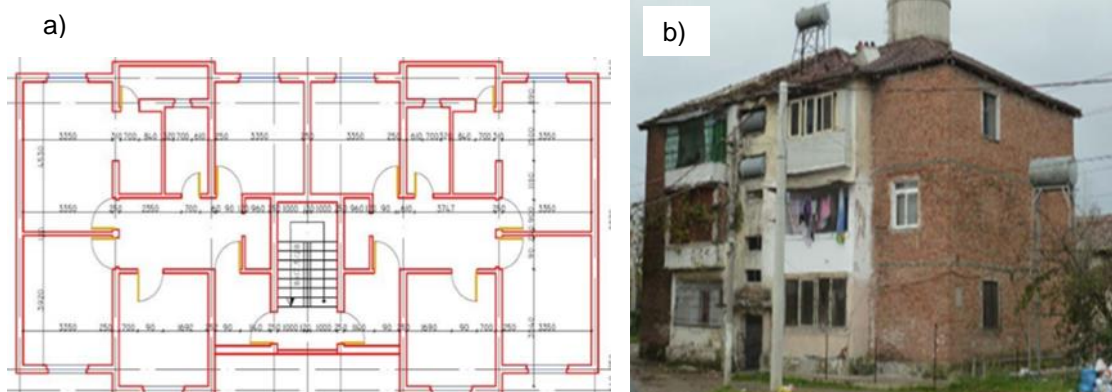

Figure 7.2: a) Standard template of a 5-storey URM building. Original plan can be found at [7.4], b) typical 5-storey URM building in Thumanë, Albania

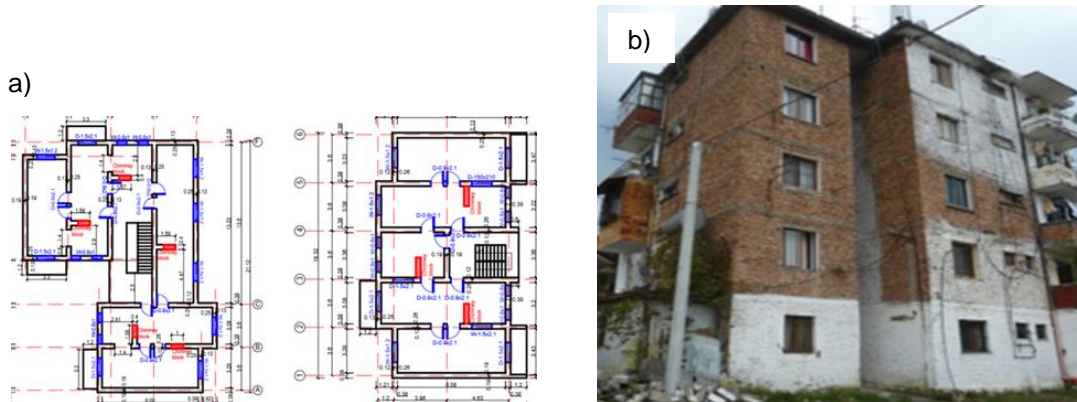

Figure 7.3: Typical bricks for URM buildings. Solid clay bricks with a) silicate mortar; b) cement mortar; c) silicate bricks with silicate mortar



Buildings in fired clay bricks and cement mortar with concrete slabs show a good seismic performance, as illustrated in Figure 7.4, pictures taken in the city centre of Durrës, one of the worst affected cities by the earthquake due to failures and severe damage observed on RC buildings. The good connections observed among bearing walls and the presence of RC slabs working as a diaphragm under seismic loads underline the effectiveness of the design templates for URM buildings standardised by the Albanian governmental authorities in the Communist period. The major deficiencies observed for these buildings are related to irregularities in elevations due to unauthorised interventions (e.g., additional floors, closure and creation of new openings, use of different masonry for reparation) of Figure 7.5, carried out by local residents. These interventions together with the lack of maintenance observed for this typology, by degrading mechanical properties of the constructional material and changing load paths, may become the cause of possible damage and collapse, if an earthquake of high intensity hits these areas in the future.

Figure 7.4: Typical 5-storey URM buildings in Durrës



Figure 7.5: Irregularities in elevations due to unauthorised interventions on URM buildings in Durrës



The only pre-1990 URM buildings which collapsed during the seismic event in November 2019 were made of solid silicate bricks and hollow core precast concrete slabs. These were located in Thumanë, see Figure 7.6. This was one of the most damaged towns, where a total number of 24 deaths were registered due to the collapse of two buildings of this typology (one 3-storey and two 5-storey buildings). The causes of collapse for these buildings are associated with the poor mechanical properties of the silicate bricks and the lack of connections between the precast concrete slabs and the bearing walls failing in overturning.

Inspections in Thumanë were carried out after the buildings were already demolished, therefore information related to these failures were provided by local engineers.

Figure 7.6: a) Collapsed 5-storey URM building in Thumanë; b) view from the air of the collapsed building in Thumanë; c) destruction in the town of Thumanë, one of the worst affected areas



Buildings made of silicate bricks with hollow core precast concrete slabs were also inspected in the city of Lezhë, located in the northwest of Albania, about 50 km from the epicentre. In this area, damage to the buildings was not considered severe, and was only observed in a few cases. The 5-storey building in Figure 7.7, representative of the typical pre-1990 URM structures inspected in this area, was built in built in 1974. The building was tagged “red” as unsafe by local engineers, although no damage was observed on external bearing walls and only light cracks were detected on internal bearing walls. The damage observed by internal inspection consists of shear diagonal and X-shape cracks on bearing walls, and horizontal cracks on ceilings highlighting a displacement in the prefabricated panels in the slabs.

Figure 7.7: a) 5-storey pre-1990 URM buildings made of silicate bricks and hollow core precast concrete slabs, inspected in Lezhë (red tagged by local engineers), b) typical light shear cracks observed on internal bearing walls

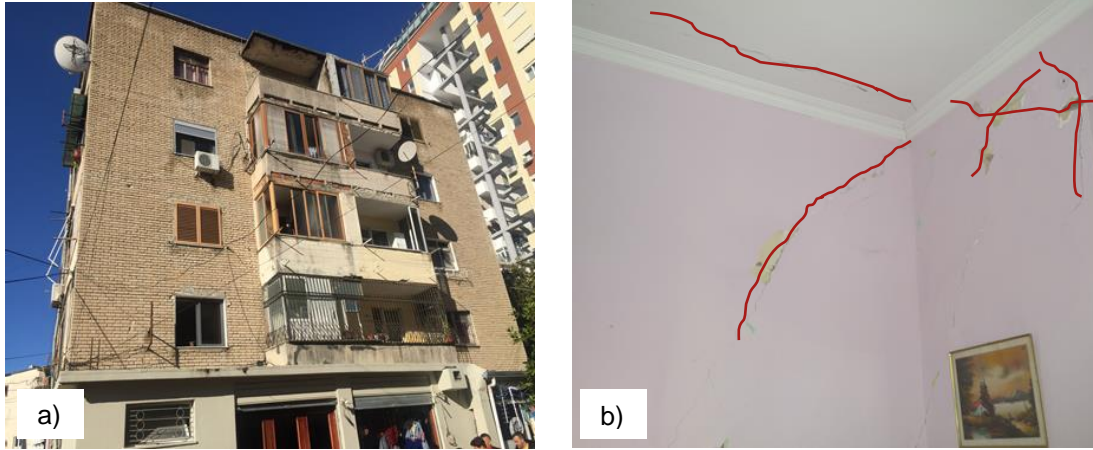

More severe damage was observed on silicate brick buildings with hollow core precast concrete slabs which had undergone to large interventions carried out with an inadequate seismic design. Figure 7.8 reports the damage due to the extension of the 5-storey building built in 1974 (see green plan in Figure 7.8a) with a 4-storey building from RC built in 1980 (see red plan in Figure 7.8a). The different stiffness the URM and RC buildings caused severe pounding damage visible on the external bearing walls (Figure 7.8b), the cracks along the opened gap between buildings observed during the internal inspection (Figure 7.8c), and the detachment of the staircase due to torsion (Figure 7.8d).

Figure 7.8: a) 5-storey pre-1990 URM buildings made of silicate bricks and hollow core precast concrete slabs, inspected in Lezhë (red tagged by local engineers), b) pounding damage between the URM building and RC building, c) gap opening, and d) detachment of the staircase

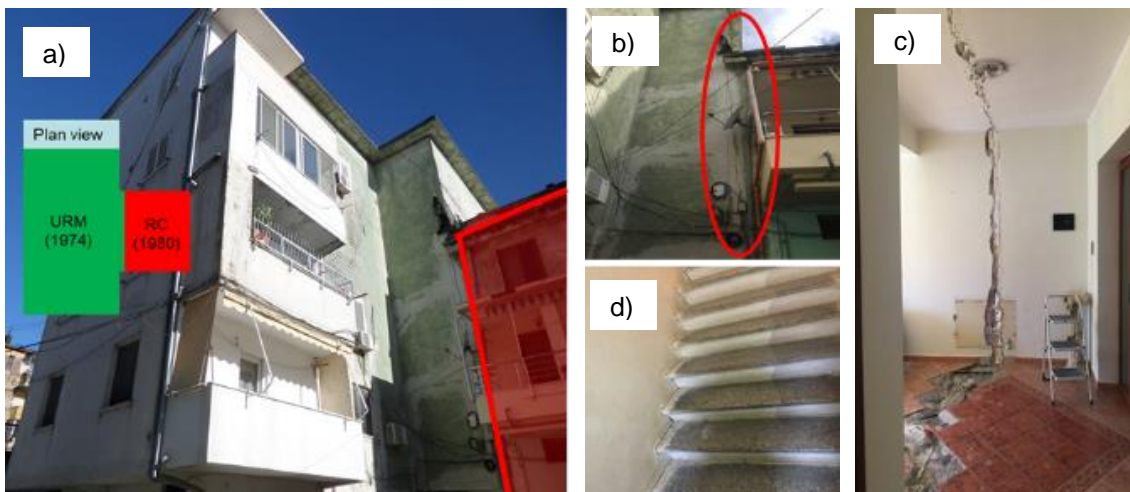

7.2 Pre-1990 prefabricated large-panel buildings

As many other countries in Eastern Europe, in the 1960-1970s Albania responded to the growing demand for new houses utilising the emerging trends for industrialization of the construction process and mass construction of prefabricated residential buildings. While in most other eastern European countries this technology was imported from the Soviet Union, the large-panel buildings in Albania were based on construction technologies from China, which on the other hand was based on Soviet model, aiming at building large residential complexes in a short time through precast RC elements. In the early years after the war, several studies were carried out in order to develop useful and especially cheap type of projects to host single families. In 1972, the Ministry of Construction approved the model design developed by The Institute of Design Studies No. 1 (IDS No. 1) [7.7]. During the 1970s large-panel buildings spread throughout the country and became the main type of construction in the Albanian cities such as Shkodër, Tirana, Durrës, Lushnjë, Burrel, Elbasan, Berat, Pogradeci, Laç, Lezhë, Korçë, Tepelenë, Gjirokastër [7.7]. Basic information for the large-panel construction technology used in Albania is illustrated in Figure 7.9. As to the architectural layouts of precast large-panel buildings, there were four main planimetric modules: Module 1, Module 1a, Module 2 and Module 2a. In most cases the buildings have five or six storeys and comprise different modules, the number of which depended on the urban project [7.7]. The floor plans of the modules and some typical configurations of LPBs in Albania are shown in Figure 7.10

Figure 7.9: Main structural characteristics of LPBs in Albania: a) panel types; b) 3D view of LPB construction sequence; c) panels before assembly; based on [7.7]

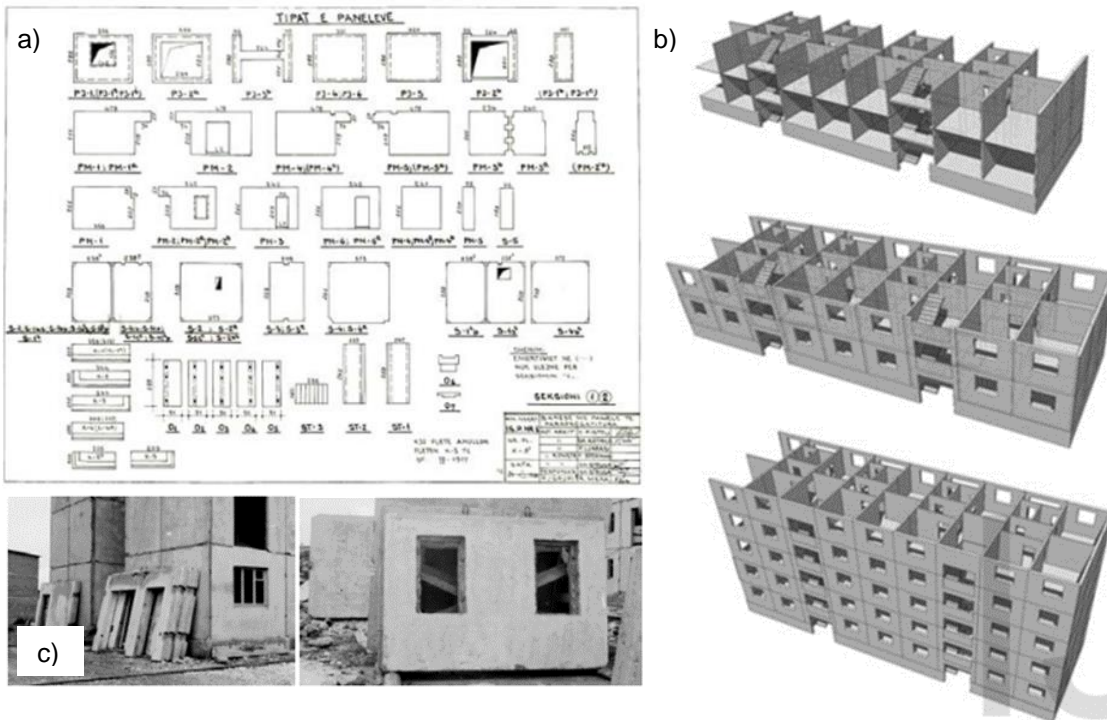
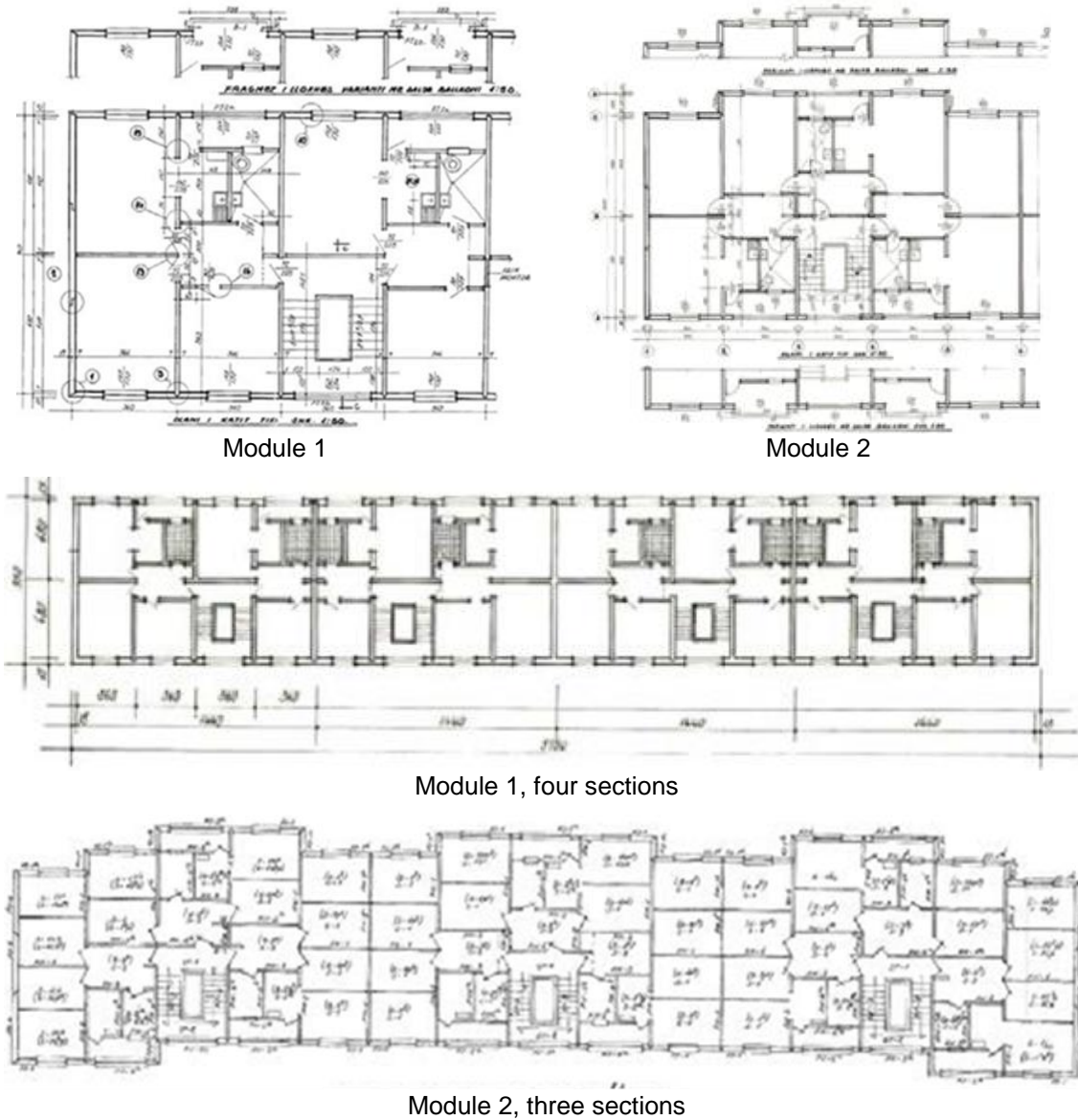

Figure 7.10: Typical floor plans and configurations of large-panel buildings in Albania [7.7]



Under earthquake loading the prefabricated wall should behave as one structural unit composed of interacting wall elements, see Figure 7.11. This structural interaction within the wall needs to be secured by structural connections that resist the required shear forces, tensile forces and compressive forces. If the strength of the horizontal and vertical joints exceeds the forces in the interface between the panels the prefabricated panel wall will have monolithic behaviour under lateral load, see Figure 7.12 a, and the structural damage will be concentrated in the form of diagonal cracks in the panels. However, in prefabricated concrete wall systems there may be significant slip (shear displacements) along the vertical and horizontal joints. Figure 7.12 b and c show horizontal actions applied to a large panel cantilever wall in which slip has occurred along both vertical and horizontal joints due to shear forces transferred along these joints. The effect of slip along the horizontal and vertical joints is to reduce the stiffness of the system. It is difficult to say which will be the prevailing seismic response and failure mode of large panel walls under earthquake loads. The observations in past earthquakes in Romania, Armenia and Bulgaria

suggest that slippage between panels is likely to occur since most of the reported damages were in the form of horizontal and vertical cracks in the interfaces between panels. It is also more logical to assume that the concrete quality and strength of the panels will be higher than this of the dowels due to the higher quality control of the prefabricated elements. However, the opposite configuration of “strong joints – weak panels” cannot be excluded. Slippage between panels is likely to be a source of significant friction damping and could be one of the reasons for the good seismic performance of large panel buildings observed in past earthquakes.

Figure 7.11: In-plane action of prefabricated wall, a) shear forces and b) tensile and compressive forces [7.20]

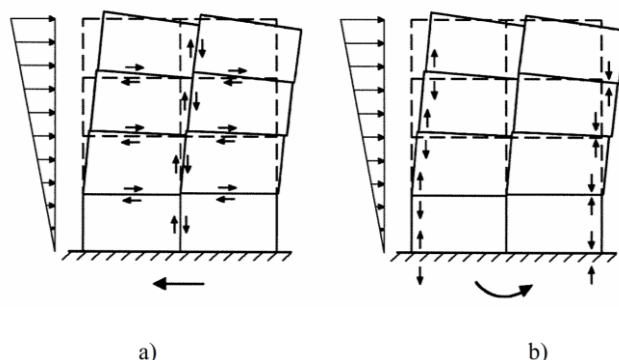
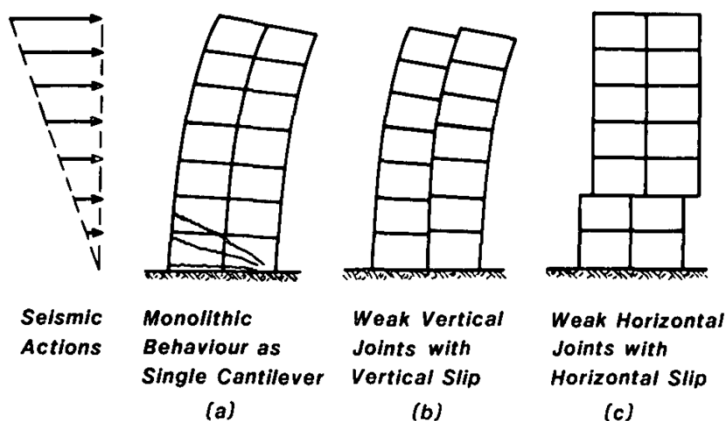

Figure 7.12: Behaviour of a large panel wall under lateral load – monolithic behaviour (a), vertical slip between panels (b) and horizontal slip (c) [7.21]



7.2.1 Observed seismic performance after the November 2019 earthquake

The team visited two neighbourhoods with large-panel buildings, in Laç on 14th December and in Durrës on 15th December. All buildings seemed to have poor maintenance and many signs of deterioration were visible on the facades, see Figure 7.13 and Figure 7.15. However, there were no external signs of earthquake-induced damage in any of the buildings. An inspection from inside showed minor cracking in the interface between the panels in the first two floors – vertical cracks in the contact zone between two wall panels, see Figure 7.14, and horizontal cracks in the contact zone between slab and wall panels, Figure 7.16. These are typical crack patterns in large-panel buildings in the onset of structural damage when the damage is mainly in the form of cracking of

the grouting between the panels and does not affect the structural safety. Cracks in the wall panels and damage in the dowels were not observed in any of the inspected large-panel buildings in Laç and Durrës.

Figure 7.13: Neighbourhood with LPBs in Laç (Module 1, two sections)



Figure 7.14: LPBs in Laç (Module 1, two sections): Vertical cracks formed in the interface between wall panels



Figure 7.15: Neighbourhood with LPBs in Durrës (Module 2 with one, two & three sections)



Figure 7.16: LPBs in Durrës (Module 2 with one, two & three sections): horizontal cracks formed in the interface between the wall panel and the floor panels



7.3 Multi-storey RC buildings

As discussed in section 4.2, The KTP-N.2-89 code [7.2] is currently enforced in Albania. However, for more recent designs, it became in fact common practice among structural engineers to use recommendations from the Eurocode to overcome the lack of detailed instructions in some parts of the Albanian code.

This part of the report focuses on two typologies of RC multi-storey buildings: 1) those designed during the 2000s, according to the Albanian KTP-N.2-89 code [7.2]; and 2) more recent buildings

(i.e., post-2010) designed according to KTP-N.2-89 while integrating aspects from Eurocode 8 [7.1]. Two case study buildings, both located in Durrës have been selected for these two typologies and are illustrated respectively in Figure 7.30a and b.

Figure 7.17: Example of typical RC multi-storey buildings. a) Typical 2000s building compliant with KTP-N.2-89; b) Typical post-2010 building compliant with KTP-N.2-89 with integration based on the Eurocode 8



Among the different RC building typologies that can be found in Albania, the focus on these typologies is justified by the following:

1. Relevance of these typologies, *i.e.*, many multi-storey RC buildings are present in the Albanian territory and in many of the areas significantly affected by the earthquake;
2. Consistent damage on such mid-rise structures while low-rise RC buildings experienced none or very small damage;
3. These buildings have been designed according to the design code and standards. Therefore, the observed damage allows a critical discussion of the code. This is not always the case with other types of low-rise RC structures that were designed outside the code or, in some cases, built by the owner even without a design;
4. These structures are characterised by some “unexpected” design features which make them different from typical multi-storey buildings located in other seismic areas in Europe.

The Albanian KTP-N.2-89 [7.2] code has been already illustrated and discussed in Section 4, however it is worth highlighting a few aspects that are relevant for RC multi-storey buildings. In particular:

1. The strength requirements of the Albanian code KTP-N.2-89 are lower than those of Eurocode 8 [7.1]. For most of the buildings surveyed by this team, they were not generally attained (based on visual inspections). Figure 7.18: a) Comparison of the elastic and design spectra for one representative site according to the KTP-N.2-89 [7.2] and Eurocode 8 [7.1]; b) belt beam for infill panels in typical post-2010 multi-storey RC buildings shows a comparison of the elastic and design spectra defined according to the

- KTP-N.2-89 and the Eurocode 8. The example refers to a structure located in an area with $PGA=0.36g$, soil category II, response factor $\psi=0.25$ (corresponding to a behaviour factor $q=4$ according to Eurocode 8) and a fundamental period $T_1=1.0\text{sec}$. In this case, the design spectral acceleration based on the KTP-N.2-89 is $S_a(T_1)=0.072g$ versus $S_a(T_1)=0.135g$ from Eurocode 8;
2. Ductility requirements are included in the Albanian code and, despite less detailed, are similar to those of modern seismic design codes. In fact, the KTP-N.2-89 requires: a) regularity checks, *e.g.*, uniformity of masses and stiffness, symmetry, simplicity, etc; b) ductile member detailing, *e.g.*, minimum longitudinal reinforcements, maximum stirrups spacing, etc; c) implicit capacity design, *e.g.*, strong columns-weak beams;
 3. Absence of stiffness requirements *i.e.*, no considerations regarding Damage Limit State (DLS) checks. This aspect could be considered the most evident difference between the KTP-N.2-89 and the Eurocode 8 and is the main one that, in this occasion, affected the seismic response of multi-storey RC buildings. This aspect shows that insufficient consideration is made to the damage of the building under low-intensity (*i.e.*, frequent) earthquakes, which is generally concentrated in the infill panels (for the considered building typology). However, attention is paid to the out-of-plane behaviour of the infills by the introduction of belt beams as shown in Figure 7.18: a) Comparison of the elastic and design spectra for one representative site according to the KTP-N.2-89 [7.2] and Eurocode 8 [7.1]; b) belt beam for infill panels in typical post-2010 multi-storey RC buildings.

Figure 7.18: a) Comparison of the elastic and design spectra for one representative site according to the KTP-N.2-89 [7.2] and Eurocode 8 [7.1]; b) belt beam for infill panels in typical post-2010 multi-storey RC buildings

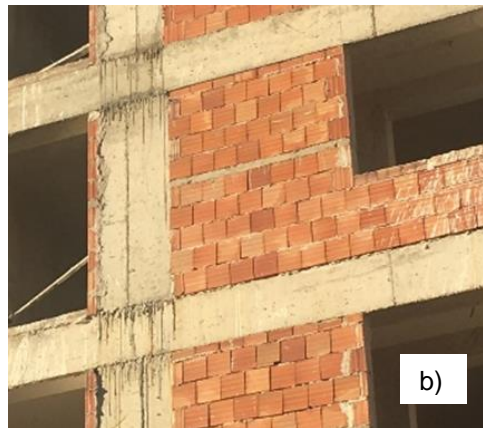
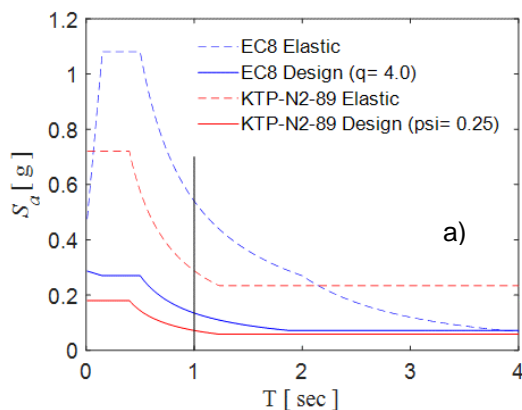

7.3.1 Typical 2000s multi-storey RC buildings

The first case study investigated is a typical 2000s multi-storey RC building located in Durrës just across Niko Dovana Stadium. Many buildings with similar characteristics showed the same damage pattern described here. The structure is characterised by nine storeys with a constant inter-storey height approximately equal to 3.20 m and by 5x4 bays with a constant span of ≈ 5 m. The structure is regular in plan and elevation and is illustrated in Figure 7.19a and b. Figure 7.19 shows the deduced indicative plan view. It is worth mentioning that, in this structure, no core wall is included and that the horizontal forces are resisted by the frames only. Based on the several observed buildings of this typology, this has been identified as a common situation where the

elevators RC core is absent. The building has shops at the ground level while the upper stories is for residential use.

Figure 7.19: Typical 2000s multi-storey RC building compliant with KTP-N.2-89: a) east façade; b) south façade; c) indicative plan view



The structure is characterised by internal and external columns with large dimensions approximately equal to 800x800 mm and 1100x3500 mm, respectively. The dimensions of the external column can be observed in Figure 7.20a, due to the formation of the vertical cracks in the plaster. Figure 7.20a shows also the cracks corresponding to the position of the beams which have a depth equal to the thickness of the floor slab and beam (approximately 300 mm). This structural configuration of strong columns-weak beams is most probably the outcome of low design accelerations and lack of stiffness requirements.

The infilled panels are made by large hollow bricks (250x250x200 mm), as shown in Figure 7.20b. The interaction of the flexible structure with the stiff infills led to significant non-structural damage. The infills are generally characterised by shear cracks. Moreover, some of the unconfined panels have collapsed, or experienced heavy damage. In addition, as shown in Figure 7.21, the damage pattern is also characterised by horizontal cracks at floor level in the lower side of the floor slabs. This is related to the lack of construction detailing and a poor connection between the top side of the infill panels and floor slabs. This configuration promotes the detachment of the infills from the beams. This damage pattern is distributed over the first five storeys of the building and it can be observed in Figure 7.22. Figure 7.23 shows a closeup of the damage pattern of the eastern façade of the building which highlights the significant vulnerability of this type of stiff infill panels, especially when unconfined.

Figure 7.20: Typical 2000s multi-storey RC building compliant with KTP-N.2-89: a) cracks in the plaster and identification of beams and columns; b) dimension of the hollow bricks for the infill panels

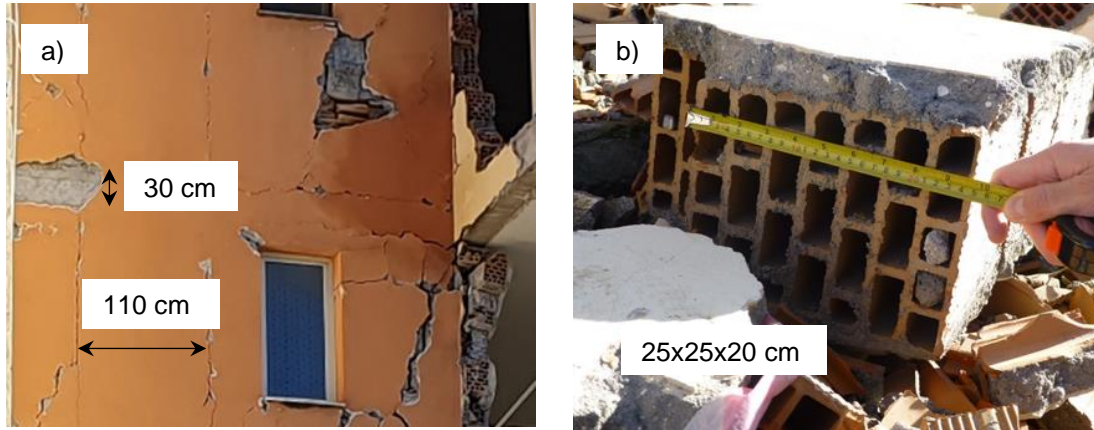

Figure 7.21: Typical 2000s multi-storey RC building compliant with KTP-N.2-89: a) collapse of the infill panel; b) detachment of the infill panel and formation of horizontal cracks



Figure 7.22: Typical 2000s multi-storey RC building compliant with KTP-N.2-89: damage layout on the eastern façade of the building



Figure 7.23: Typical 2000s multi-storey RC building compliant with KTP-N.2-89: damage layout on the eastern façade of the building, closeup



7.3.2 Typical post-2010 multi-storey RC buildings

The second case study investigated is a typical 2010+ multi-storey RC building located near Rruga Pavaresia, the main boulevard of the Durrës beach area. The structure is characterised by 10 storeys with a constant inter-storey height approximately equal to 3.20m, except for the first storey where the inter-storey height is about 4.00 m. The structure has 6.0m x 3.0m bays with variable spans ranging between 4.0. and 6.0 m. The columns of this building are particularly large (on the order of 800x800 mm), although direct measures were not possible. The structural frame itself is regular in plan and elevation and it is illustrated in Figure 7.24a and b. However, the presence of an eccentric core wall, in correspondence of the elevator, induces some irregularity the plan, as shown in Figure 7.24c. The observed damage pattern is consistent with this irregularity. The building is residential, but commercial activities are planned for the ground level. At the time of the survey, the building was still under construction. However, all the structural and the main non-structural components were completed.

This structure differs from the previous selected case study. Despite that KTP-N.2-89 code [7.2] is the current code enforced in Albania, most practitioners are now using the detailed formulations in Eurocode 8 [7.1] to implement the recommendations in the Albanian code (if the practical implementations are missing). For example, although the KTP-89 code requires that the columns must be stronger than the adjacent beams, it does not provide a quantitative formulation to perform this hierarchy of strength requirement. In this case, the detailed formulations provided in Eurocode 8 are adopted by practitioners. For example, it is likely that the detailing rules for beams and columns from Eurocode 8 are applied. It is worth mentioning that Eurocode 8 is not adopted in its entirety, *i.e.*, recommendations in the Eurocode 8 that are not also present in the KTP-N.2-89 are not applied. For example, it is unlikely that the damage limit state, displacement-based checks are applied. This insight is based on personal communication by local engineers.

In this building, damage was mostly concentrated in the staircase and in the interior infill panels. The damage of the stairs, exterior and interior, can be observed in Figure 7.25a and b respectively. This is likely related to the large displacements generated by the presence of the core wall, that induced torsional effects. Due to their higher stiffness, the staircase was not able to accommodate these displacements and experienced large shear cracks in the landings, in the external beams (including the adjacent non-structural walls). Extensive damage was observed in the first five stories of the structure.

As per the previous case study, the infilled panels are generally composed of large hollow bricks (250x250x200 mm). These bricks are used both for the external and the internal walls. Consistently with the previous case study, the interaction of the flexible structure with the stiff infills led to significant non-structural damage. This type of damage was higher in the internal partitions due to a lack of confinement and to the lack of interconnection between perpendicular infills. Figure 7.26a and b show the same corner of internal infills panels respectively at the 2nd and the 5th storey.

In addition, due to the torsional effects, also the external infills furthest from the core wall are damaged and characterised by shear cracks. This was better observed in the adjacent building (also under construction), with a geometry and characteristics identical to the one just described. In this case, it was not possible to access the building, but a similar damage pattern was observed externally. Also, in this case the damage pattern is related to the flexibility of the structure, torsional behaviour and use of stiff infill panels. The damage of the unconfined external partitions is shown in Figure 7.27. Clearly, the lack of confinement significantly affected the seismic response of the non-structural components, leading to shear cracks but also to out of plane failure of the infills. This is also highlighted in Figure 7.28, showing how the belt beams for the infills are

ineffective when used in unconfined frames. It is worth mentioning that many buildings with similar characteristics showed the same damage pattern.

The observed damage in these recent post-2010 multi-storey RC buildings, despite less extensive, is very similar to the one described for the 1990s structures. The damage pattern highlights a significant need for additional design requirements to be included within the KTP-N.2-89 such as the inclusion of Damage Limit States checks and the need to avoid unconfined infills. However, it is worth mentioning that the Damage Limit States requirements of the Eurocode 8 have demonstrated to be ineffective in a number of occasions *e.g.*, [7.22][7.23], and that more strict limits should be used to ensure the design expected behaviour of the infills.

Figure 7.24: Typical post-2010 multi-storey RC building compliant with KTP-N.2-89 with integrated aspects of Eurocode 8: a) north-east facade; b) south-east side; c) indicative plan view



Figure 7.25: Typical post-2010 multi-storey RC building compliant with KTP-N.2-89 with integrated aspects of Eurocode 8: a) exterior damage related to the interaction with the stairs; b) damage on the landing of the stairs



Figure 7.26: Typical post-2010 multi-storey RC building compliant with KTP-N.2-89 with integrated aspects of Eurocode 8. Unconfined internal infill showing damage at the a) 2nd storey; b) 5th storey



Figure 7.27: Typical post-2010 multi-storey RC building compliant with KTP-N.2-89 with integrated aspects of Eurocode 8. a) exterior damage due to torsion; b) failure of unconfined infill

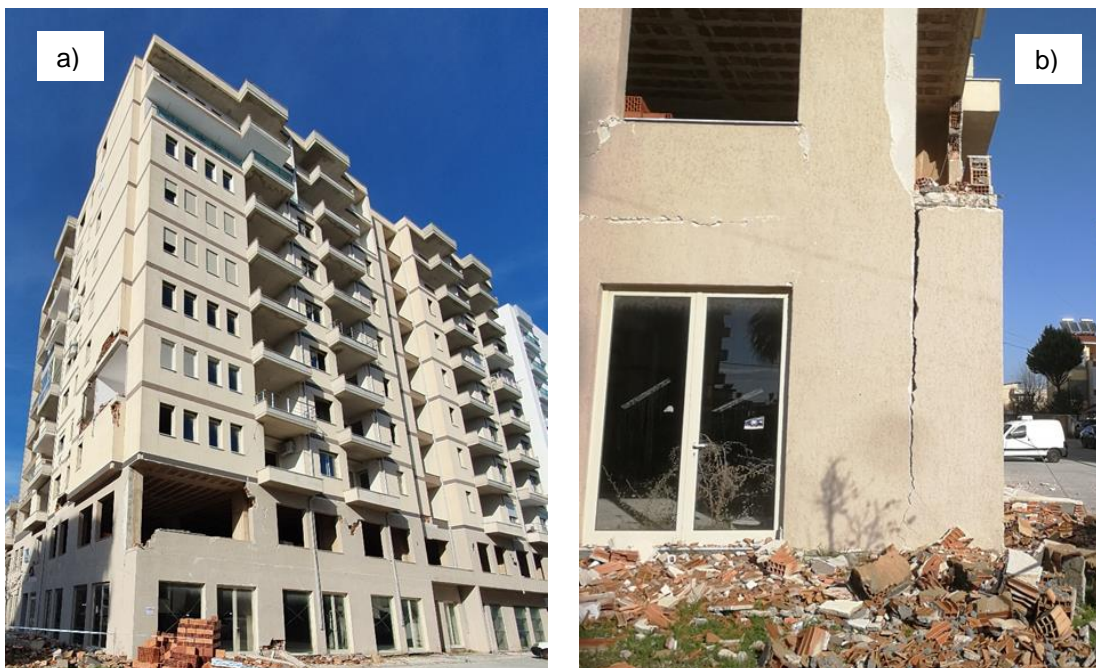

Figure 7.28: Typical post-2010 multi-storey RC building compliant with KTP-N.2-89 with integrated aspects of Eurocode 8. Effects of the belt beams in confined and unconfined infills.



7.3.3 Cases of RC buildings with structural damage

This section illustrates the few observed RC buildings with structural damage. It is worth mentioning that no reference is herein made to the collapsed buildings. Indeed, such buildings

were already demolished at the time of the mission and no considerations are reported here due to lack of direct observations.

Figure 7.29 shows the shear and axial load failure of one external (a) and one internal (b) columns of a RC multi-storey building in Durrës. Although the year of construction is unknown, it is evident that the quality of both the materials and the structural details is very poor for this case study. Figure 7.29 shows the presence of weak concrete (possibly with low percentages of cement), smooth aggregates, plain round longitudinal bars, particularly small stirrups missing the 135° hook and showing a particularly large spacing.

Based on this information, it is fair to say that likely this building was designed and/or constructed without abiding the code and with a clear lack of quality control on the construction materials.

Figure 7.29: Case with structural damage showing shear and axial failure in a) external column; b) internal column

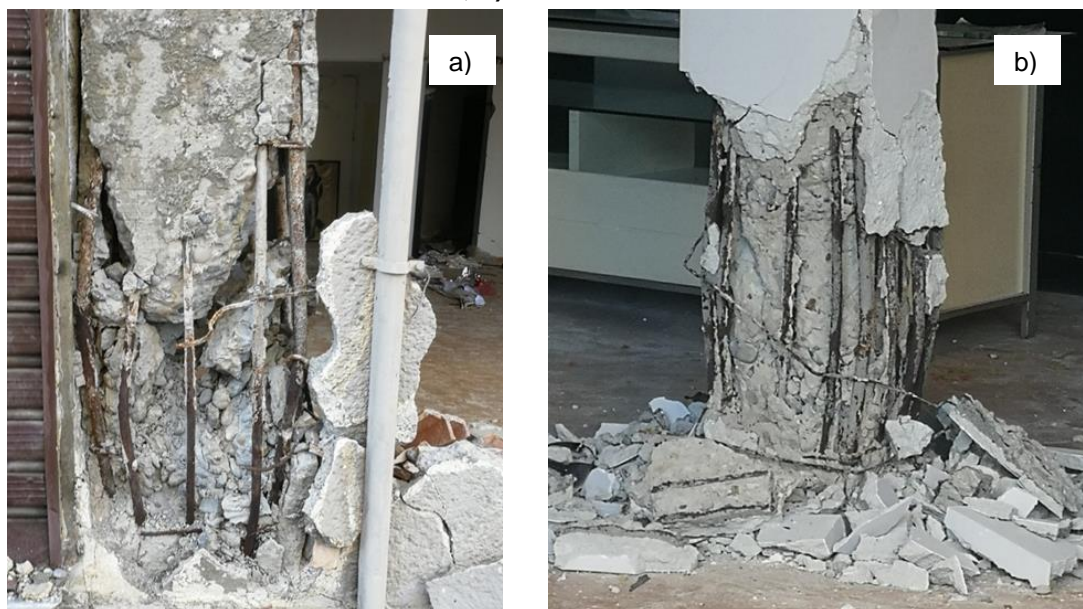

7.4 Single-family rural houses

The single-family rural houses inspected during the mission are located in the village of Bubq in Krujë municipality. Some of these houses, according to information gained from local engineers, were already damaged by the earthquake in September 2019, and then collapsed in the seismic event on the 26th November. No casualties were registered in this area, although many of these structures showed a poor seismic response mainly caused by an inadequate seismic design and unauthorised interventions carried out by local artisans with little input from engineers.

The house in Figure 7.30a has the typical configuration of the single-family rural houses inspected in this area. It is a 2-storey house, classified as URM building. The 1st floor of this house was built in 1992 by the owner using hollow concrete blocks bonded with cement mortar for the bearing walls (Figure 7.30b) and RC for the slab (Figure 7.30a). In 1997, the 2nd floor was added as well as the portico and the veranda at the 1st and 2nd level, respectively. The 2nd floor, which lacks connections with the veranda of the 2nd level as highlighted by Figure 7.30a, is a hollow core precast concrete slab supporting a timber truss for the roof tiles (Figure 7.30a, and c). The house,

which was already damaged by the earthquake in September, completely collapsed in November due to the torsion failure of the portico supported by columns, poorly reinforced as highlighted by the joint connection of Figure 7.31c and d.

Similar failures and cracks were also observed in other single-family houses of the same typology with floor plans which differ in sizes. Local engineers confirmed that the 1st and the 2nd levels of these inspected houses were also built at different time, using different materials and structural floors for the 1st and 2nd level. Figure 7.32 shows the failure of a single-family house with a plan geometry smaller than the ones in Figure 7.30. The observed damage confirms that the failure is triggered by torsion of the portico, as highlighted by the horizontal cracks on the top columns of the 1st level and overturning of the side façade.

Figure 7.30: Collapsed single-family rural houses in Bubq. URM building with hollow concrete blocks and RC slab at the 1st level and hollow brick waffle concrete slab at the 2nd level



Figure 7.31: Collapsed single family rural house in Bubq: a) severely damaged side façade b) internal view of the failed portico, c) and d) details of the poor reinforced columns of the portico at the joint connections.



Figure 7.32: Extensive damage in single-family rural house in Bubq



7.5 Historical buildings

Albania has a rich history and a large presence of built heritage around the country. The report published by the Government of Albania and its international partner locates 352 monuments/sites and 41 protected zones in the earthquake-affected areas [7.1]. Multiple historic buildings and monuments suffered from the November earthquake. The analysis of the damage that occurred to ancient masonry buildings is the necessary first step to understand the seismic behaviour of their structural components. During the field mission, the team visited the castles of

Krujë, Prezë and Durrës, for most of the part accompanied by Mr Olsi Plasa, Director of the Tirana Culture Heritage Directorate (Figure 7.33).

Figure 7.33: Location of the visited castles. Tirana shown for reference

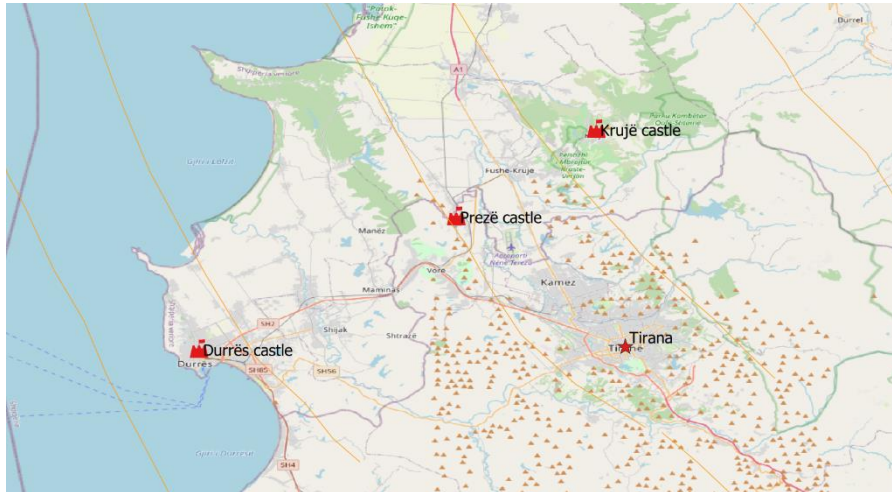

Source: OpenStreetMap

7.5.1 Durrës Castle

The Castle of Durrës was built in the 1st century BCE and acquired its final form in the 5th century with the Byzantine emperor Anastasius I Dicorus. The fortification walls were devastated in an earthquake in 1273 and had to be extensively repaired [7.9].

Under the Republic of Venice, the castle was reinforced with several guard towers and the walls were reinforced during the Ottoman Empire. The walls present different typologies of stone and brick masonry. Signs of the alteration and repair of the walls and towers are visible, as shown in Figure 7.34, such as local reconstruction of the masonry and repair of the corners with visible metallic elements on the exterior side.

Figure 7.34: Visible repairs of the walls and towers of Durrës (a) Venetian tower and (b) gate tower



The damage caused by the November earthquake is concentrated in the tower gate located at the intersection between Anastas Durrsaku street and Xhamia street. A view of the tower before and after the earthquake is provided in Figure 7.35. The tower has a squared shape, offset towards the road with respect to the fortification walls. Based on observation shown in Figure 7.35a it is possible to identify different masonry types, possibly associated to several alterations over time. The north façade (N) shows a stone masonry base course supporting brick masonry walls. Towards the top, the wall changes from brick to stone masonry. On the contrary, the west façade (W) appears to be made of quite uniform stone masonry until the merlon, which shows a different type of stone masonry. Local repair of stones with bricks is also visible on the wall. The stone masonry at the merlons appears to be in poor condition, with visible decay and loss of mortar. The different types of masonry connect at the corner where the two walls rely on a poor interlocking, if any. Although it was not possible to access to the interior of the tower, from the hole left by the collapsed masonry it was possible to observe an extensive presence of vegetation growing on the interior side of the walls. The presence of vegetation is sign of both lack of roofing and lack of maintenance, which could be triggers for developing weak points leading to the observed damage.

The type of failure experienced by the tower consisted in the collapse of the corner, which resulted in the obstruction of the pavement and part of the road due to the out-of-plane collapse of the masonry walls. From Figure 7.36 it is possible to observe a significant presence of roots on the failure plane of the north wall, whereas the failure plane on the west wall is extremely vertical and regular suggesting the absence of interlock between the different masonries. Also, it appears that the external layer of the masonry was added at a later stage, with absence of transversal connectors to the existing masonry. This way of thickening the existing masonry walls of defensive architecture was practiced during the Ottoman period [7.10].

The collapsed material is quite varied (Figure 7.35b), and the masonry appears to have failed in blocks, with only a small amount of material resulting disintegrated. This type of failure is not very common in masonry and can be explained by the presence of very thick mortar joints, generally thicker and stronger than the units, as can be observed in Figure 29. It is unknown whether the brick masonry is part of the original wall or it is a more recent alteration. However, this type of construction with thick mortar joints is quite common in the Byzantine brick masonries, in construction located in seismic areas and/or on subsidizing soils [7.11]. In the studies conducted by Baronio *et al.* [7.12] on similar masonry, this material was observed to behave more as a conglomerate or concrete rather than mortar, since the size of its aggregates reaches values closer to a modern concrete rather than a traditional mortar for joints [7.12].

Figure 7.35: View of the gate tower before (a) and after (b) the November earthquake

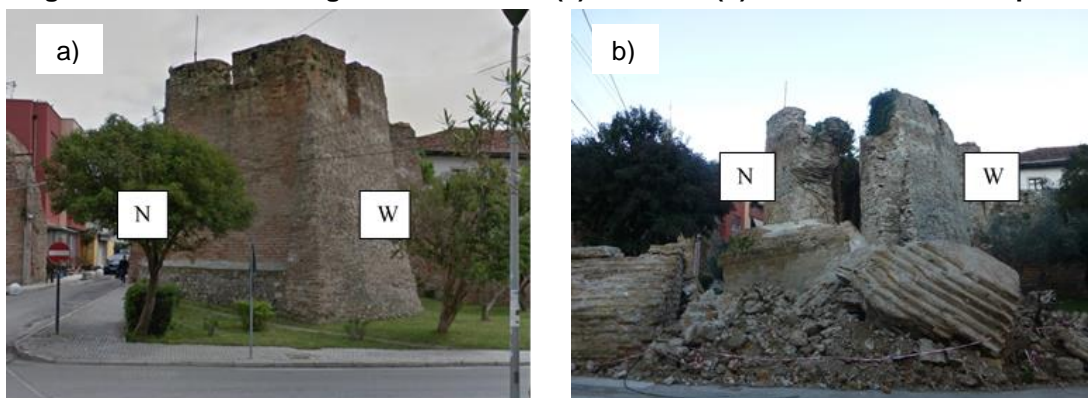

Source: image a) – Google street view

Figure 7.36: View of the surfaces of rupture of the gate tower



Figure 7.37: Close view of the collapsed masonry in Durres



7.5.2 Krujë Castle

The second castle visited was the Castle of Krujë, located on a hilltop overlooking Krujë town (Figure 7.38) and is considered the symbol of Skanderbeg's rebellion against the Ottoman Empire. It is considered as one of the most significant expressions of medieval constructions in Albania. Within the castle area there are several monuments, some of which were found with significant level of damage after the November earthquake. The castle is surrounded by fortification walls and sits on a rocky substructure formed by different blocks of rocks fallen off the mountain that constitute the base of the castle. The Preliminary Technical Assessment of the Architectural and Archaeological Heritage in South East Europe, published by the European Commission and adopted by the Ministry of Tourism, Culture, Youth and Sports in 2006 reports that the rocky substructure located under the clock tower and under the south-western wall close to the Tekke of Dollma, a religious building, is in dangerous condition because it displays fissures and cavities [7.13]. Both structures were visited during the mission as they were reported to have suffered damage due to the November earthquake.

The concerns related to the geological stability of the rocky hill led to a series of interventions of consolidation of some critical areas. Some anchors are visible in Figure 7.39 on the hill's side near the clock tower. The November earthquake caused the formation of some new cracking in the ground around the tower, which was pointed out during the survey by the local contacts.

Figure 7.38: View of the Krujë Castle from the air



Source: Alamy stock photo, www.alamy.com

Figure 7.39: View of the anchors present on the hill's side near the clock tower



Source: <https://goaslocal.com/tour-category/culture-heritage-tours>

The clock tower also suffered extensive damage due to the November earthquake. The tower is an unreinforced stone masonry structure dating from the 12th century, with a quasi-pyramidal

shape at the bottom and a squared geometry at the top. Access to the tower is understood to be on the front and rear sides from two doors located at different levels. A timber staircase is connecting the entrance to the top floor. The structure underwent a series of interventions: the first intervention took place in the 1920-1930s and consisted on the reconstruction of the masonry of the tower in its middle part; a second intervention took place in the 1970 to reconstruct the top of the tower and included the introduction of what was observed to be a RC rigid floor, possibly with concrete ring beams, and columns with tuff cladding supporting the timber roof.

Views of the tower before and after the earthquake is provided in Figure 7.40. The type of failure observed is a global mechanism consisting of long vertical cracks on the walls and a significant displacement out of plane of part of the masonry walls towards the corners. No damage is observed on the belfry, at the top of the tower, which proofs the high rigidity of the new system introduced with the 1970s intervention. Such high rigidity is usually not compatible with that of historic masonry, being often the source of additional damages in earthquakes.

The performance of historic masonry towers during earthquakes rely on a series of parameters such as soil-structure interaction, slenderness, quality of materials, presence of openings, walls interlocking and typology of floors [7.14]. All the intrinsic critical vulnerabilities of this structural typology can be even worsened, when inadequate restoration works are carried out, which often lack in understanding the quality of the existing materials [7.15]. Many studies have been undertaken to study the structural behaviour of towers under horizontal loading to be able to evaluate the performance of different retrofitting techniques. As far as the efficiency of the retrofitting interventions of old stone masonry is concerned, tying of the walls using steel rods has been proven to increase the out of plane capacity of the tower, whereas the replacement of the old timber floors/roof with RC slabs, widely used as restoration techniques, particularly at height, affect the mass and the stiffness of the structure and lead to dynamic behaviour changes [7.16].

Figure 7.40: View of the Krujë clock tower before and after the earthquake



Source: a) WikiCommons https://commons.wikimedia.org/wiki/File:Krujë_Watchtower_and_Castle_Walls.jpg

On the other side of the castle, another building was found in extremely poor condition at the time of the survey. The building in question is the Tekke of Dollma, which is a religious construction dated back to 1789 and proclaimed Monument of Culture in 1973 [7.13].

The building square shape turns into hexagonal in the upper part to envelope the central dome (Figure 7.41). The dome is sitting on squinches which are in turn resting on the stone masonry walls. The structure shows in-plane cracking of the masonry walls, with cracks developing diagonally from the bottom part of the corners through the openings (Figure 7.42b). The failure of the corners is likely to be the cause of the cracking observed on the dome, visible from Figure 7.43. From a glimpse of the inside, the dome presents a meridian crack pattern, with no cracking shown at the crown and regular cracking like “slices” in the lower part, as shown in the schematic illustration proposed by Jacques Heyman [7.17], shown in Figure 7.44. This type of failure is generally caused by movement in the dome’s support causing an increase of the dome’s span.

When comparing the “before” and “after” figures of the exterior of the Tekke of Dollma (Figure 7.42), it is possible to observe that cracking was present on the masonry walls at the same locations before the November earthquake. The original causes of the cracking could be connected to the ground instability observed in the area, as well as previous earthquakes [7.13]. Therefore, the November earthquake appears to have caused a progression of the existing damage, significantly increasing the size of the pre-existing crack pattern.

Figure 7.41: Tekke of Dollma before the earthquake



a) front view



b) rear view

Source: a) https://en.wikipedia.org/wiki/Dollma_Tekke and b) <https://mapio.net/pic/p-63037109/>

Figure 7.42: View of the Tekke of Dollma a) before and b) after the November earthquake



a) before



b) after

Source: a) <http://www.visionsoftravel.org/Krujë-dollma-teqe-albania/>

Figure 7.43: View of the cracking of Tekke of Dollma dome



Figure 7.44: Exaggerated schematic illustration of cracking of a dome due to increase of span [7.17]

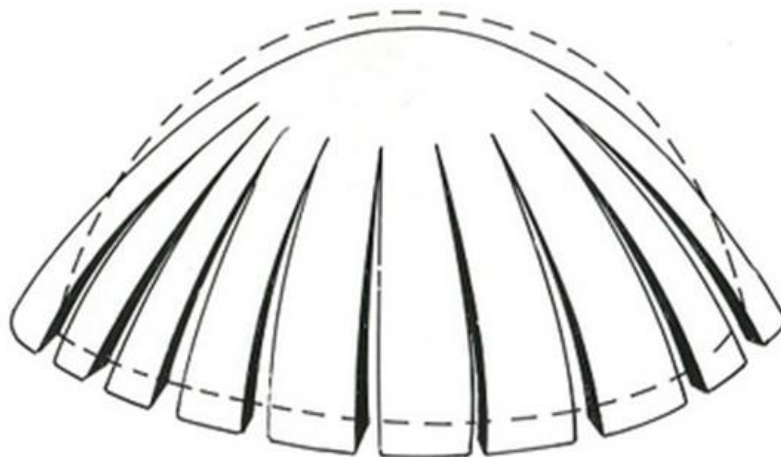

7.5.3 Prezë Castle

The last castle visited during the field mission is the Prezë Castle. Built in the 15th century, the castle was designed to follow the conformation of the hilltop, resulting in an irregular pentagonal shape, with towers in each corner connected with fortification walls (Figure 7.45). All towers are circular except for one that was reshaped into a 14.5 m high clock Tower in 1852. The clock tower has a rectangular shape of 4.2x4.2 m and has two storeys accessible through an internal staircase. The tower has lost its original Ottoman style, which is visible from the photos available at the National Archive provided by Mustafaraj and Yardim [7.18] (Figure 7.46). The photos capture the damage suffered by the towers in different periods, most likely due to earthquakes. Therefore, the current configuration of the tower is the result of a series of alterations over time occurred to change its use and to repair previous earthquake damage. Information on the condition of the tower before the earthquake is provided by Mustafaraj and Yardim [7.18], who conducted a structural assessment of the tower in 2014. The results of the assessment identified the need of an intervention of retrofitting as the masonry of the tower was found with surface degradation and structural cracking propagating throughout the entire height of the tower, with the most significant cracking observed on the east side.

In summer 2019, works have been undertaken on the tower which included the strengthening of the masonry walls for overturning with the introduction of metallic ties and the addition of an internal metallic structure to support a spiral staircase to access the 2nd floor. Some pictures of the intervention are available from the social media webpage of the company that performed the works (Figure 7.47).

Figure 7.45: View of Prezë Castle from a drawing on the wall of the restaurant of the castle

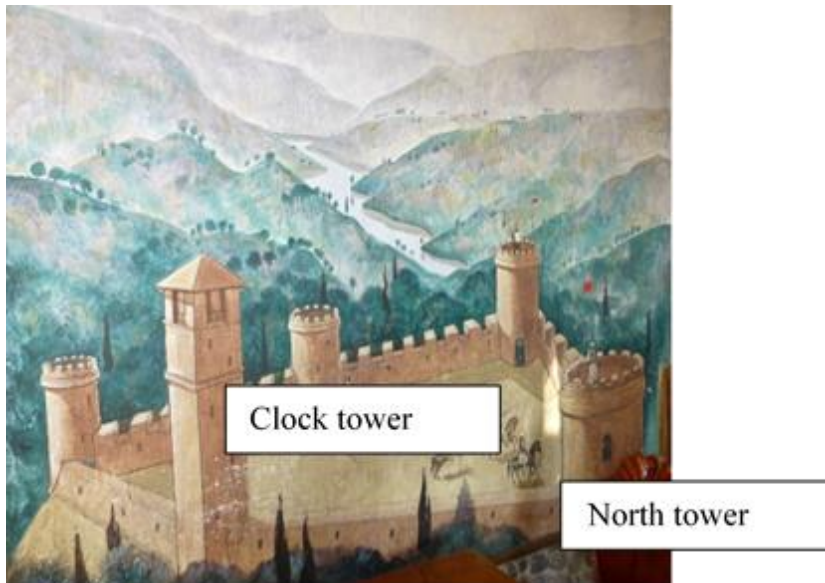

Figure 7.46: Damage suffered by the Prezë castle clock tower at different times [7.18]



Figure 7.47: Photos showing the intervention on Prezë clock tower in summer 2019



Source: www.facebook.com/LeonKonstrukcion/photos/a.380581722076822/1671278643007117/?type=3&theater

A view of the tower before and after the earthquake is provided in Figure 7.48. From Figure 7.48b it is possible to observe that the clock tower completely lost the roof and the columns framing the top floor. Figure 7.49 shows the opposite east side of the tower, where the damage is more extended and includes the loss of the masonry of the upper third of the tower, below the top floor.

Where the masonry was reinforced with anchors, the walls resisted the out of plane forces by activating the parallel wall and/or perhaps the internal steel structure and engaging the shear capacity of the transverse walls. In this part, the masonry shows vertical cracking between ties, some of which could have been present since before the November earthquake.

Figure 7.48: View of the Prezë clock tower: a) before and b) after the 2019 earthquake



a) before



b) after

Figure 7.49: Damage observed on the south side of the Prezë clock tower: a) overview and b) closeup



a) overview



b) closeup

The damage caused by the November earthquake also occurred to the North tower (Figure 7.45). The tower has a circular shape and is made of stone masonry walls. Visible alteration to the original configuration of the tower observed during the visit are the introduction of a RC floor to create a terrace on the roof of the tower (Figure 7.50a) and the construction of a building on the side of the fortification walls and adjacent to one of the sides of the tower (Figure 7.50b). The damage occurred on the outer side of the tower, facing the cliff. This side is the most vulnerable due to the lack of confinement provided by adjacent structures. In this part, the masonry collapsed out of plane, whereas the stiff slab remained undamaged (Figure 7.51). The presence of the new heavy RC floor activated a larger seismic mass and therefore resulted in a higher demand for overturning capacity on the wall.

Figure 7.50: View of the Prezë north tower and alteration to the original configuration: a) new reinforced concrete slab, b) new construction adjacent to the side of the tower



a) new RC slab



b) new construction adjacent to the tower

Figure 7.51: View of the damage to the Prezë clock tower



Finally, the fortified walls of the castles suffered some damage due to the November earthquake. The same type of damage was observed in both the castles of Krujë and Prezë. The damage was localised and consisted in the out-of-plane failure of the masonry merlons, sometimes affecting groups of them as shown in Figure 7.52a. The vulnerability of the merlons to earthquake, especially due to out-of-plane mechanisms, is a common type of vulnerability characterising ancient fortified architectures. This type of mechanism was observed occurring in previous earthquakes even at low values of peak ground accelerations starting from about 0.05g [7.19].

Figure 7.52: Collapsed sections of the fortified walls: (a) Krujë castle, (b) Prezë castle

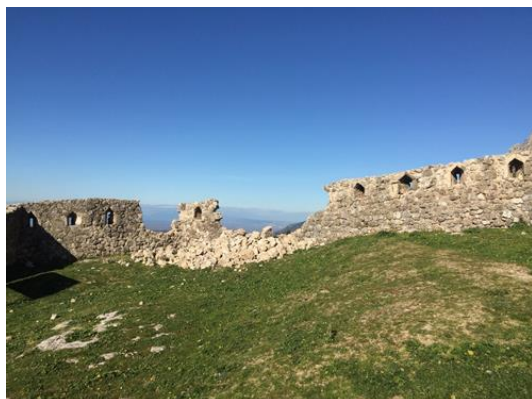

a) Krujë castle



b) Prezë castle

7.6 References for chapter 7

- [7.1] CEN. EN 1998-1: 2005. Eurocode 8: Design of structures for earthquake resistance – Part 1: General rules, seismic actions and rules for buildings, European Committee for Standardization, Brussels, 2005.
- [7.2] KTP-N.2-89: 1989. Kusht Teknik Projektimit për Ndërtimet Antizismike, The Scientific Council of Ministry of Construction, Albania
- [7.3] KTP-9-78: 1978, Albanian Masonry Design Code, The Scientific Council of Ministry of Construction, Albania
- [7.4] Bilgin, H., & Huta, E. (2018). Earthquake performance assessment of low and mid-rise buildings: Emphasis on URM buildings in Albania. *Earthquakes and Structures*, 14(6), 599-614
- [7.5] Bilgin, H., & Korini, O. (2012). Seismic capacity evaluation of unreinforced masonry residential buildings in Albania. *Natural Hazards and Earth System Sciences*, 12(12), 3753
- [7.6] Bilgin, H. (2015). Typological Classification of Churches Constructed During Post-Byzantine Period in Albania. *Gazi University Journal of Science Part B: Art Humanities Design and Planning*, 3(1), 1-15
- [7.7] Abazaj, A., (2019) Prefabrication and Modular Construction Dwellings in Albania, *International Journal of Scientific & Engineering Research*, Volume 10, Issue 8, August-2019, ISSN 2229-5518
- [7.8] Albania, Post-Disaster Needs Assessment, Volume A report, Tirana, February 2020, Albania Council of Ministers, European Union, UN Albania and World Bank Group, https://ec.europa.eu/neighbourhood-enlargement/sites/near/files/albania_post-disaster_recovery_a_v9.0.pdf
- [7.9] https://en.wikipedia.org/wiki/Durr%C3%ABs_Castle

- [7.10] Nicolle, D., Ottoman Fortifications, 1300-1710. 2010. Series editor Marcus Cowper.
- [7.11] Binda, L., Tedeschi, C., Baronio, G., Influence of thick mortar joints on the early and late mechanical behaviour of Byzantine constructions, Transactions on the Built Environment, vol 39, 1999
- [7.12] Baronio, G., Binda, L. & Tedeschi C., Thick Mortar Joints in Byzantine Buildings: Study of their Composition and Mechanical Behaviour, Int. Conf. on Studies in Ancient Structures, ed. G. Ozsen, Istanbul, Turkey, pp.235-244, 1997
- [7.13] Integrated Rehabilitation Project Plan. Survey of the Architectural and Archaeological Heritage (IRPP/SAAH) in the framework of the European Commission/Council of Europe Joint Programme. Regional Programme for Cultural and Natural Heritage in South East Europe 2003-2006. Preliminary Technical Assessment (PTA). The castle of Krujë, Krujë, Albania. Adopted by the Ministry of Tourism, Culture, Youth and Sports of the Republic of Albania on September 2006.
- [7.14] Formisano, A., Milani, G, Seismic Vulnerability Analysis and Retrofitting of the SS. Rosario Church Bell Tower in Finale Emilia (Modena, Italy), 2019, Front. Built Environ. 5:70. doi: 10.3389/fbuil.2019.00070
- [7.15] Colapietro, D., Fiore, A., De Fino, M., Netti, A., Fatiguso, F. and Marano, C.G., Assessment of the Seismic Vulnerability of a Masonry Bell Tower by non-destructive Experimental Techniques, Seismic Assessment, Behavior and Retrofit of Heritage Buildings and Monuments, edited by Ioannis N. Psycharis, Stavroula J. Pantazopoulou, Manolis Papadrakakis, Computational Methods in Applied Sciences, 2015.
- [7.16] Stavroulaki, M.E., Dynamic Behavior of Aggregated Buildings with Different Floor Systems and Their Finite Element Modeling, 2019, Front. Built Environ. 5:138. doi: 10.3389/fbuil.2019.00138
- [7.17] Jacques Heyman, The Stone Skeleton, Structural Engineering of Masonry Architecture, Cambridge University Press, 1995.
- [7.18] Mustafaraj, E., Yardim, Y., Structural Assessment of Preza Clock Tower, Albania, ICESA 2014.
- [7.19] The Muisne, Ecuador Earthquake of 16 April 2016. A field report by EEFIT. September, 2018.
- [7.20] fib Bulletin 43 (2008), Structural connections for precast concrete buildings, Guide to good practice prepared by Task Group 6.2, International Federation for Structural Concrete (fib), Lausanne, Switzerland
- [7.21] UNDP/UNIDO (1985), Building construction under seismic conditions in the Balkan region, Volume2: Design and construction of prefabricated reinforced concrete building systems, UNDP/UNIDO Project RER/79/015, United Nations Industrial Development Organization executing agency for the United Nations Development Programme, Vienna, 1985
- [7.22] De Luca F, Woods GED, Galasso C, D'Ayala D (2018). RC infilled building performance against the evidence of the 2016 EEFIT Central Italy post-earthquake reconnaissance mission: empirical fragilities and comparison with the FAST method. Bull Earthq Eng. doi: 10.1007/s10518-017-0289-1
- [7.23] Perrone, D., Calvi, P.M., Nascimbene, R. et al. Seismic performance of non-structural elements during the 2016 Central Italy earthquake. Bull Earthquake Eng 17, 5655–5677 (2019). <https://doi.org/10.1007/s10518-018-0361-5>

8 Final remarks and lessons learned

On November 26th a strong earthquake with a moment magnitude of M_w 6.4 struck near Durrës and Thumanë in Albania. The epicentre was 22 km from Durrës and 30 km from Tirana and the depth was estimated at 38 km. This was the strongest earthquake to hit Albania in more than 40 years, and the deadliest earthquake globally for the entire 2019. At least 10 aftershocks with $M_w > 4$ were registered, some with M_w as high as 5.4. The earthquake had impact on over 200,000 people, from which approximately 50,000 affected directly. The earthquake caused 51 fatalities and over 900 injuries, including over 250 people injured during the aftershocks. The fatalities occurred primarily due to the collapse of 10 buildings in the city of Durrës and in the town of Thumanë (in Krujë municipality). Approximately 17,000 people were displaced due to the loss of their homes. First responders managed to rescue 48 people from collapsed houses.

The earthquake caused damage to various type of assets in the most affected 11 municipalities. Damages were reported to 321 (24%) educational institutions in the 11 affected municipalities with overall value of damage estimated of approximately 64 million euro. It was reported that 36 health care facilities (8% of total in 11 Municipalities) were partially or fully damaged. The total effects were estimated at circa 10 million euro. A total of 11,490 housing units were categorised as fully destroyed or demolished and need to be rebuilt. In addition, over 80,000 of housing units were either partially or lightly damaged, needing repair and refitting. Overall, 18% of total housing units have been affected. The total effects are valued at almost 700 million euro. Damages were reported for 57 buildings from the Ministry of Defence and one firefighting station had to be demolished. The assessment reveals that the total effect of the disaster in the 11 municipalities amounts approximately 985 million euro. Most of the damages are recorded in the Housing sector (78.5%), followed by the Productive sector (8.4%) and the Education (7.5%) sector. In relation to the geographic distribution of damage and loss, the municipality of Durrës was overwhelmingly the most affected with over 300 million euro or 32% of the total damage and loss, followed closely by Tirana with approximately 285 million euro or 30%, and thirdly Krujë with approximately 84 million euro or 9%. In total the earthquake has caused effects that are equivalent to 6.4% of 2018 GDP in damages and to 1.1% of GDP in losses.

Between 13th and 18th December an EEFIT team of six engineers visited the most affected areas from the M_w 6.4 November earthquake focusing on the housing sector. The key findings regarding the observed seismic performance of different building typologies is summarised below:

Pre-1990 URM buildings in solid silicate and clay bricks showed a good seismic performance. This is likely to be attributed to the good connections observed among load bearing walls and the presence of RC slabs working as a diaphragm under seismic loads. The only two buildings of this type which collapsed during the seismic event in November 2019 were made of walls in solid silicate bricks and hollow core precast concrete slabs. Such failures, characterised by overturning of walls, followed by collapse of entire slab strips are likely to be associated to earthquake-induced settlements. In many buildings of this type, unauthorised interventions (e.g., additional floors, closure and creation of new openings, use of different masonry for reparation) were observed which together with the overall lack of maintenance may become the cause of possible damage and collapse in a future earthquake, especially if of higher intensity. Furthermore, since these buildings were built before the new seismic design codes, it is strongly recommended the use of non-linear seismic analyses to assess their structural performance and to take into account their geometric irregularity observed on site. This will allow to make informed decisions through retrofitting/rehabilitation strategies for increasing their seismic resilience, if required.

Pre-1990 prefabricated large-panel buildings

These buildings performed very well. The only damage observed was in the form of hairline horizontal cracks in the interface between floor and wall panels and vertical crack in the interface between vertical panels concentrated in the first two floors. These observations are based on the field visits neighbourhoods with clusters of prefabricated panel buildings in Durrës and in Laç where in both cases these buildings were in proximity of damaged buildings from other types. This is in line with the observations from other strong earthquakes in the past that affected countries where prefabricated panel buildings are widely used.

Multi-storey RC buildings

Damage in RC buildings was observed mainly in mid- to high-rise (above 8 storeys) RC frame buildings which were designed to the latest seismic code of 1989. Many typical 1990s multi-storey RC buildings located in Durrës between the Port and the Niko Dovana Stadium have similar characteristics and show a similar damage pattern. The buildings of this kind which were inspected by this team are typically regular in both plan and elevation. No RC core wall is generally present, likely due to the lack of stiffness requirements in the design code (e.g., damage limit states limit displacement). Horizontal forces are resisted by the frame action only. Usually, shops are located at the ground level of these buildings, while the upper stories are for residential use.

For all the visited buildings of this typology, the infilled panels are made by large hollow bricks (25×25×20 cm). The interaction of the flexible structure with such stiff infills led to significant non-structural damage characterised by diffuse shear cracks in the infills themselves. Moreover, some of the unconfined infills (i.e., not enclosed by RC members) have collapsed, or showed heavy damage. In addition, the typical damage pattern was also characterised by horizontal cracks in the lower side of the floor slabs. This is related to a poor connection between the top side of the infill panels and the adjacent floor slabs. This damage pattern is typically distributed over the lower storeys (five, on average).

An interesting observation from Durrës is that many modern, post-2010, multi-storey RC buildings had also significant non-structural damage. This was observed both in the city centre and in the “Beach” area, where many hotels are concentrated. These structures usually differ from the typical 1990s RC multi-storey buildings because most practitioners would use detailed formulations in Eurocode to better implement the recommendations in the Albanian code. In many of these buildings, damage was mostly concentrated in the staircase and in the interior infill panels. This is likely related to the torsion-related displacements generated by the eccentric core wall. The staircase was generally not able to accommodate such displacements and experienced large shear cracks in the landings. Extensive damage was observed in the lower storeys (typically five) of these buildings. Similarly to the typical 1990s multi-storey RC buildings, the infilled panels are generally composed of large hollow bricks (25×25×20 cm). These bricks were often observed both for the external and the internal walls. Consistently with the 1990s RC buildings, the interaction of the flexible structure with the stiff infills led to significant non-structural damage. This type of damage was higher in the internal partitions due to a lack of confinement and to the lack of interconnection between perpendicular infills.

Single-family rural houses

Buildings of this types were observed by the team in the village of Bubq in Krujë municipality. No casualties were registered in this area, although most of these structures show a poor seismic response mainly caused by an inadequate seismic design and unauthorised interventions carried out by local artisans with little input from engineers. Such buildings, built in stages starting in the late '90, have mixed structural system made of load bearing walls with different masonry types for each storey (e.g. concrete, clay bricks), porticoes made of RC columns and beams, and

dissimilar floor types for each storey (e.g. concrete slab, hollow core precast concrete slabs). The observed damage for these buildings confirms that the failure is usually triggered by the observed structural irregularities in plan and elevation causing torsion and overturning of walls.

Historical buildings

Albania has a rich history and a large presence of built heritage around the country. These buildings are particularly vulnerable to disasters such earthquakes, and this poses a risk to their legacy. Cultural heritage is not only the carrier of historical, social cultural values but it has also an important economic value for some parts of the country. The preservation of cultural heritage in locations like Krujë and Prezë, is essential for the economic development of the towns.

Part of the cultural heritage present in the most affected areas suffered extensive damage due to the 26th November earthquake. Based on the observation of the defensive architecture visited during the mission, the damage mainly occurred in the towers and merlons. The failure mechanisms observed often consisted of out-of-plane movements of masonry walls; however, the causes of the damage are quite different and often a combination of multiple factors. The status of conservation of the structures together with pre-existing damage was found to be one of the main causes leading to the observed failure mechanisms, together with soil settlements. Moreover, our observations highlighted that historical alterations and past structural interventions can substantially modify the dynamic behaviour of the historic structures and can result in an increase of their vulnerability.

The earthquakes from 21st September and 26th November that stroke near Durrës marked some intrinsic vulnerabilities in the Albanian building stock which were not fully demonstrated after these earthquakes but could materialise in the form of significant damages, losses and casualties in a future strong earthquake. The M_w 6.4 earthquake on 26th November stroke in a very favourable location along the fault with an epicentre in a rarely populated area and at maximum distance from Tirana and Durrës. The epicentre of the M_w 5.6 earthquake on 21st September was estimated to be on the outskirts of Durrës and hence close to Tirana too, but the earthquake was not strong enough to cause significant damage. If the epicentre of the 26th November earthquake was near the epicentre of the 21st September earthquake this report would probably look very differently. However, the ten casualty-causing buildings and the widespread non-structural damage in the modern multi-storey residential RC buildings highlighted some significant deficiencies in the Albanian design and construction practice which could be manifested through significant damages, losses and casualties related to the following residential building typologies widely present in Albania:

- **Pre-1990 URM multi-family residential buildings with calcium-silicate bricks and slabs of pre-cast panels:** Two such five-storey buildings in Kodër-Thumanë collapsed and this caused almost half of all fatalities (24 out of 51 in total). The low material quality and the lack of proper connection between the floor RC panels and the masonry walls are believed to be the main cause of the collapse. These buildings were built according to standardised design templates approved by the Albanian governmental authorities proposing cost-effective layout for URM constructions from two to five stories and such buildings can be seen all over Albania. The team visited also four buildings of similar type in Laç that were classified from the authorities to be damaged beyond repair. A proper seismic risk mitigation program in Albania need to address this structural typology and their standardised design could facilitate their allocation, assessment and the development of standardised seismic retrofit solutions leading to potential economic savings.
- **Mixed-use RC MRF buildings built during the 1990s:** one third of the collapsed buildings fit into this category, but the team observed in Durrës other buildings of this type

and construction period with significant structural damage in the columns of the ground floor. These are typically four to six storeys high mixed-use buildings with shops on the ground floor and apartments above. Their vulnerability is either due to poor reinforcement detailing, poor material and construction quality due to the challenging economic conditions and the ineffective law enforcement in the first years after the fall of the communist regime. Albania will benefit from a country-wide programme for seismic assessment of existing buildings which needs to prioritise the seismic assessment of 1990s mixed use and multi-family residential buildings which are potentially bearing significant seismic risk.

- **Modern multi-storeys RC MRF multi-family residential buildings:** many such buildings in Durrës sustained severe non-structural damage manifested mainly through severe cracking or out-of-plane failure of infills in the first 4-5 storeys, cracks in the stair legs and distorted elevator doors. The main reason for this is judged to be the combination of flexible structural system and rigid infills which is due to deficiencies in the current Albanian seismic code that does not provide drift limitations for Damage Limit States. In addition, comparison of the elastic design response spectra based in Eurocode 8 and the current Albanian seismic code showed that the response spectrum definition in the current Albanian seismic code may underestimate the spectral accelerations (almost twice in the 1-2s period range). This observation is supported also from the comparison of the elastic design spectra with the response spectra of the recorded strong motions in Tirana and Durrës, where for the case of Tirana the spectral accelerations are up to 2 times bigger from the code provisions for almost identical PGA and for the case of Durrës the spectral accelerations in the longer period range of 1-1.5s were identical with the code provisions but for almost twice lower PGA. The map of capable faults of Albania clearly show that a much stronger earthquake and much closer to Durrës is a realistic scenario and such an event may lead not only to serious monetary losses, but also to significant human casualties (considering that there are 30-50 apartments in each of these buildings). The third biggest city Vlorë has also many modern multi-rise and is in high seismic hazard zone. The 26th November demonstrated that there is a need for a critical review of the current seismic code or for accelerated adoption of the Eurocode which will help to reduce the seismic risk associated with the future construction. It also demonstrated the need for a country-wide assessment of the expected seismic performance of these buildings in a design level earthquake and potentially seismic strengthening program focusing on stiffening the structural system or improving the infill detailing or both.

In addition, the 26th November earthquake highlighted the deadly connection between the ineffective law enforcement in the construction process and the high seismic vulnerability. For six of the ten collapsed buildings (15 out of 51 fatalities) there were media publications that the buildings were either built without the needed approvals from the authorities or had unauthorised structural interventions as adding floors or removing columns on the ground floor. It should be noted here that three of these six buildings were five to eight storeys high hotels which had only 1-2 guards inside during the earthquake and these collapses could lead to death toll of hundreds of people if during the peak tourist season.