

The Institution *of Structural* *Engineers*

Possible solution to past CM examination question

Question 2 - April 2014

Garage for snow ploughs

by Dr Peter Gardner

The information provided should be seen as an interpretation of the brief and a possible solution to a past question offered by an experienced engineer with knowledge of the examiners' expectations (i.e. it's an individual's interpretation of the brief leading to one of a number of possible solutions rather than the definitive "correct" or "model" answer).

Question 2. Garage for snow ploughs

Client's requirements

1. A new garage to store four snow ploughs.
2. Each snow plough requires a parking space 10.0m wide by 10.0m long. Clear headroom of 5.0m is required throughout. No structural elements may intrude into this space.
3. The site is 30.0m wide and 50.0m long. See Figure Q2. An access road serves the site on one side. The site and access road are surrounded on all sides by steep slopes.
4. The site slopes upwards away from the access road at a slope of 1 in 10. See Figure Q2. The floor of the garage is required to be level.
5. Sufficient doors must be provided to the garage so that three snow ploughs can exit to the access road at all times, even if the fourth plough is under repair. The door opening must have a clearance of at least 10.0m wide and 5.0m high.
6. Access to the site is via a single-track road which is usable, because of weather conditions, for only four months of the year. The longest length of a structural element that can be delivered to the site in one piece is 7.0m.

Imposed loading

- | | |
|---------------------|--|
| 7. Snow loading | Density of snow: 2.0kN/m^3 . The maximum snow depth based on a 50-year return period is 7.0m. The horizontal load imposed by snow may be taken as 30% of the vertical load. |
| Snow plough loading | 2.0kN/m^2 |

Site conditions

8. The site is located in a mountainous location at an altitude of 2000m. Basic wind speed at sea level is 46.0m/s based on a 3-second gust; the equivalent mean hourly wind speed is 23.0m/s.
 9. **Borehole 1 (top of hole at 2005m altitude)**

Ground level – 0.2m	Topsoil
Below 0.2m	Rock, allowable safe bearing pressure 400kN/m^2
 - Borehole 2 (top of hole at 2000m altitude)**

Ground level – 4.0m	Gravel, $N=20$
Below 4.0m	Rock, allowable safe bearing pressure 800kN/m^2
- Groundwater was not encountered in either borehole.

Omit from consideration

10. Detailed design of door mechanism.

SECTION 1

(50 marks)

- a. Prepare a design appraisal with appropriate sketches indicating two distinct and viable solutions for the proposed structure. Indicate clearly the functional framing, load transfer and stability aspects of each scheme. Identify the solution you recommend, giving reasons for your choice. (40 marks)
- b. After the design has been completed there is a severe winter which restricts use of the access road to only two months during the summer. Expert meteorological opinion suggests this may happen more frequently in the future. Write a letter to your client explaining the implications of this information on the construction of your proposed structure. (10 marks)

SECTION 2

(50 marks)

For the solution recommended in Section 1(a):

- c. Prepare sufficient design calculations to establish the form and size of all the principal structural elements including the foundations. (20 marks)
- d. Prepare general arrangement plans, sections and elevations to show the dimensions, layout and disposition of the structural elements and critical details for estimating purposes. (20 marks)
- e. Prepare a detailed method statement for the safe construction of the building and an outline construction programme. (10 marks)

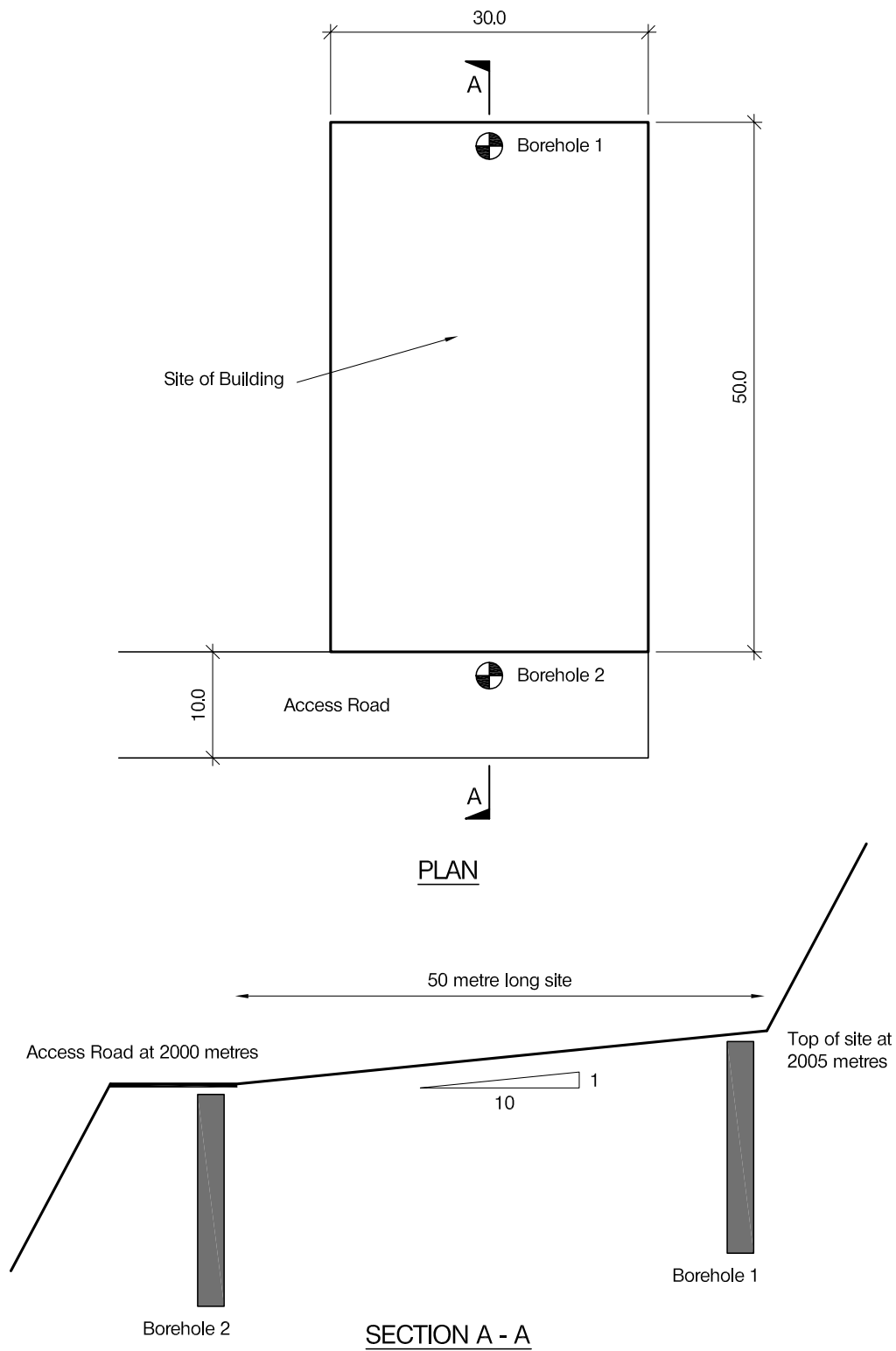

NOTE: All dimensions are in metres

FIGURE Q2

Garage for snow ploughs

This question relates to the requirement for a single-storey building to store four snowploughs. The building itself should be relatively straightforward as it boils down to a single-storey rectangular shed of relatively modest dimensions. However there are a few issues in the question that need to be appreciated and incorporated into the design but there is nothing that makes this question impossibly complicated or problematic.

The key parts of the brief are:

- A garage to store four snowploughs, each requiring a space of 10m x 10m. No structural elements may intrude into this space*.
- The building requires a clear headroom of 5m throughout.
- The site is 30m x 50m and has an access road on one side. The site and access road are surrounded on all sides by steep slopes.
- The site slopes at a pitch of 1 in 10. The floor of the garage is required to be level*.
- The building must be arranged so that three snowploughs can exit at any time when the fourth plough is under repair.
- Doors must be at least 10m wide and 5m high.
- The longest length of any element that can be delivered to site in one piece is 7m.
- Access to the site is limited to 4 months in each year because of weather conditions.
- The elevation and location of the site means that there is high snow and wind loading, including a significant horizontal component from the snow.
- Two boreholes have been drilled on the site, one indicating 200mm of topsoil with rock below, the other indicating 4m of gravel with underlying rock. No groundwater was encountered.

*These elements of the brief require interpretation – see comment later.

Design appraisal

The brief breaks down into a number of themes, each of which must be fully understood and developed.

These are:

- the space requirements and the related need for doors and access
- the requirement for a level garage floor on a sloping site with underlying rock
- high vertical and lateral loads and the implication of load combinations and large doors that may be open in high wind situations
- the limitations of the site in terms of its location, access road and the weather conditions which restrict the length of all structural elements and provide a short time-window for construction.

The starting point for this question must be the layout of the parking bays, taking into account the requirement for egress of the vehicles and the associated location of the doors. As with many questions, these issues are interrelated and nothing else can be done until the layout is established as it determines the overall size of the structure and thus the location and layout of the principal structural elements. Perhaps unusually, in this particular question the brief allows for a variety of plan layouts. Although different plan shapes would not in themselves constitute "distinct alternatives", they may help to provide different structural arrangements, each of which is appropriate for a particular layout.

There is no information in the question relating to the turning circles of the snowploughs however because of the tight site and the requirement for access, in an actual design situation this data would be critical. In the absence of any detailed information, for the purposes of the question I have assumed that the vehicles can turn within a 10m x 10m square (snowploughs are highly manoeuvrable).

Figure 1 shows various possible arrangements each allowing for the movement of any three of the four vehicles (this depends on the assumptions made above regarding to turning circles - if the assumption above is not valid then additional doors will be required for scheme two). It should be apparent at this stage that there are significantly different possible plan shapes depending on how the vehicles are arranged and also that the doors are likely to be a significant factor in the design (particularly in relation to providing lateral stability in an elevation that is predominantly filled with door openings).

There are two elements of the brief that could be open to interpretation (noted with an asterisk in the summary above). The first is the requirement for "no structural elements [to] intrude into this space". The issue here is whether "this space" means the 10m x 10m space required for each vehicle, or the whole building. The second is "the floor of the garage is required to be level". This, it could be argued, relates to the individual space for each plough, or the whole garage floor. This is particularly important from the client's point of view as a level floor will require either a raised floor or excavation (or a combination of both).

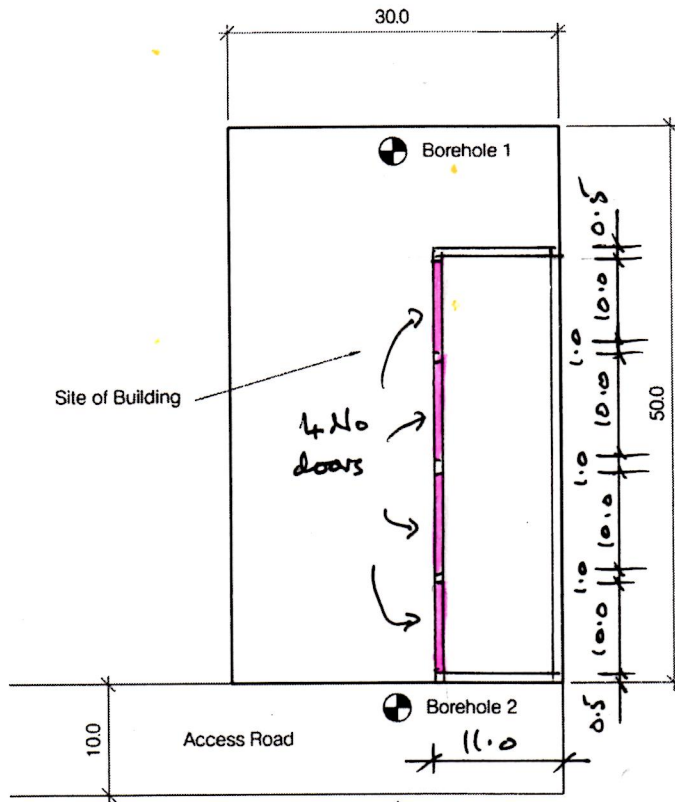

Option 1

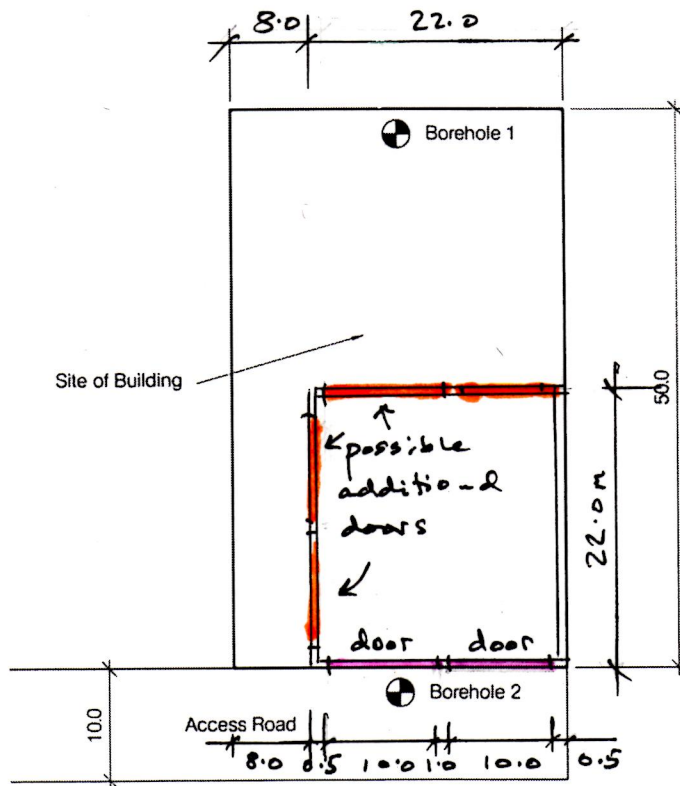

Option 2

PLAN

Figure 1. Possible layouts for snowploughs.

These points could be argued either way, but the first, relating to internal structural elements, is contained in a requirement specifically detailing the space required for each snowplough (client requirement number two). It would therefore seem reasonable to interpret this that no structural elements may intrude into "the space required for a single snow plough" although it would be equally valid to argue that it is obvious no structural element can intrude into the space needed for each individual plough therefore this requirement must mean that no structural elements may intrude into the internal space of the [whole] garage.

Equally the requirement for "the floor of the garage" to be level could be interpreted in one of two ways: the whole garage or the space for each plough. The brief refers to "the garage" and throughout the question the phrase "garage" is singular and refers to the whole building. Therefore I would argue that the whole ground floor slab needs to be at one level.

If one encounters parts of the brief that could be interpreted one way or the other it is sensible to discuss the different potential meanings and the implication on the overall structure and then to decide which interpretation you are going to adopt. You should always do this clearly and logically and not just plump for one interpretation.

Therefore, I am going to conclude that for client requirement number two, "no structural element may intrude into this space", "this space" means each 10 x 10 parking space, and for requirement number four, "the floor of the garage" refers to the singular totality of the garage, i.e. the whole building. It will be evident that both these decisions will have a significant impact on the layout of the building. What would be ill-advised is to glibly pass over any potential ambiguity without discussing the various interpretations!

The structural implication of these decisions is that we can have strategically located internal columns (see figure 4) and that the whole building will need to be at one level, necessitating a raised suspended floor or significant excavation in the gravel/rock, or a combination of both.

The site slopes significantly from one end to the other and the client's brief requires that the floor is level (ie flat/horizontal). This gives various options for the level (ie elevation) of the garage floor but it seems sensible that the floor is at the same level as the access road. This will necessitate a significant amount of the granular material being removed, and at the far end of the site some rock may need to be excavated depending on the proposed footprint.

The borehole logs (see figure 2), shows 4m of granular material with underlying rock at the lower end of the site (borehole 2), and rock near the surface at the upper end (borehole 1), with a shallow layer of topsoil at the upper end of the site. The borehole logs in some way ask more questions than they answer, as the topsoil doesn't appear in borehole two and the gravel doesn't appear in borehole one, so it is not clear how the different soil layers translate across the site. Also from the information supplied, the steep slopes adjacent to the site appear to be gravel! Based on the information supplied and for the purposes of answering examination question, you should make assumptions about the ground conditions at intermediate positions across the site (and ignore the stability of the slopes outside the site (although a comment wouldn't go amiss)), but in practice more investigation would be necessary.

It should be obvious that this building is located in a challenging location with significant snow and wind loads which combined with dominant openings (the doors may need to be open in high winds) creates a relatively complex scenario for load combinations, which must be fully explored in the answer.

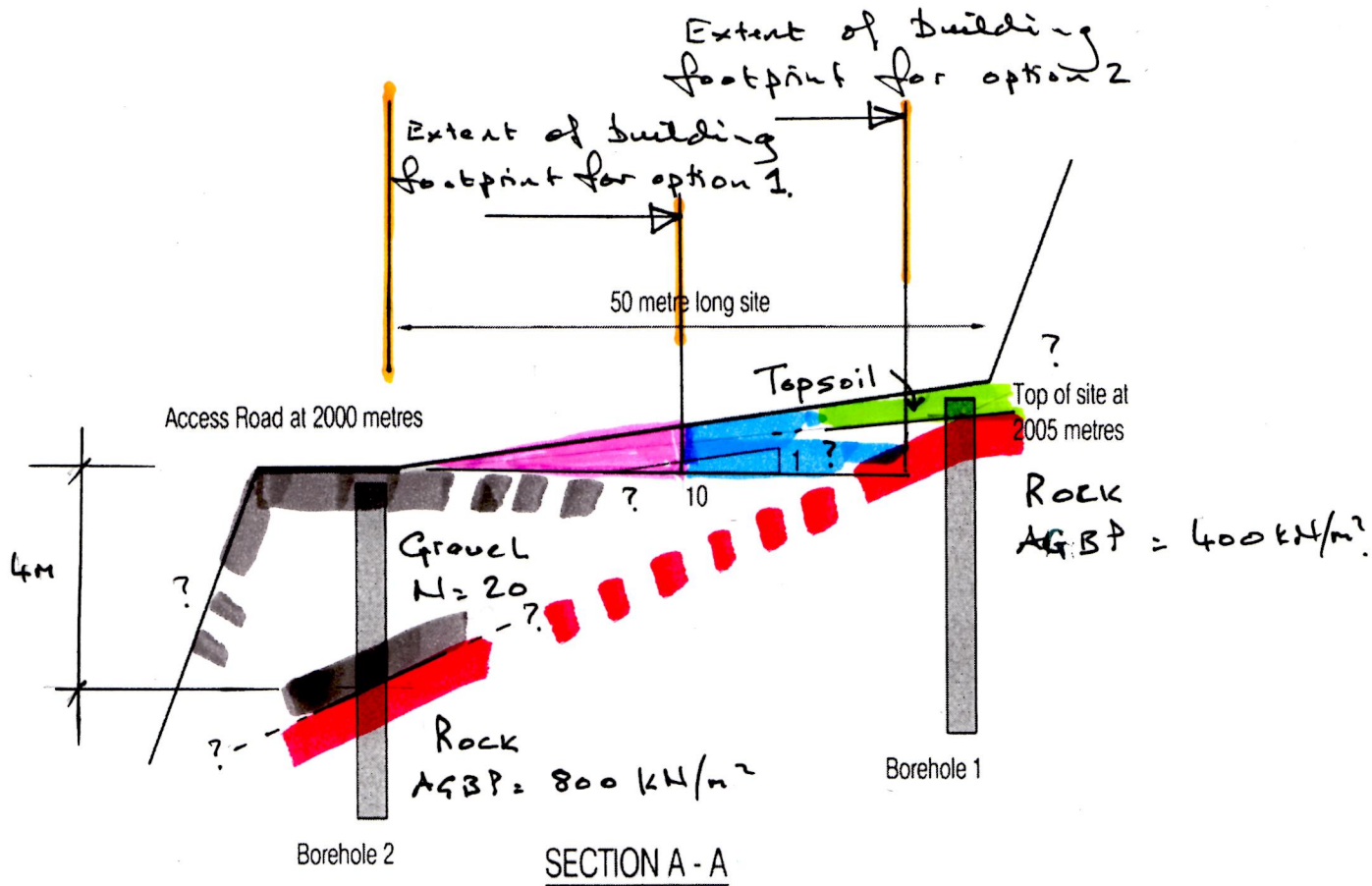

nb. Not to scale.
Exaggerated vertical scale.

Additional site investigation needed to establish changing profile between BH1 & BH2.

Figure 2. Borehole logs, possible profile and likely excavation needed for option 1 & 2.

Possible solutions

The principal items in the brief that will dictate the structural form are the size and orientation of the parking spaces and the commensurate access. The slope of the site and the underlying ground are also important considerations.

The two principal options proposed are therefore: four bays arranged in a square, and four bays arranged in a line (see figure 1). The location of the doors and thus the egress of the vehicles is critically important. The doors need a 10m wide opening.

Steel seems to be the most appropriate structural material taking into account the location, the spans and the need for rapid construction. Simply supported trusses in the roof with columns combined with traditional diagonal bracing would provide one scheme, with portalised frames for the other.

The stability system is an important and related issue. There is no requirement for windows in the building, but the doors are large and there are relatively high lateral loads. Stability could be provided by traditional diagonal bracing in the faces that do not contain doors, and in the door elevations stability could be provided by vertical lattice cantilevers, or portal bracing (concentrated in the vertical strips next to the doors). I've allowed half a metre on either side of the doors to allow for a vertical cantilever or the vertical leg of portal bracing which gives the overall dimensions shown in figures 3 and 4.

It should be apparent that in the arrangement shown in figure 4 there is only 8m for the vehicles to pass the building (no minimum width is given but it seems reasonable to assume that based on the 10 x 10 space required for parking, and the width of the access road, that 8m would be sufficient for the track alongside the building. If it is concluded that 10m is required, then this option is not viable.

Scheme 1

Four garages arranged in a row, each with its own door. The principal advantages of this scheme are easy access to the road and no restrictions if one plough is out of operation and the roof beam spans are minimised. The main disadvantage is the additional ground works as the building goes further back on the site (see figure 2).

This proposal uses 1.0m lattice beams spanning back to front and secondary beams spanning between the principal roof beams with purlins spanning 5.0m. Lattice bracing is provided throughout the roof and vertical bracing is supplied in the three sides that do not contain the doors. Vertical lattice cantilevers form the door openings and provide stability for the door elevation. The five vertical cantilevers are fixed to an RC ground beam forming part of the foundation system.

Scheme 2

Four garages arranged in a square. Two doors adjacent to, and at the same level as, the access road would allow any three out of four vehicles to exit the building (if any one was inoperable) as long as they can turn within a 10x10 square. If this is not the case additional

doors will be required (necessitating additional excavation for the access road). The two door solution would necessitate a retaining wall along the side if the building assuming vehicular access was required to the rear of the site (external storage and maintenance?). The pros and cons are the opposite of scheme one, longer spans balanced by less excavation.

My arrangement uses six lattice portal frames in a 3D grid spanning east-west and north-south, the external frames form the 5m x 10m door openings. Stability is afforded in both directions by the portal action of the frames. The connections at ground level are pinned so as not to impart moment into the foundations. There will be complex details at the central intersection where structural continuity is required in both directions.

The large central column is critical to this scheme but obviously limits the flexibility of the internal space, especially if vehicle are required to manoeuvre inside the building.

Selection.

The scheme 1, shown in figures 1 & 3, is the simplest and stiffest as it has the shortest span for the roof and the more rigid of the two stability systems. This arrangement provides an easy exit from the building for all four vehicles, but the downside is that requires more excavation into the gravel and bedrock to achieve a flat floor. Accordingly this would be my chosen scheme to design in section 2.

Other design factors

There are significant snow loads and the potential for high winds but the building is not particularly large and therefore the loads should be catered for relatively easily. However appropriate combinations of loads must be considered, with snow and wind acting together taking into account the possibility of the large doors being opened during periods of high wind.

The ground floor slab could adequately be supported on the gravel and the main building foundations would best be taken down to the rock.

The brief is clear that no structural element must exceed 7m in length and therefore appropriate positioning of splices is important. It would also seem reasonable that candidates demonstrate their ability to design spliced connections in section 2c of the answer, as the limited length of all structural elements is an important feature of the brief.

The letter

It should be clear from the brief that there is difficult access to the site and challenging weather conditions, both of which are going to impact on the construction of the garage. The scenario presented in the question exacerbates the situation by further limiting the time available for construction. Therefore the letter should present options to the client that would speed up construction. These would include highly planned delivery following just-in-time principles, possible further prefabrication (prefabricated roof, wall and/or floor components), storage of components on-site etc.

It is possible the construction could be split across more than one summer season but it is likely that the client would wish construction to be completed as quickly as possible (in one season).

Depending on the actual scheme proposed, there is likely to be significant ground works, particularly relating to the excavation to provide a level site. Presumably once the plant is on-site work could continue if the access road is blocked, although this of course depends entirely on what happens to surplus excavated material. There is sufficient room on site to allow storage of components.

All these issues give considerable scope for discussion in the letter and a judicious mixture of off-site prefabrication, minimising site work and storage of building components on site would allow for very rapid construction of this building, obviously allowing for ground works and assuming that the necessary redesign and prefabrication could be done in the period before the summer weather window.

Helicopter delivery would not help as the brief limits [all] structural elements to 7m and not just those delivered by road.

It is also possible that depending on the original configuration of the building, a radical redesign aimed specifically at minimising the time needed on site (ie designed for pre-fabrication) could allow the building to be constructed in two months, especially if the brief could be changed to allow for a stepped floor (level for each separate snowplough) as this will dramatically reduce the excavation required. These options should be offered to the client bearing in mind the alternative could be a dramatic extension of the construction programme (extended over more than one summer period). Any redesign would of course take time but this could be scheduled in the preceding winter period. It would also be prudent to mention that the revised meteorological data may require revisiting the loads used in the original design.

There is so much potential in this scenario, the danger would be to get carried away and spend too long on this section. It seems reasonable to suggest that it would be inappropriate to suggest just spreading construction over more than one summer season (which many candidates did!).

Summary

This is an unusual question in that the building size and shape is not predetermined. When combined with some elements of the brief that are open to interpretation it allows for a wide range of potential solutions. However the building itself is a relatively straightforward rectangular industrial shed, albeit with large doors and relatively high vertical and horizontal loads.

Assuming that candidates are not put off by the relatively open nature of the brief it should be possible to propose two structures that are clearly "distinct and viable" and that are simple to design.

There are many areas of discussion contained in section 1b which would allow a very full and detailed answer, which perhaps has the danger of becoming too time-consuming.

Overall this question should allow an experienced candidate a suitable vehicle to demonstrate their design knowledge and experience.

VB = VERTICAL BRACING.

DO = DOOR OPENING.

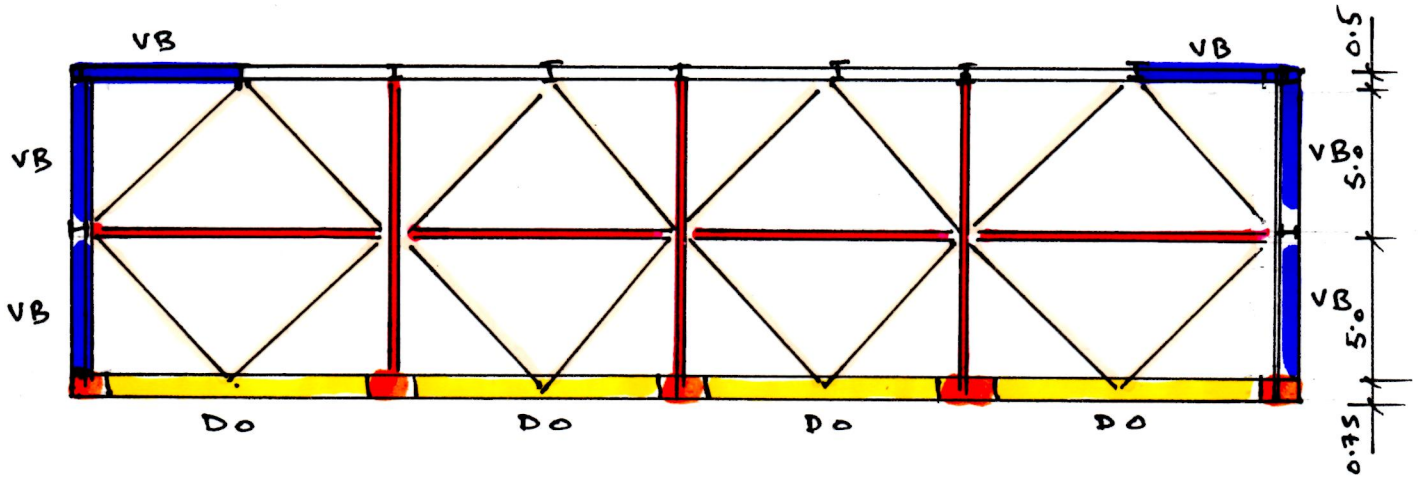

PLAN.

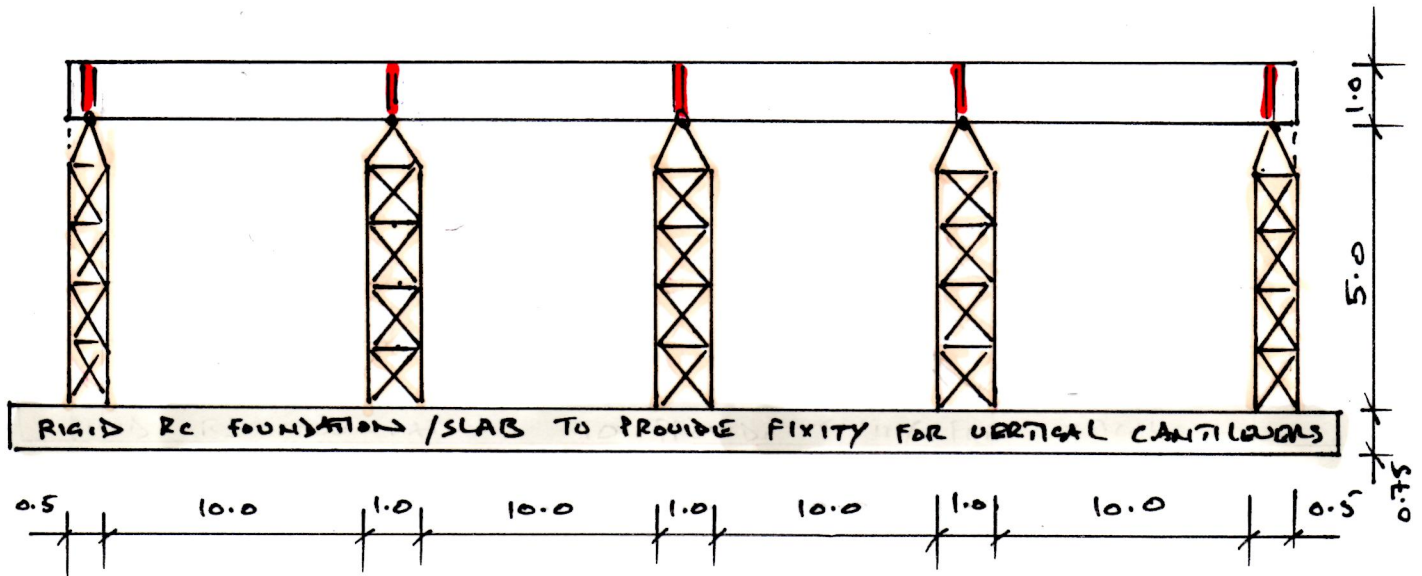

FRONT / DOOR ELEVATION.

NOT TO SCALE.

FIGURE 3.

SCHEME ONE.

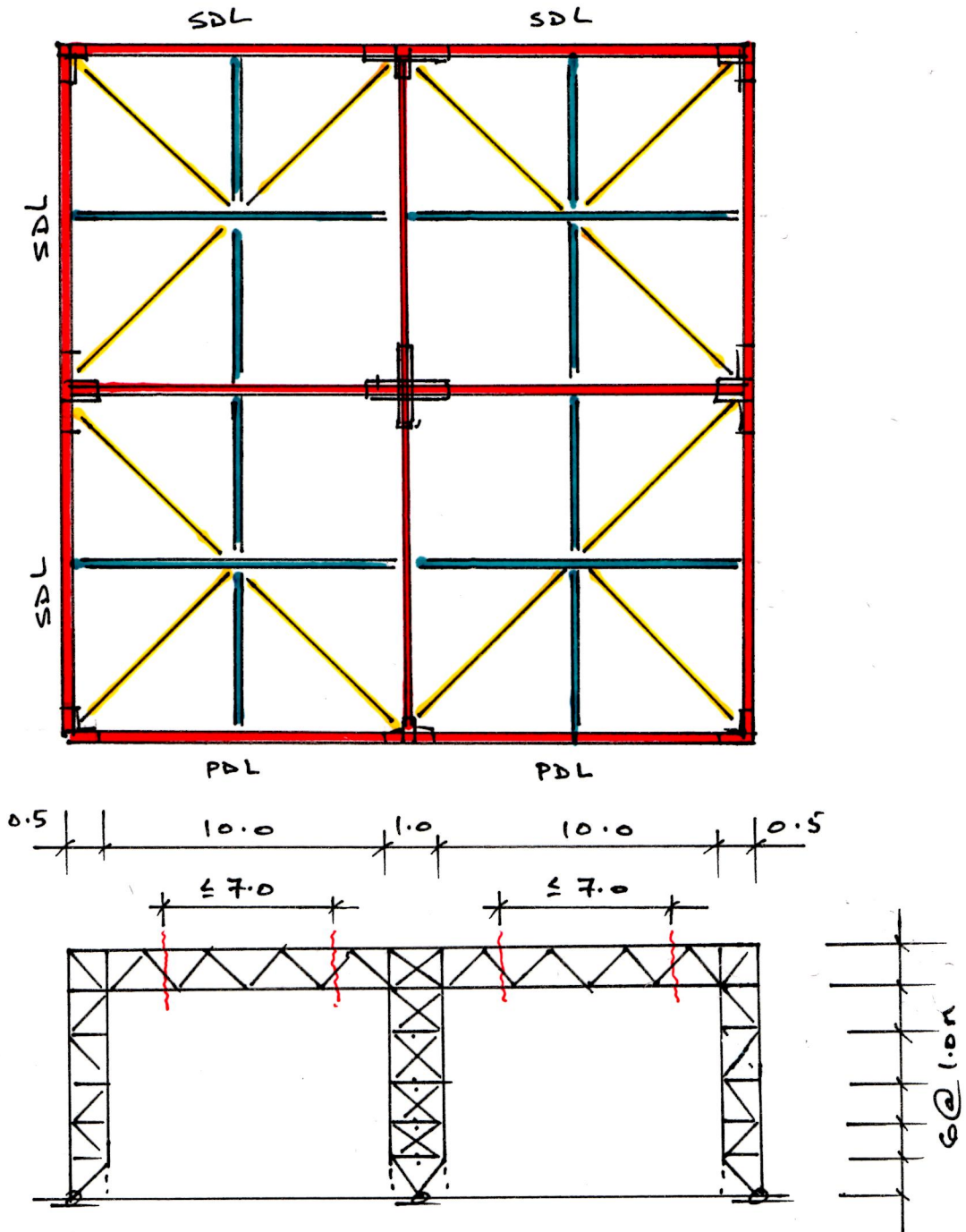

6 No. Lattice portal frames: 3 N-S, 3 E-W.

- PDL Primary door location
- SDL Secondary door location (if required)
- Main lattice portal frame
- Secondary beam
- Bracing
- ~ Splice (max length of element 7m)

FIGURE 4.
SCHEME TWO

The **Institution**
of **Structural**
Engineers

Possible solution to past CM exam question

Question 4 – April 2014

Library building

by Rajavel Inbarajan

The information provided should be seen as an interpretation of the brief and a possible solution to a past question offered by an experienced engineer with knowledge of examiners' expectations (i.e. it's an individual's interpretation of the brief leading to one of a number of possible solutions rather than the definitive "correct" or "model" answer).

Question 4. Library building

Client's requirements

1. A library building is to be built on a site cut into a hillside. See Figure Q4.
2. The building is to be three storeys high. Floor-to-floor heights are to be 4.5m for the lower two storeys and 6.0m for the upper storey.
3. A 40.0m x 20.0m area in the centre of the roof is to be glazed to provide natural light.
4. No columns are permitted within the 44.0m x 24.0m column-free zone indicated in Figure Q4.
5. A minimum fire resistance period of two hours is required for the structural elements.

Imposed loading

6. Floors	7.5kN/m ²
Roof	2.0kN/m ²
Surcharge at top of hill	10.0kN/m ²

Site conditions

7. The site is located in a city centre. Basic wind speed is 40.0m/s based on a 3-second gust; the equivalent mean hourly wind speed is 20.0m/s.
8. Ground conditions:

Ground level – 12.0m	Dense silty sand, $\phi = 35$ degrees
12.0m – 24.0m	Dense sand, N=30
Below 24.0m	Rock, characteristic compressive strength 5000kN/m ²

 Groundwater was encountered at 1.3m below ground level.

Omit from consideration

9. Detail design of lift/elevator shaft and stairs.
Slope stability checks
Roof glazing design

SECTION 1

(50 marks)

- a. Prepare a design appraisal with appropriate sketches indicating two distinct and viable solutions for the proposed structure including foundations. Indicate clearly the functional framing, load transfer and stability aspects of each scheme. Identify the solution you recommend, giving reasons for your choice. (40 marks)
- b. After completion of the design, the client advises that he wants to add a 4.5m deep basement to the building for archive storage. Write a letter to your client explaining the structural implications. (10 marks)

SECTION 2

(50 marks)

For the solution recommended in Section 1(a):

- c. Prepare sufficient design calculations to establish the form and size of all the principal structural elements including the foundations. (20 marks)
- d. Prepare general arrangement plans, sections and elevations to show the dimensions, layout and disposition of the structural elements and critical details for estimating purposes. (20 marks)
- e. Prepare a detailed method statement for the safe construction of the works and an outline programme. (10 marks)

10 Chartered Membership Examination

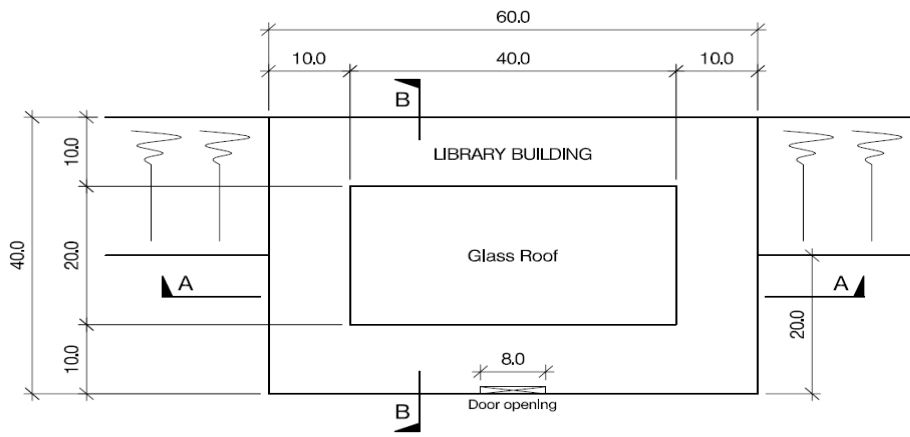

ROOF PLAN

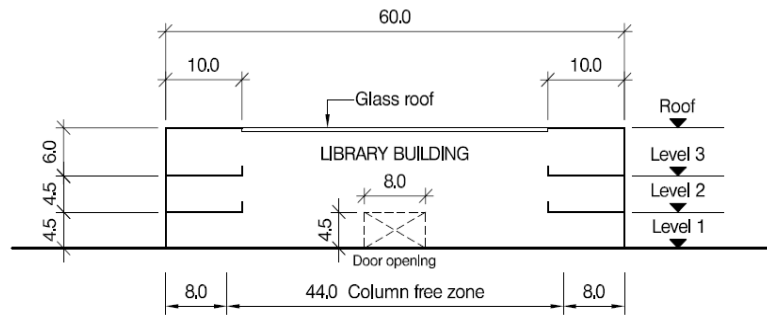

SECTION A - A

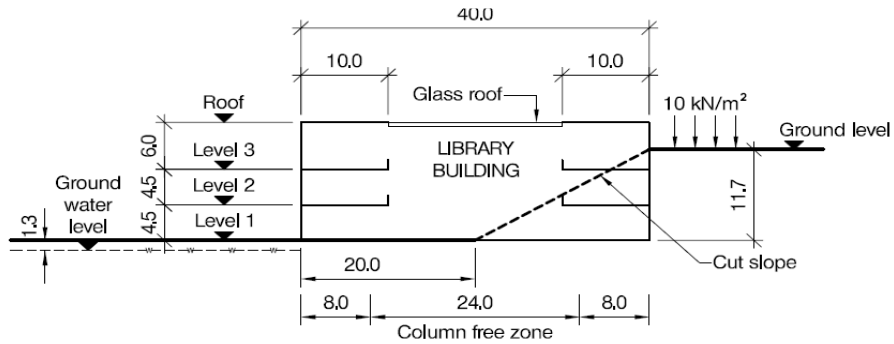

SECTION B - B

NOTE: All dimensions are in metres

FIGURE Q4

Introduction

This question deals with a three-storey Library building to be built by cutting into a hillside in a city centre.

It is quite common that Chartered Membership Examination traditionally tests the candidate's competency in both aspects of geotechnical engineering and structural engineering. This question is such one that demands the understanding of various methods of retaining deep excavation works both in temporary and permanent conditions when constructing a structure especially in sloping hillside in city centre.

Therefore, it is quite natural that the question is daunting for those candidates that lack experience in heavy geotechnical design and construction works involving deep excavations. However, it is definitely not a difficult question for experienced engineers dealing in their practice with the design and construction of earth retaining and supporting structures and concrete/steel structures supporting long span steel roof.

This possible solution is not prepared under examination conditions. It mainly assists in the Chartered Membership Examination preparation with respect to arriving at two distinct and viable solutions as required in Section 1(a) of the question. The annotated sketches provided were drawn in graph papers and then transferred to plain papers to improve the clarity. In the examination, candidates may use the A4 size answer sheets to draw the annotated sketches required to explain their schemes in Section 1(a).

Some guidance is given on the recommendation for scheme selection in Section 1(a).

It also explains the structural implications of adding a basement and assists the candidates in writing a letter to the client as required in Section 1(b).

The issues

- The site is situated in a hillside in a **city centre**.
- The footprint of the building is 60m x 40m.
- Column free area of 44m x 24m in the centre portion is required.
- 40m x 20m area in the centre part of the roof to be glazed to facilitate the entry of natural light into the building.
- The floor to floor height is 4.5m for the lower 2 storeys and 6.0m for the upper storey.
- Minimum fire resistance period is 2-hour for structural elements.

The following is worth noting.

Site boundary

It is expected that the candidate should appreciate the fact that the site is situated in the city centre and as such the working space available outside of the footprint of the building is limited. The question did not demarcate the site boundary and, hence, it is imperative to consider this constraint in the systems selection for earth retaining structure and building foundation in order not to consume more space outside of the footprint of the building.

Locations of lift/elevator shafts and stairs

In fact, the question did not specify the locations of these elements and allow the detailed design of them to be omitted while developing the solution. This is certainly a blessing in disguise for the candidates.

The absence of lift/elevator shafts and stairs locations in this question could be taken as an advantage in arriving at two distinct and viable solutions by altering their locations between schemes. Indeed, the footprint and layout of the library provide flexibility in placing these elements in various locations.

Obviously, albeit the lateral load effect due to the earth needs to be carefully tackled in the design and construction of the library in the hillside during temporary and permanent stages, the candidates should feel having some “quantum of solace” and thank the somewhat inherent architectural symmetry that could be achieved in their solution.

Overturning and sliding should be prevented to maintain the stability of the structure both in temporary and permanent conditions. These strong elements partly could contribute in resisting the lateral earth and surcharge forces.

Site conditions

The wind detail is provided in terms of basic wind speed (40m/s) on a 3 second gust and equivalent mean hourly wind speed (20m/s). The candidate has the liberty to choose the basic wind speed or mean hourly wind speed values given in the question based on their local practice as its varies from country to country.

Ground conditions varies as follows;

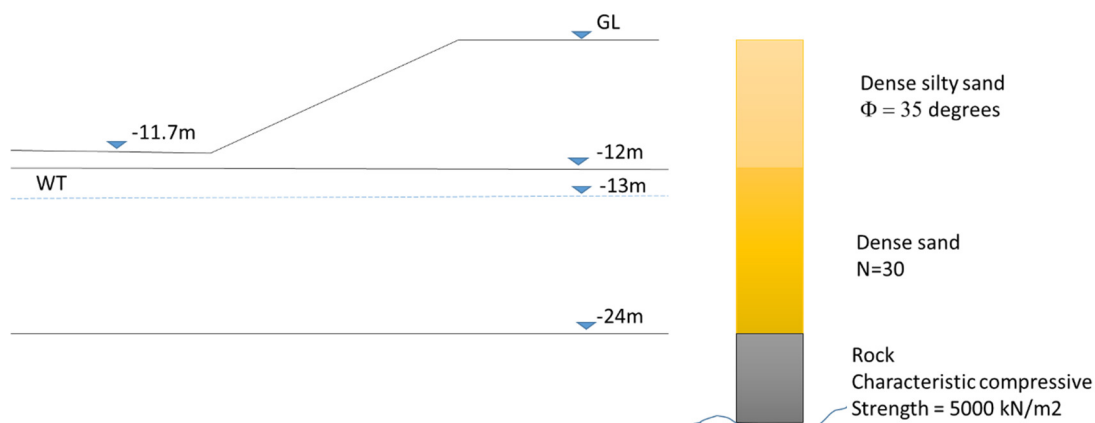

It is required to work out the required geotechnical parameters based on the details given for the site conditions.

- The ground water level has been taken as shown in Section B-B (at RL= -13.0m) in the question though the “Site conditions” mentions that it is 1.3m below ground level, which is the top of the hillside as denoted in the same Section B-B.
- Density of the dense silty sand could be taken as 19 kN/m³.
- Active earth pressure coefficient (K_a) and earth pressure coefficient at rest (K_0) can be calculated based on the ϕ (=35 degrees) value given.
- The safe allowable bearing pressure of the rock strata could be calculated using a factor of safety (FOS) of 3.0.

In this question, the lateral earth force is very much higher than the lateral wind force. Candidate should appreciate this fact and demonstrate their understanding on this regard.

The methods of excavation of slope and the related temporary works needed to retain the earth should be explained with simple sketches to demonstrate the understanding of earth retaining and stabilising systems.

Possible solution

The question requires two distinct and viable solutions. It is important that the candidates should understand the real meaning of this requirements for scoring good marks in the Chartered Membership Examination.

“Distinct” in the context of the Chartered Membership Examination does not merely mean using different materials for the same layout. Viable means that the structure can be safely built.

In fact, it should be looked into further in achieving the two schemes in the following ways in the case this question.

- Adopting different load paths with dissimilar construction methods for earth retaining and supporting system, floor and roof.
- Choosing different floor systems for floors and roof with concrete and steel.
- Selecting different types of truss systems to support the glass roof.
- Adopting different foundation systems such as cast in-situ bored pile and raft foundation. (Note – Precast RC driven pile system is not preferable in city centre locations.)
- Selecting different layout with dissimilar column and wall spacing without impinging on the functional requirements and client’s brief.

In fact, many distinct and viable solutions are possible for this question when considering the above features with different combinations of systems, load transfers and construction methods.

The following distinct and viable schemes are proposed as solution to this question.

Scheme 1- Cast in-situ reinforced concrete building on raft foundation

The following depicts the structural system selected for Scheme 1.

Conventional reinforced concrete frame consists of slabs, beams, columns and walls connected to raft foundation forms the structure except for the glass roof area that utilises steel trusses spaced at 4m interval and connected to the concrete structure at roof level to support the glass.

In general, 2m cantilever beams around the atrium with 8m/3m back spans are connected to columns/walls in Level 2, 3 and roof. In general, the column/wall spacing is set as 8m surrounding the atrium area to facilitate the load transfer.

Triangular shaped steel tubular trusses are used to support the glass roof in the atrium. The truss has two top chords and one bottom chord connected by inclined tubular web members. This arrangement gives aesthetically pleasing appearance inside the building and make it possible to install glass panels with ease.

The locations of lift/elevator shafts (middle of back and front sides) and stairwells (back side corners) are positioned in the longer side of the building to facilitate the lateral load transfer in this scheme.

Permanent secant pile walls are used to retain the lateral load due to surcharge and earth formed by cutting the slope between Ground Level and Level 1. Secant pile walls are to be permanent and to be socketed into the rock to arrest sliding, overturning and also to prevent deep seated failures due to extreme conditions created in the surroundings by future construction activities. In permanent condition, floors at Level 2 and Level 3 prop the secant pile walls. Therefore, it is necessary to consider the rest condition in the design of the secant pile wall in permanent condition and the related lateral forces should be resisted by the structure. Hence, K_0 should be used to calculate the lateral forces created by earth and surcharge pressures at permanent conditions. However, it is required to consider the temporary stage too in active condition during excavation of the slope. Hence, it is very important to maintain the stability of the structure and the excavated hillside during both temporary and permanent stages. In-situ flush should be provided to the secant pile walls to get a smooth surface and to receive waterproofing to prevent dampness and vapour in real conditions.

Raft foundation is proposed to safely transfer the loads to ground and to control the differential settlement between the front and back side of the building though front side of the building can rest on isolated or combined footings. The bottom of the footing level could be placed just above the water table in general when adopting raft foundation except in lift well areas. Since the water table is very shallow, the safe bearing capacity should be limited to 5N. In this respect, raft foundation resting on well compacted ground is preferred over isolated footing. The centre part at Level 1 could have slab on grade resting on well compacted ground.

Vertical loads transfer

The gravitational forces arising from dead load, superimposed dead load and live load are supported on slabs that transfer the loads to reinforced concrete beams and walls through bending and shear actions. The beams in turn transfer the loads to reinforced concrete columns and walls, generally spaced at 8m, through bending and shear actions.

The glass roof is supported by steel trusses spaced at 4.0m. These steel trusses transfer the dead load, superimposed dead load and live load to reinforced concrete cantilever beams/beams in the roof through bending and shear actions. These cantilever beams transfer the loads to reinforced concrete columns through bending and shear actions.

The columns and walls via bending and shear actions transfer the loads to reinforced concrete raft foundation that transfer the loads to the ground by bearing action.

Lateral loads transfer

Lateral loads such as earth load and wind load are generally resisted by the diaphragm actions of the floors and then get transferred to vertical elements such as walls and columns through horizontal bending and shear actions.

A glance on the layout and sections given in the question reveals that the lateral earth pressure dominates over the wind pressure by many fold. Therefore, it is necessary to integrate the secant pile wall with the floors permanently to transfer the lateral earth and surcharge loads. The secant pile wall transfers the lateral earth and surcharge loads by one way action vertically upward and downward between the floors through bending and shear actions. The floors in turn transfer the loads particularly to rigid walls through diaphragm action and in combination with horizontal bending and shear actions.

Wind load is resisted by façade elements and get transferred to floors and roof by bending and shear actions. Diaphragm action of the floors and roof transfers the load to columns and walls through bending and shear actions.

Walls and columns then transfer the lateral loads through bending and shear actions to raft foundation that transfers the loads to the ground by bearing action and friction.

Robustness and stability

All the beam and column connections should be monolithic/continuous to achieve the robustness and stability. The building floors should be connected to secant pile wall.

Durability/Fire resistance

The concrete cover should be selected in such a way to comply with the durability and fire resistance for 2-hour.

Annotated sketches depicting the layout and section complying with the client's brief are shown below.

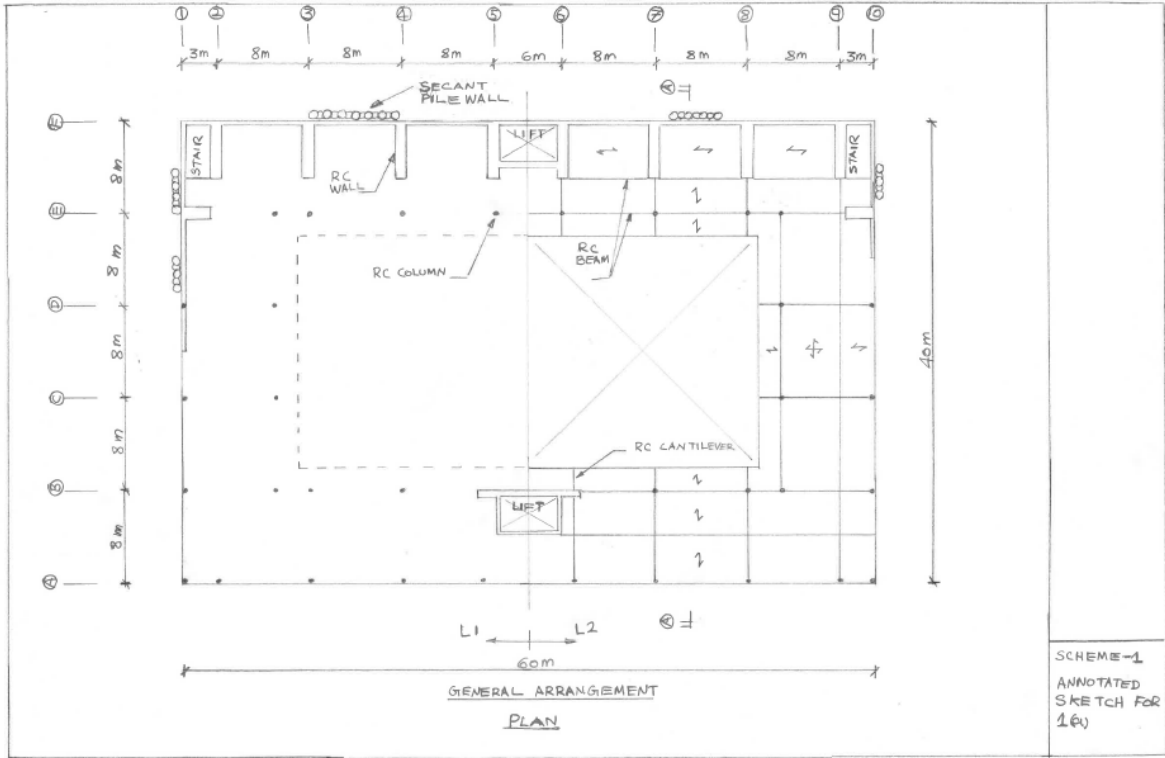

SCHEME-1
ANNOTATED
SKETCH FOR
1(a)

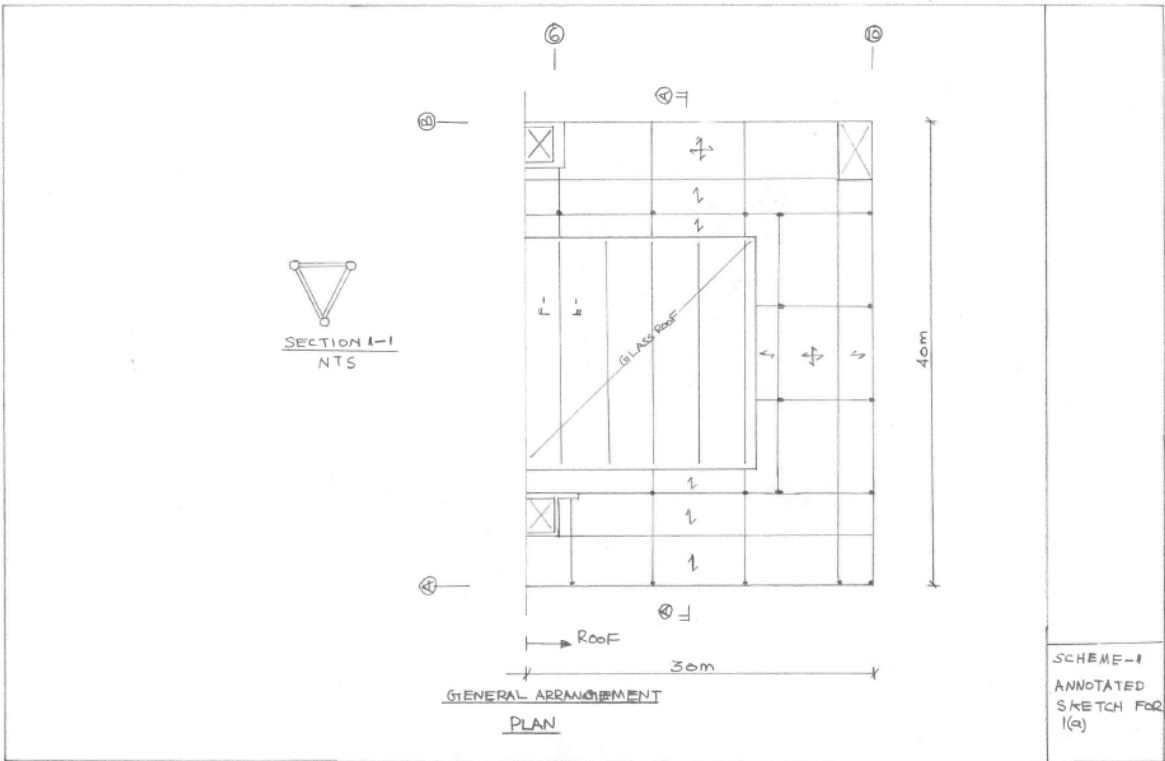

SCHEME-1
ANNOTATED
SKETCH FOR
1(a)

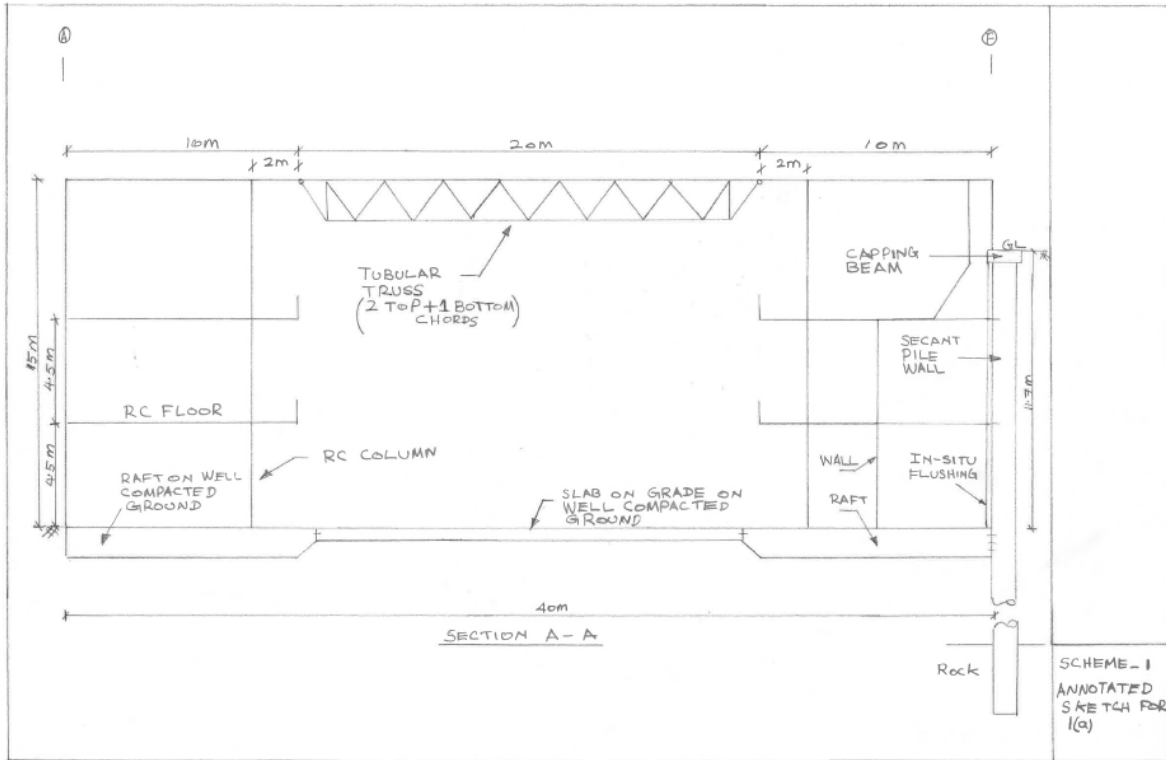

SCHEME - I
 ANNOTATED
 SKETCH FOR
 1(a)

Scheme 2- Steel building on piled foundation

The following depicts the structural system selected for Scheme 2.

Steel composite floor is selected for Level 2 to Roof except for the glass roof area that utilises steel trusses spaced at 5m interval connected to the concrete structure at roof level to support the glass.

In general, 2m cantilever steel beams around the atrium with 8m/5m back spans are connected to steel columns/reinforced concrete walls in Level 2 and 3. The columns surrounding the atrium are hung from the steel trusses at roof. In general, the column/wall spacing is set as 5m to facilitate the load transfer.

The steel trusses spaced at 5m are supported on reinforced concrete columns in the back side and on braced double steel columns on the front side. It is required to provide 8m wide and 4.5m high door opening in the front side. Therefore, it is necessary to provide a 10m long transfer truss at Level 2 above the door opening below.

Steel trusses are used to support the roof, glass over atrium and the tension loads transferred from Level 2 and 3 below through steel hanger columns.

The locations of lift/elevator/stairwell are positioned in the middle of shorter sides of the building in this scheme.

Steel sheet pile walls are used to retain the surcharge load and earth formed by cutting the slope between Ground Level and Level 1 in temporary condition. Reinforced concrete retaining walls with buttress walls are used to retain the lateral loads generated by earth and surcharge pressures in permanent condition. Therefore, it is necessary to consider the rest condition in the design of the retaining wall and buttress wall. Hence, K_0 should be used to calculate the lateral forces created by earth and surcharge pressures at permanent conditions. However, it is required to consider the temporary stage too in active condition during excavation of the slope. Hence, it is very important to maintain the stability of the structure and the excavated hillside during both temporary and permanent stages. The retaining wall should be provided with waterproofing to prevent dampness and vapour in real conditions.

Cast in-situ bored pile foundation is proposed to safely transfer the loads to ground and to control the differential settlement between the front and back side of the building and to prevent sliding and overturning. Piles are to be socketed into the rock to prevent deep seated failures due to extreme conditions created in the surroundings by future construction activities. The centre part at Level 1 could have slab on grade resting on well compacted ground.

Vertical loads transfer

The gravitational forces arising from dead load, superimposed dead load and live load are supported on slabs that transfer the loads to secondary steel beams and walls through bending and shear actions. Those secondary steel beams in turn transfer the loads to primary steel beams connected to steel columns and reinforced concrete walls, generally spaced at 5m, through bending and shear actions. The steel columns transfer the loads upward in tension to steel trusses spaced at 5m at roof level. The glass roof is supported by steel trusses.

These steel trusses transfer the dead load, superimposed dead load and live load to reinforced concrete columns in the back side and steel columns in the front side through bending and shear actions.

The columns and walls then transfer the loads to reinforced concrete pile caps through bending and shear actions. Pile caps then transfer the loads to cast in-situ bored piles through bending and shear actions. The piles transfer the loads to ground via friction and end bearing.

Lateral loads transfer

The reinforced concrete retaining walls transfers the lateral earth and surcharge loads horizontally by one way action between buttress walls through bending and shear actions.

Wind load is resisted by façade elements and get transferred to floors, roof and vertical bracing by bending and shear actions. Diaphragm action of the floors and roof transfers the load to columns, walls and vertical bracing through bending and shear actions.

Walls, columns and vertical bracings then transfer the lateral loads through bending and shear actions to pile caps. Pile caps then transfer the loads to cast in-situ bored piles through bending and shear actions. The piles transfer the loads to ground via friction and end bearing.

Robustness and stability

All the beam and column connections should be moment connections to achieve robustness and stability. Core walls and vertical bracing contribute to the stability and improve the robustness.

Durability/Fire resistance

All the concrete elements should have sufficient cover to satisfy the durability requirements and fire resistance requirement for 2-hour fire rating. All the structural steel elements should be provided with suitable fire coating to withstand the 2-hour fire rating.

Annotated sketches depicting the layout and section complying with the client's brief are shown below.

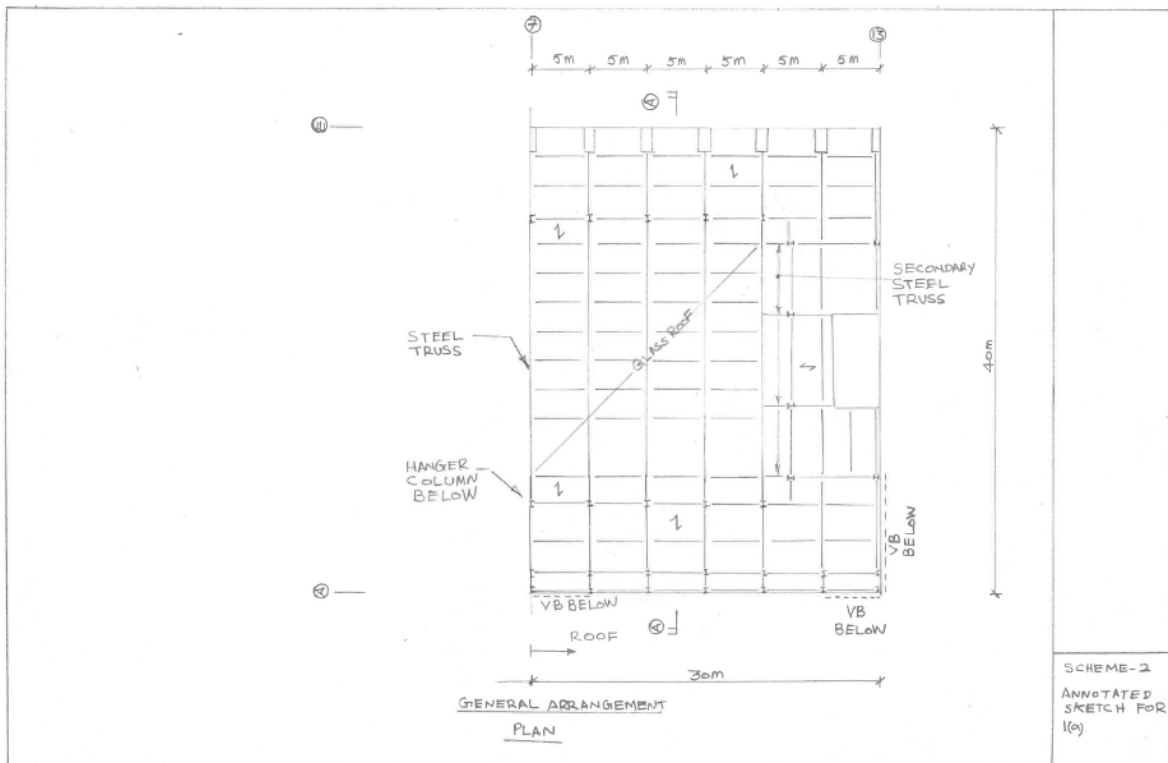
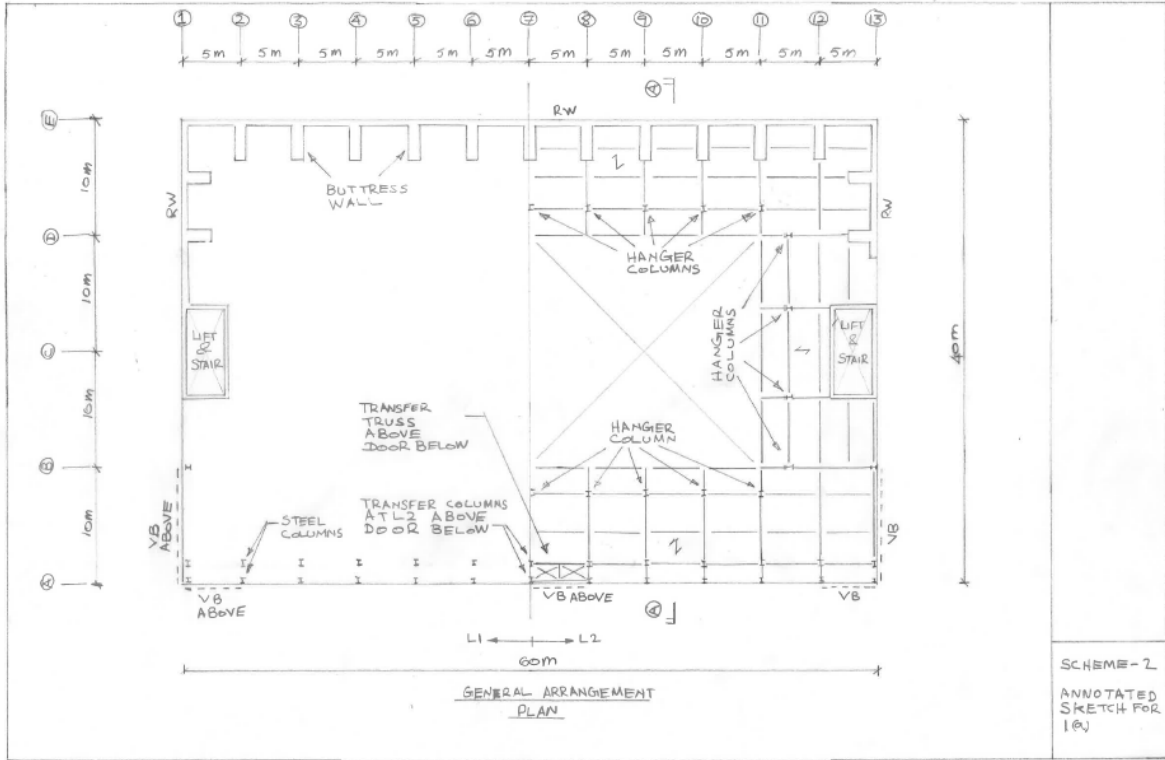

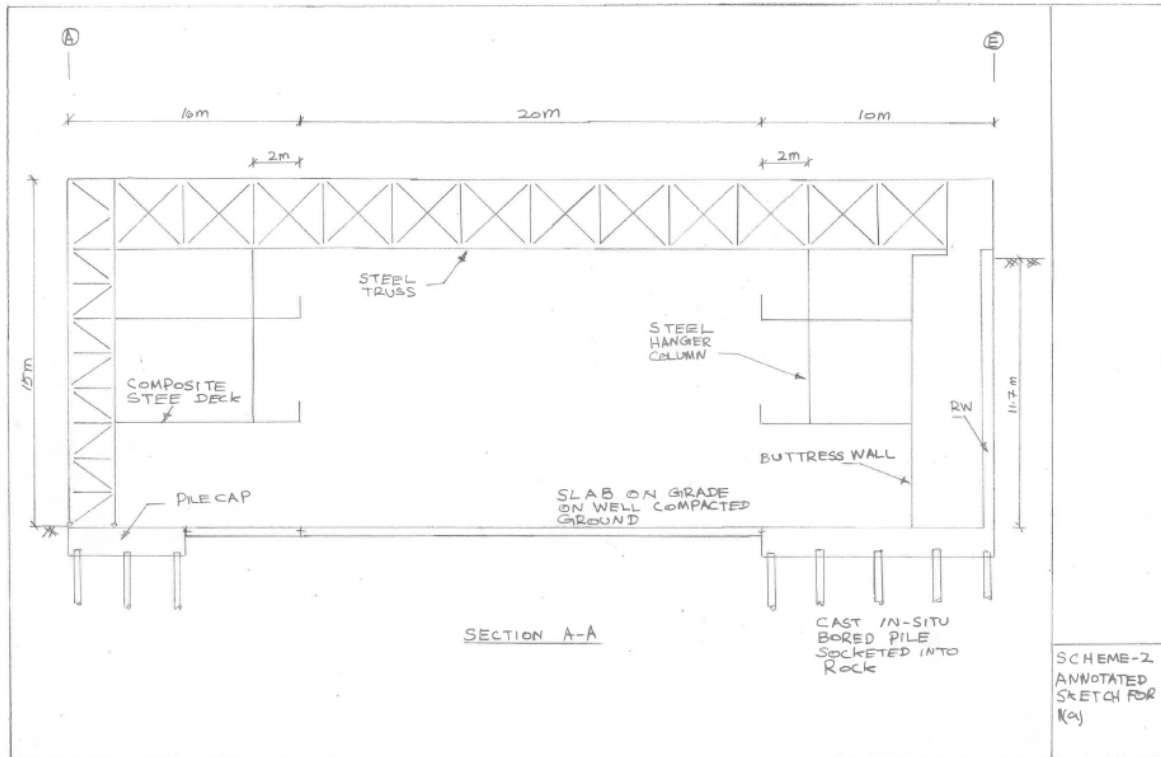

Selection of scheme

The following salient features could appropriately be considered in recommending the scheme considering the pros and cons of each scheme,

Economy	Buildability	Safety	Robustness	Durability
Site constraints	Speed of construction	Aesthetic	Acoustics	Thermal mass
Sustainability	Vibration	Fire resistance		

Letter

The letter tests the competency of the candidates in dealing with a design change situation after the completion of the detailed design as come across in real practice. It should be written effectively to communicate the structural implications to a non-technical reader.

The design change situation in this question is incorporating a 4.5m deep basement for archive storage.

The following points cite the consequences of adding a basement and can be used to formulate the letter for this question.

- The addition of the 4.5m deep basement would seriously affect the design and construction of the library.
- The lateral earth pressure acting on the temporary and permanent retaining structure would drastically be increased.

- The foundation design would have to be revised due to the increased vertical load, hydrostatic uplift and lateral loads.
- The design of the structure has to be revised. The other key issue to be dealt with is the need for waterproofing.
- The time required for the redesign and construction would significantly increase.
- The cost of the project would increase.

It is worth noting the following,

- The structural implications could be explained using appropriate sketches in this part of the question.
- If the structural implications of the design change requirement seems trivial to the candidate then it implies that he/she has disregarded an essential part of the question.
- The letter should give importance to explain the structural aspects of the design change requirement and not emphasise on the business aspect related to additional fee.

Summary

This question is an easy and straight forward question for those who possess good experience in the design and construction of concrete structures, steel structures and earth retaining and stabilising systems.

Arriving at two distinct and viable solution becomes possible when the inherent characteristics of these systems are suitably utilised and combined in the appraisal to deal with different materials, load paths and construction methods.

Rigid and less rigid floor systems used in Scheme 1 and Scheme 2 respectively with the adoption of different earth retaining systems for these schemes alter the load paths when transferring the lateral and vertical loads.

Varying the positions of the lift/elevator shafts and stairs is vital too in the appraisal in arriving at two distinct and viable solutions. As a marking examiner of this question, I noticed that many candidates did not explore this opportunity in their favour. They faced difficulties in providing satisfactory solution in the examination.

It is also important to demonstrate in the answer that the stability of the structure at temporary and permanent conditions is maintained. Stability checks on over turning and sliding must be provided based on the elements sizes obtained.

An experienced graduate engineer that can envisage the large lateral forces created by ground retaining and demonstrate his/her competency on the methods of resisting them in temporary and permanent conditions has a very good chance of passing the exam, if he/she is also capable in arriving at two distinct and viable solution without violating the clients' brief.

The **Institution**
of **Structural**
Engineers

Possible solution to past CM examination question

Question 5 - April 2014

Cliff-top house

by Bob Wilson

The information provided should be seen as an interpretation of the brief and a possible solution to a past question offered by an experienced engineer with knowledge of the examiners' expectations (i.e. it's an individual's interpretation of the brief leading to one of a number of possible solutions rather than the definitive "correct" or "model" answer).

Question 5. Cliff-top House

Client's requirements

1. A new house built on a cliff top overlooking the sea. See Figure Q5.
2. The house is to be circular in plan and is to have four upper storeys and a basement. The top storey is to be 8.0m diameter with views in all directions; all other storeys are 5.0m diameter. 1.5m wide balconies looking towards the sea are required at levels two and three.
3. There is to be a 3.5m diameter x 1.5m deep circular swimming pool in the basement.
4. No internal columns are allowed above level four.
5. The site is at the end of a 1.5km long, narrow, winding lane.

Imposed loading

- | | |
|-----------|----------------------|
| 6. Floors | 1.5kN/m ² |
| Balconies | 1.5kN/m ² |
| Roof | 1.5kN/m ² |
- Horizontal loading on balcony balustrade 0.75kN/m at 1.1m above balcony level.

Site conditions

7. The site is located in open countryside. Basic wind speed is 52.0m/s based on a 3-second gust; the equivalent mean hourly wind speed is 26.0m/s.
8. Ground conditions:

Ground level – 0.5m	Made ground
0.5m - depth	Fissured sandstone, allowable safe bearing pressure 1500kN/m ²
Groundwater is not present	

Omit from consideration

9. Detail design of stairs.

SECTION 1

(50 marks)

- a. Prepare a design appraisal with appropriate sketches indicating two distinct and viable solutions for the proposed structure including foundations. Indicate clearly the functional framing, load transfer and stability aspects of each scheme. Identify the solution you recommend, giving reasons for your choice. (40 marks)
- b. The design has been completed and initial site works begun when the clients announce that they are expecting twins and would like to add an additional 5.0m diameter storey below the 8.0m diameter storey. Write a letter to the clients advising them of the structural implications. (10 marks)

SECTION 2

(50 marks)

For the solution recommended in Section 1(a):

- c. Prepare sufficient design calculations to establish the form and size of all the principal structural elements including the foundations. (20 marks)
- d. Prepare general arrangement plans, sections and elevations to show the dimensions, layout and disposition of the structural elements and critical details for estimating purposes. (20 marks)
- e. Prepare a detailed method statement for the safe construction of the building and an outline programme. (10 marks)

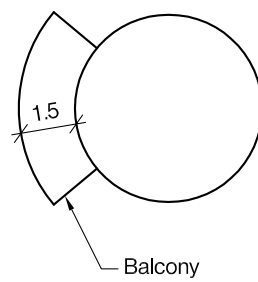
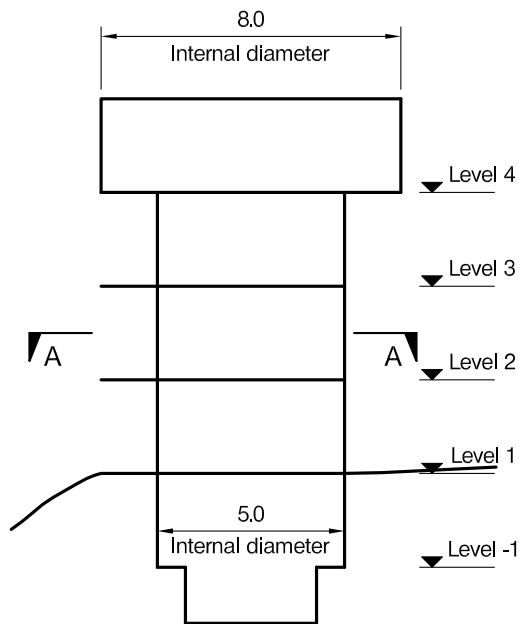
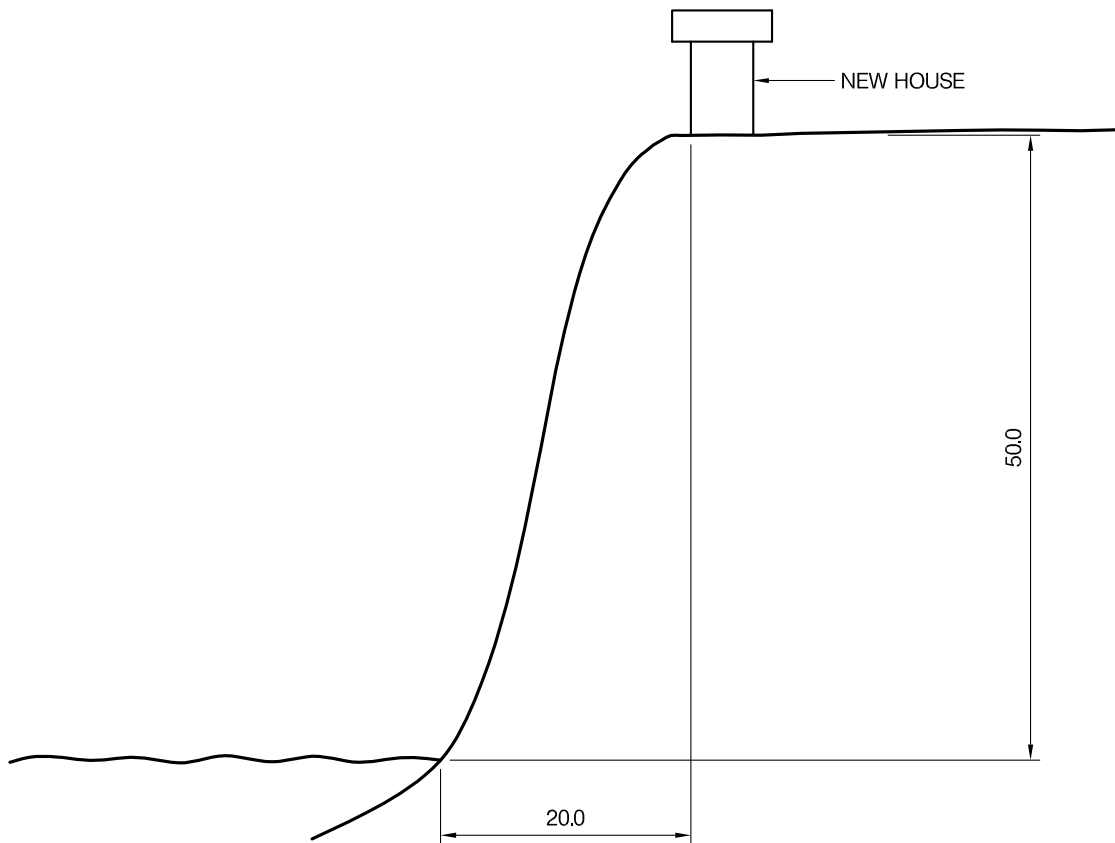

SECTION A - A

SECTION

NOTE: All dimensions are in metres

FIGURE Q5

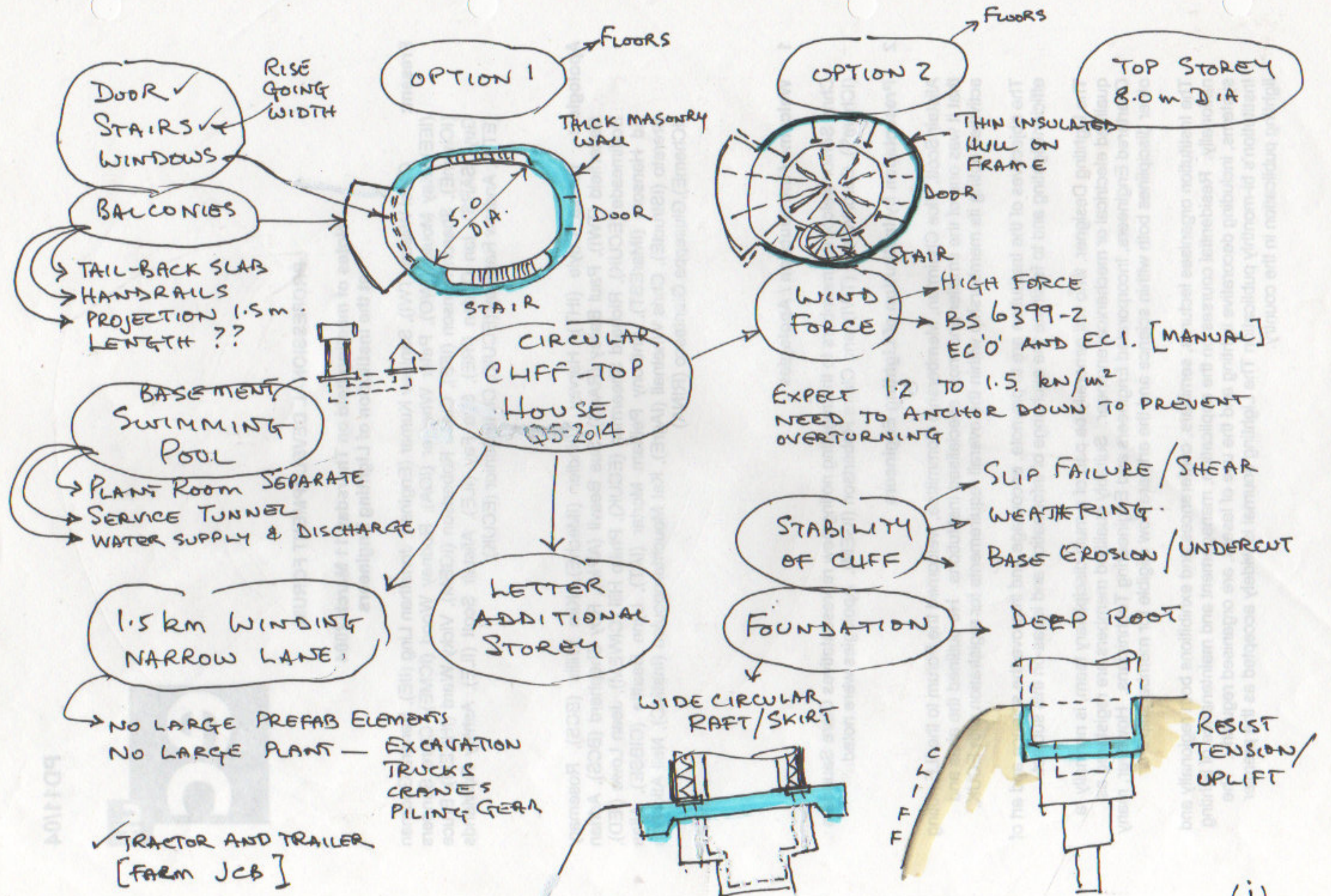

INITIAL MIND.MAP FOR Q5-2014

TOPICS THAT POSSIBLY NEED RESEARCH AND PREPARATION - Q5-2014

- STAIRS & STAIRWAYS — RISE, GOING, STEPS IN A FLIGHT, WIDTH, ^{CLEAR} HEIGHT
— INSIDE THE WALL, SPIRAL
- WATERPROOFING SWIMMING POOL
- USE OF HELICOPTER FOR DELIVERIES / ERECTION
- STORM-PROOF WINDOWS ON TOP STOREY — INCLUDING ADDITIONAL ROOM FOR TWINS.
- CLIFF STABILITY AND PROTECTION — ROCK ANCHORS — FISSURED SANDSTONE
— SURFACE SHELL
— STORM WAVE PROTECTION
— SAND ACCRETION WITH GROYNES
— ROCK ARMOURING
— CONCRETE-UNIT ARMOURING.
- WIND PRESSURE / FORCE — TOP OF CLIFF
— EDGE OF SEASIDE
— PLUCKING OF CLADDING
— WINDOW AIR / WATER TIGHTNESS
— UPLIFT ON BALCONIES
— TIE DOWN TO PREVENT UPLIFT / OVERTURNING
- INSULATED WALL AND ROOF PANELS

DESIGN / CALCULATION AREAS THAT MAY NEED RESEARCH Q5-2014

- FOUNDATIONS WITHIN FISSURED SANDSTONE
 - RESISTING UPLIFT - GROUND ANCHORS
 - RESISTING MOMENT
 - HOW TO EXCAVATE - FISSURES OPENING
 - GROUTING FISSURES
 - "PALI RADICE"
- STONE MASONRY
 - GENERAL STRESSING UNDER GRAVITY / WIND LOAD.
 - LOCAL STRESSING UNDER BALCONIES AND AT CHANGES IN WALL THICKNESS
- BALCONIES AND RADIAL FLOORS
- RADIAL ROOF WITH WIND UPLIFT - EFFECT OF CIRCUMFERENTIAL GLAZING
- ALTERNATIVE HULL-FRAME STRUCTURE
 - BATTENED STANCHIONS.
 - H.D. BOLTS
 - STRESSED-SKIN HULL
 - DIAGRID HULL

To be fair Question 5-2014, a cliff-top House, was not a popular question; so I decided that I would try the "date". Uninformed, shallow, timid or hesitant candidates should, probably, pass this question by! I did not attempt to produce my answers within the seven or so hours available in the examination - I just wanted to arrive at a credible solution! If challenged to produce an examination answer I should have to crash through many interesting side lines, keeping very purposefully to the essence of "House", "Circular", "Access to the site" and "Basic viability".

Ignore such side lines as "cliff stability", "undermining by the sea", any availability of large machinery and modern technology in order to focus on:

- Wind forces on the building at the top of a 50.0m high cliff.
- Basic viability such as stairs to each floor; insulation and weather-tightness; leading to wall thickness and the geometry of a circular domestic tower with plunge pool in a cellar.
- The constraint placed upon accessibility - a long narrow lane! Surely the new Client will want the access to be improved!

Once you constrain yourself to these three "problems" the answer becomes credibly manageable!

As I have never worked on anything like this before I needed to explore the brief. In this case I used small physical models. One reason for doing so was because of the CD presentation. One would not have this facility in the exam room, though many projects at this stage do in fact use models, some a great deal rougher than the ones I made. However, a similar exploration could be made by ~~a competent~~ with freehand sketches; See Figures 1 and 2.

Alternatively, the candidate can try and communicate by word:

"The main body of the tower is composed of two concentric rings of masonry the inner one with a clear internal diameter of 5.0m. The outer wall has an external diameter of 8.0m. With both walls only 225mm thick [the thickness of a concrete block or brick] a cavity 1000 wide is formed. This is just enough for a stairway. Access between the floors is not mentioned in the Question but is clearly part of the viability of the scheme."

Clearly the weakness of either of these singular methods is that one can forget to mention important features. Probably the answer is to use both methods as appropriate.

OPTION 1

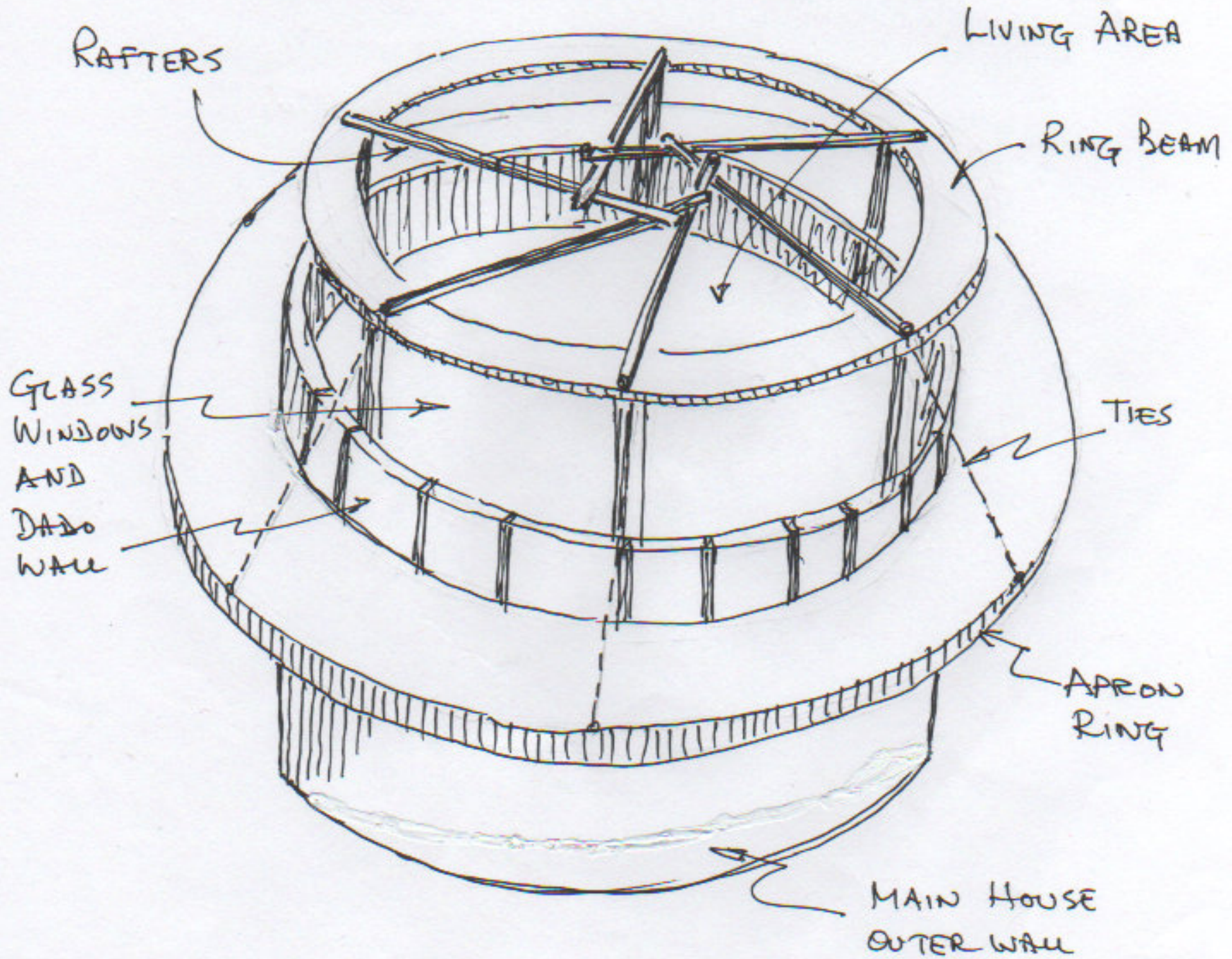
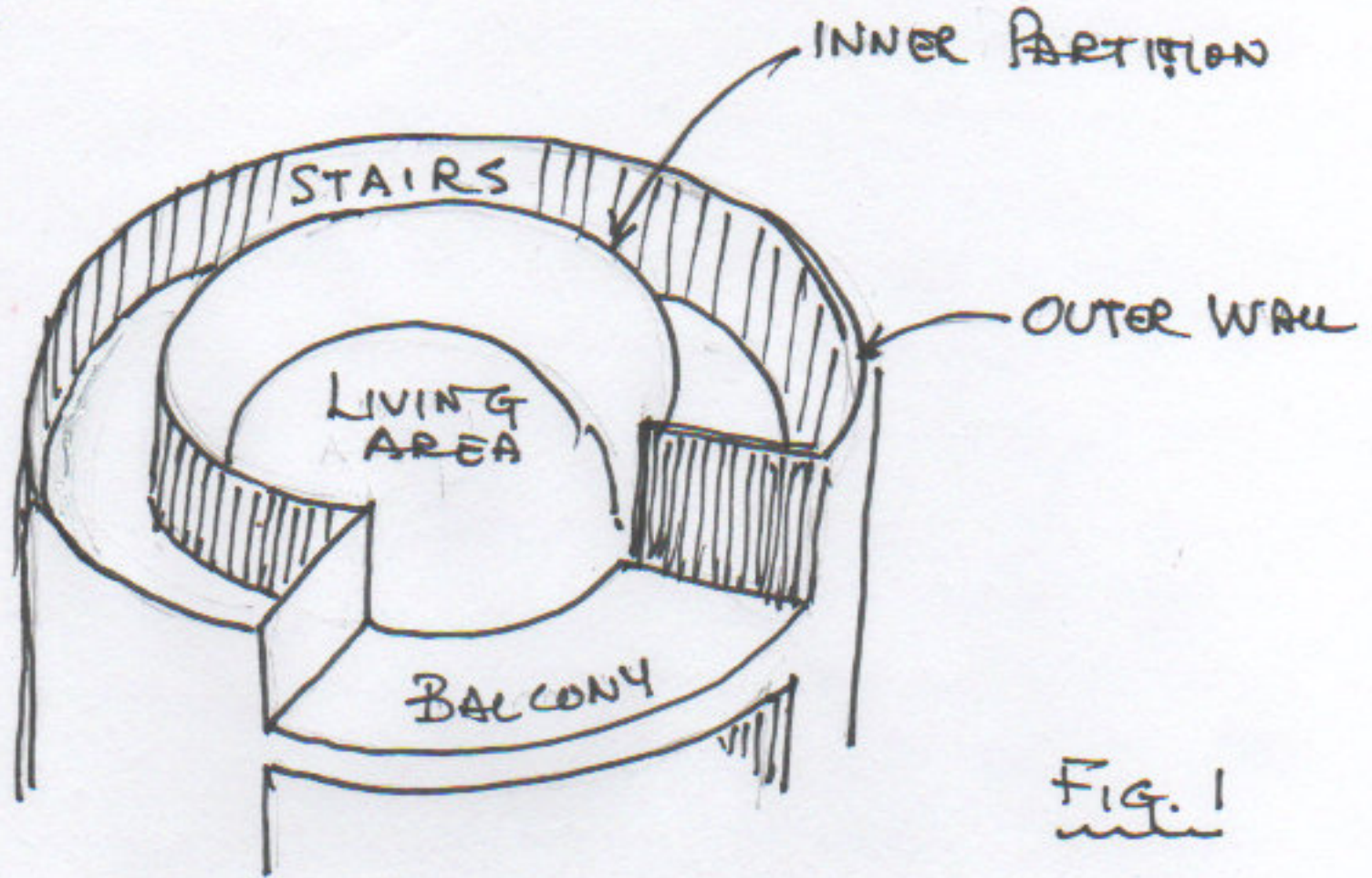

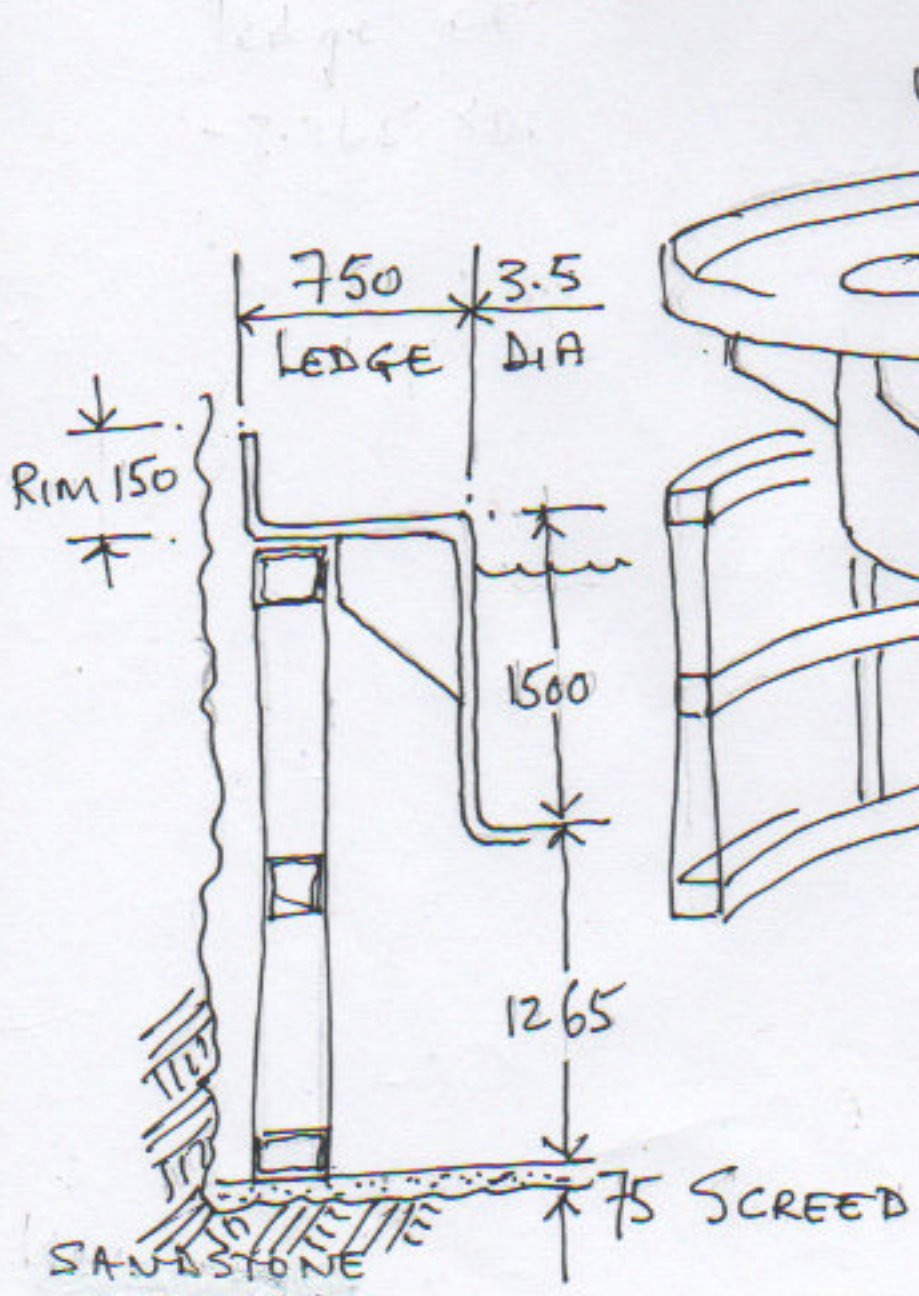
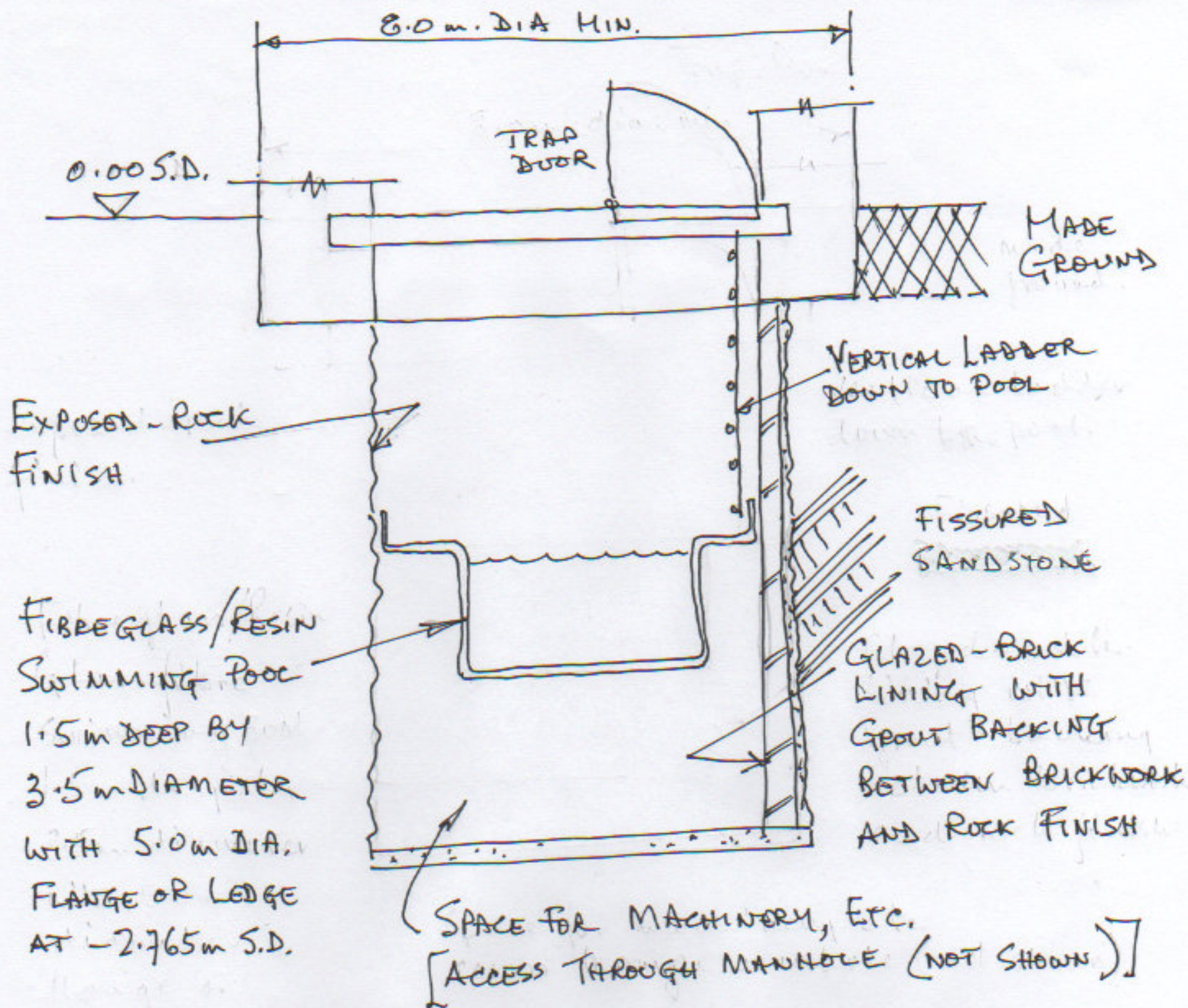

FIBREGLASS POOL STIFFENED BY SUPPLIER SO THAT IT CAN BE SUPPORTED ON 5.0m DIAMETER WHEEL-LIKE SUPPORT STRUCTURE EX 100 x 100 x 3.0mm SHS OR EQUAL

WEIGHT OF CONTENTS

$$= \frac{\pi D^2}{4} \times h \times 10 \frac{\text{KN}}{\text{m}^3}$$

$$= \frac{\pi \times 3.5 \times 3.5 \times 1.5 \times 10}{4}$$

$$= 145 \text{ KN OF WATER}$$

LOAD ON PERIMETER = $\frac{145}{2\pi D} = \frac{145}{2 \times \pi \times 3.5}$

$$= 4.6 \text{ KN/m run.}$$

FIG. 3

The exploration uncovers a host of features that need to be resolved in the answer. The task is ^{partly} duplicated because two distinct and viable solutions are needed. Let us take the logical order of construction:

- o Access to the site - both into and away from the work. 1500 m along a narrow, winding lane is indicative of a mere farm track suitable only for farm tractors and trailers or something like a JCB or a tractor shovel.

The question does not specifically exclude large vehicles [like a ready mix truck] or articulated vehicles. However, the Candidate is expected to comply with the "spirit" of the situation: one cannot ^{expect to} bring ^{large} prefabricated units and erect them using a large crane! ["Transportation limitations" see Cobb "Design Data"]

In consequence the extensive use of reinforced concrete [either in situ or precast] or long steel or timber (glulam) members need to be restricted. Applying these constraints to the foundations the superstructure loads will be applied directly to the fissured sandstone.

- o The 8.0 m diameter area of the house will be cleared and 500 mm of "Made Ground" excavated - a JCB or similar would be used.

The 5.0 m diameter of the basement can be cut to an exposed-rock finish. The depth will be 2.765 + 2.765 to accommodate the swimming pool and all the pumps, etc. needed.

- o The rock spoil from the cellar may be broken into small pieces and spread to improve the road surface [thus saving the cost of taking it to tip].
- o The excavation of the fissured sandstone can be done with a "Pecker" ^[Hydraulic rock breaker] on a JCB which will break the rock into small lumps; these in turn would be dug out using the JCB bucket and some manual work. A dumper would be used to cart the spoil away. ^{Used on} the road ^{this} would effectively be shaped and surfaced with water-bound macadam before the bulk of the building materials needs to be delivered.

If the inner surface of the cellar needs to be relatively even a procedure called "stitch drilling" could be used. In this procedure the sandstone would be drilled at close centres around the 5.0m diameter perimeter. This will ensure that the rock will break along the line of holes leaving a drilled corrugated surface with intermediate broken cusps. The rock drill and compressor will be able to reach the site along the farm track.

Blasting must be avoided because of the cliff and the nature of the fissured ^{sandstone} ~~limestone~~. The alternative is a non-explosive expansive mortar such as "DYNACEM". Holes are drilled into the sandstone. When the pattern of holes is ready the powdered "Dynacem" is mixed with water and poured into the holes. The subsequent expansion tears the sandstone apart.

Non-Explosive Demolition Agent DYNACEM



DYNACEM is a heavily swelling mortar for non-explosive demolition. It expands soundlessly, tears apart structural elements and separates reinforcing steel from concrete. You only need a hammer drill to use it:

1. Begin by drilling the holes:



2. Mix DYNACEM with water and pour into the holes:



3. DYNACEM expands, CRUSHES and TEARS APART boulders, rock and reinforced concrete:



DYNACEM IS SEVERAL TIMES QUICKER THAN HAMMERING!

Appropriate distribution of holes allows:

- crushing into large, or small pieces:

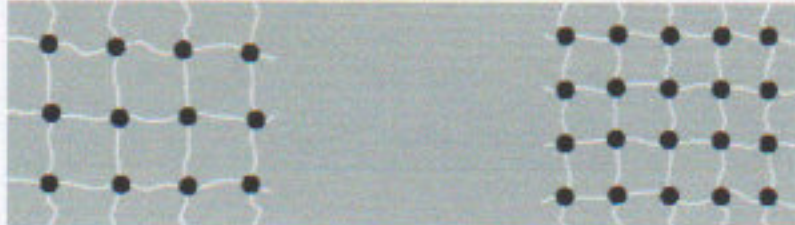

- dividing into sizes suitable for transport:

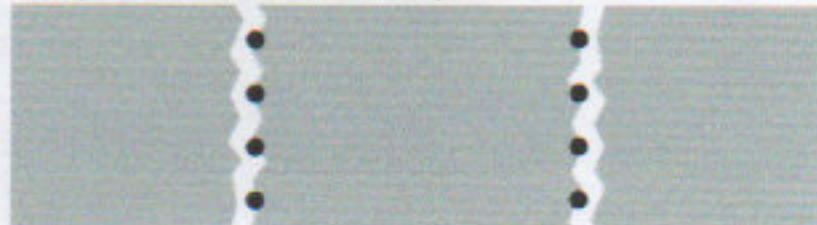

ADVANTAGES:

- accelerates demolition,
- no noise, vibrations, sparks and exhausts,
- no heavy machinery,
- less hammering and energy consumption,
- no flying debris, fire and toxic gases,
- controlled path/run and pattern of cracking,
- controlled demolition zones,
- "cutting" along designated lines,
- breaking into desired sizes,
- no precautions and qualifications for handling explosive materials are required.

APPLICATIONS:

- dividing beams, bases and foundations into pieces suitable for transport,
- demolition of structures, rock breaking,
- breakouts and openings in slabs and walls,
- tunneling, trenching and rock excavation,
- removal of rocky humps and boulders,
- exposing and releasing steel reinforcement from surrounding concrete,
- cutting concrete piles,
- quarrying stone blocks with minimal waste.

IDEAL SOLUTION

when heavy machines, noise, or vibrations are undesirable.

Non-explosive demolition agent DYNACEM will help when:

- deconstruction, concrete crushing, demolition, or hammering tools rental is your business,
- concrete removal, demolition, splitting and breaking rocks, concrete or stones is your favourite activity,
- you encountered an obstacle and need to hire a concrete breaker, hydraulic breaker, jackhammer, rock breaker or demolition shears,
- you're wondering how to break concrete, or a rock, how to remove a foundation, or demolish a wall.

Demand for non-explosive and vibrationless demolition has experienced an exponential growth in the past years. An increasing amount of construction, or demolition jobs is performed in densely populated areas and even inside existing structures. Work needs to be carried out without damaging the nearby structures. Non-explosive demolition agent guarantees minimal risk in such situations.

Since 1989, we've been repairing and modernizing reinforced concrete structures. We are a member of ICRI - International Concrete Repair Institute. We are convinced that DYNACEM is a great method of chemical demolition that doesn't cause damage to the surroundings. Our

(FOLLOWS PAGE 4)

The walls of the cellar could be lined with glazed brickwork. The rock face would need to be cut further back and the brick skin built inside with the rough gap between the brick and rock filled with mortar.

- The circular swimming pool would be pre-formed in fibreglass and brought to site. It would be supported at the right level by a wheel-like steel structure fabricated in three equal segments that would be bolted together on site. The floor would be laid to level [a cement screed] with the steelwork placed on top.

Plumbing and drainage would be attached in situ using electrically driven pumps, etc.

- The house walls would be built directly on top of the exposed sandstone. Any weathered sandstone [none reported] would be removed. The cavity walls would be combined into a single common footing using engineering brick and cement mortar.

Above ground level the cavity-wall form would be developed using a d.p.c., timber-joist-and-board-flooring and insulation.

- Complications begin to appear in the Superstructure:

1. The manner of supporting the floors,
2. How to provide a door and windows,
3. How to provide the balcony at each level,
4. How to insulate and weatherproof the building
5. How to include a staircase.

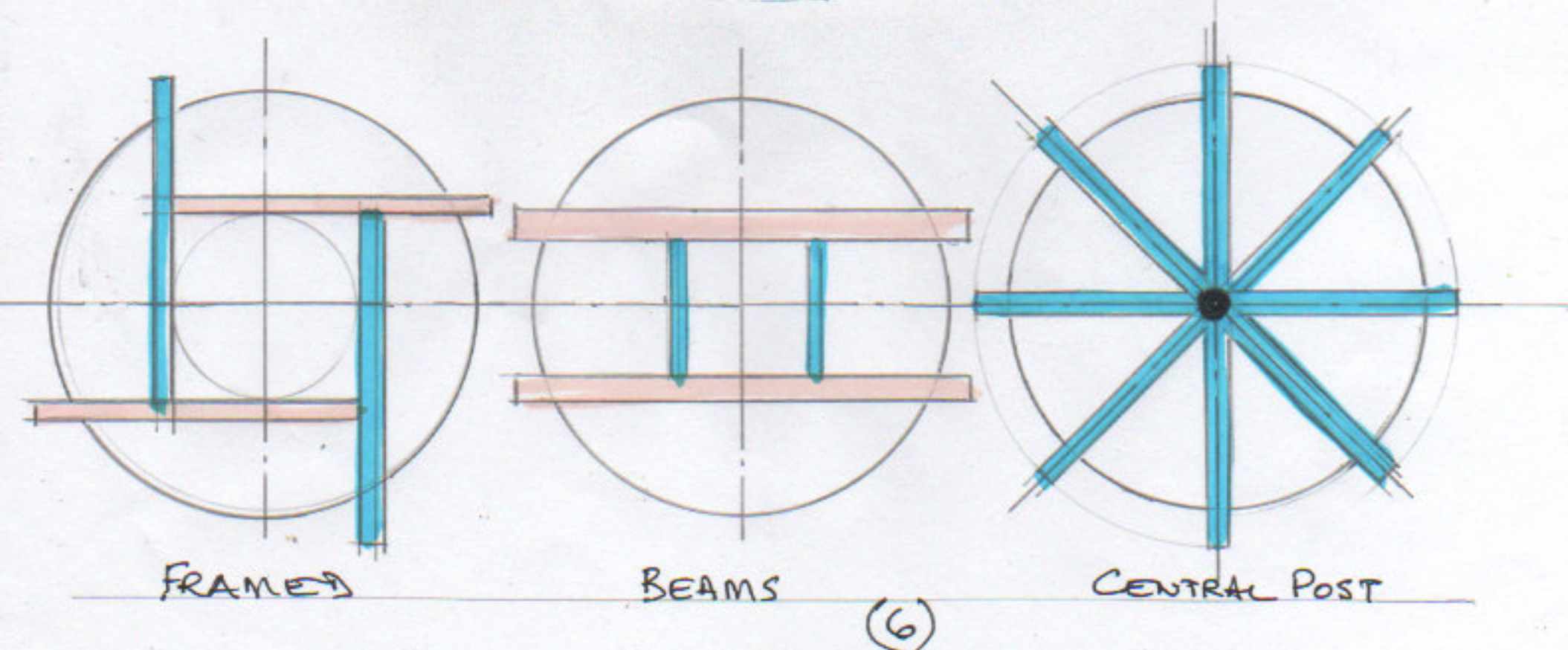
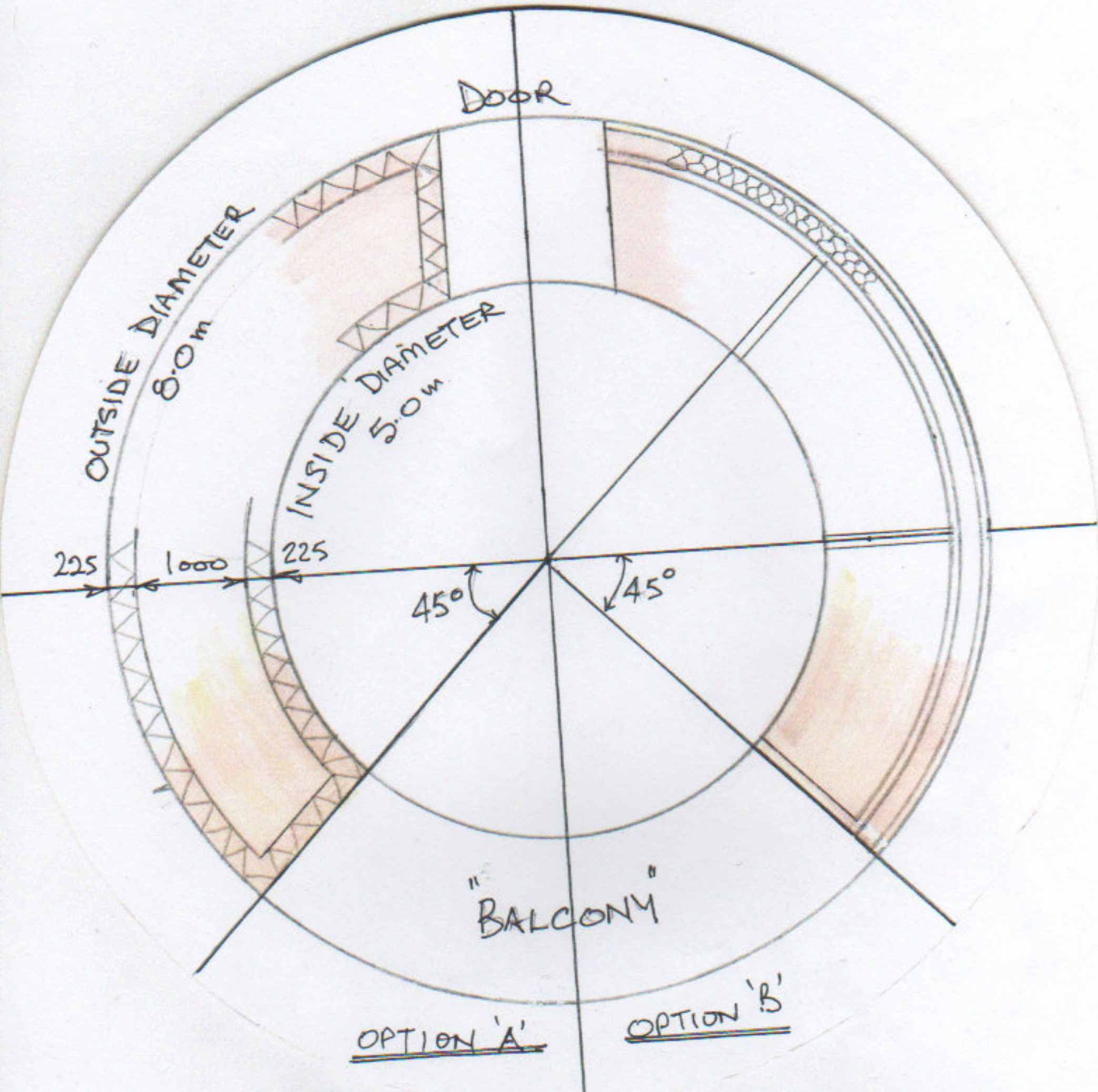

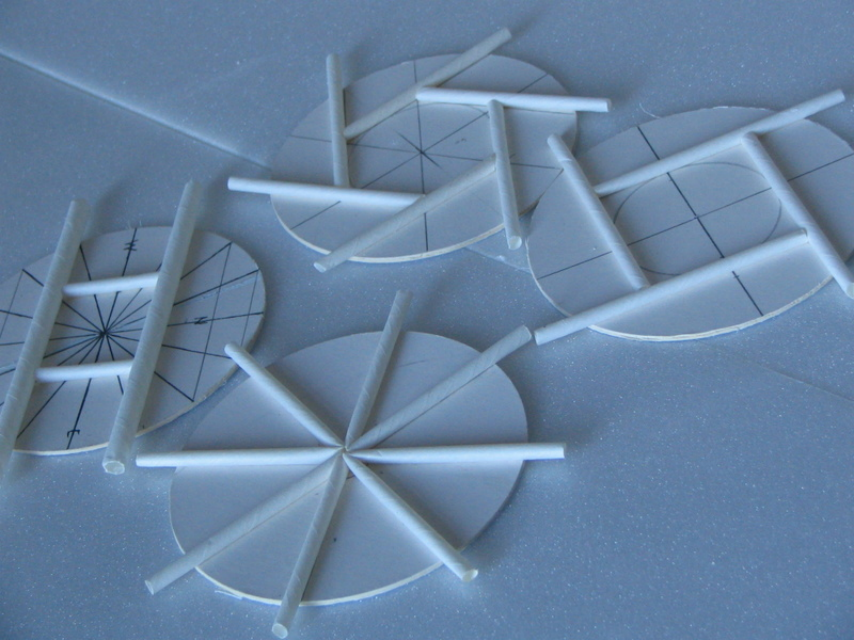

VISUALISATION OF CONCEPTS:

ARE YOU PREPARED FOR CIRCULAR BUILDINGS?

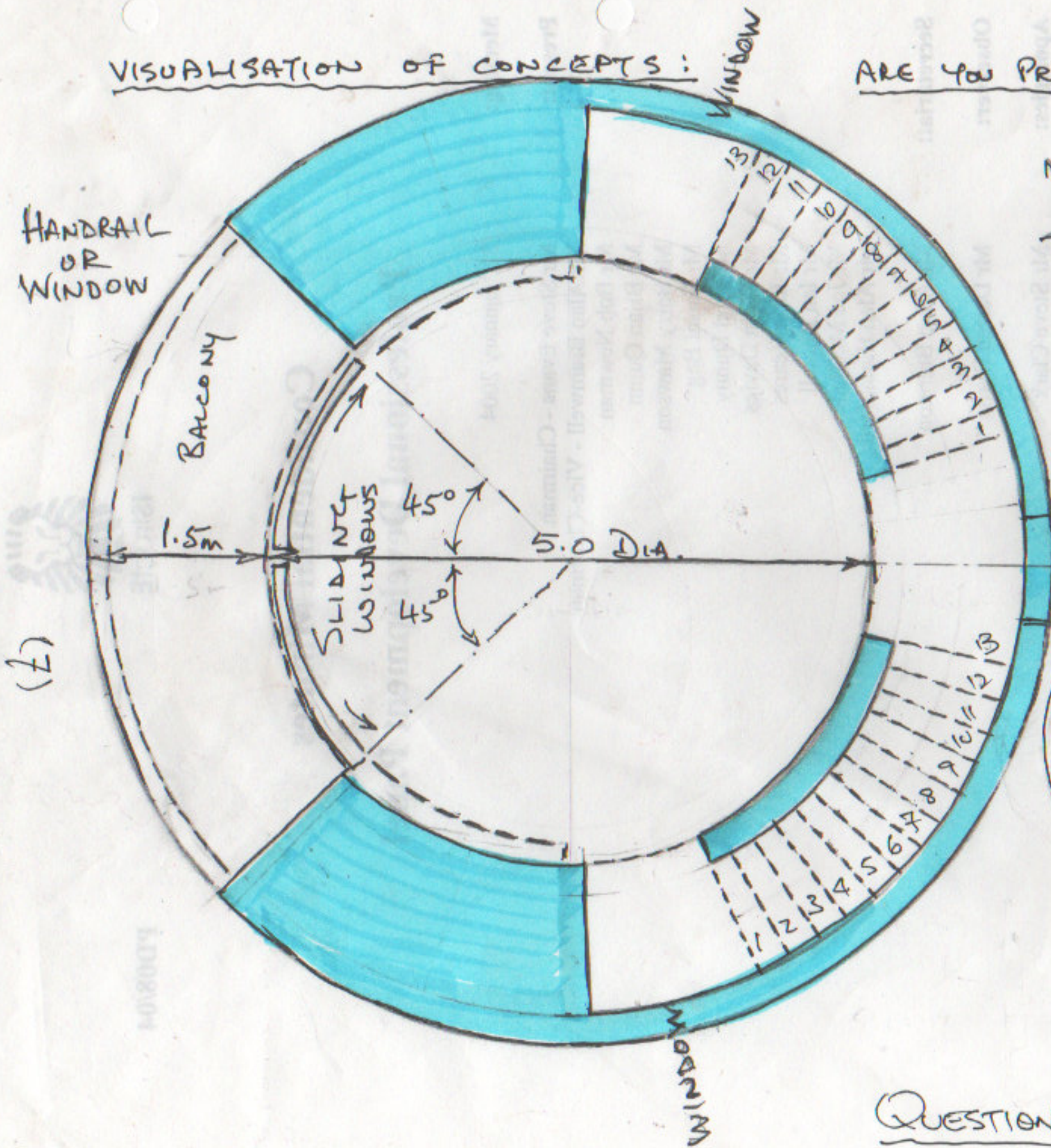

NO VALUES ARE GIVEN AT THE VARIOUS LEVELS \therefore MIN CLEAR HEIGHT ASSUMED TO BE 2.6m

LET $L/d = 30$ SIMPLY SUPPORTED 2-WAY $5 \text{ kN/m}^2 > 1.5$

TRY $\frac{5000}{30} = 167$.

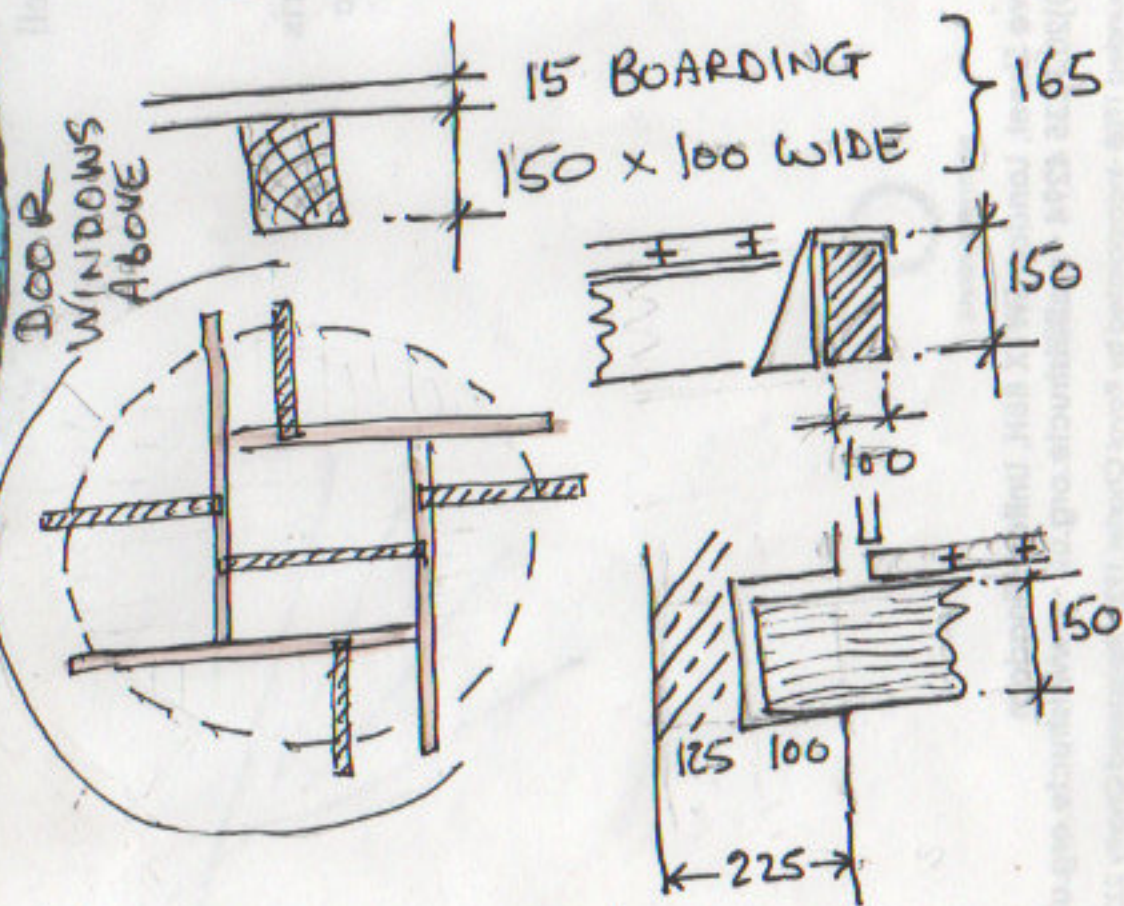

QUESTION 5-2014 CLIFF-TOP HOUSE

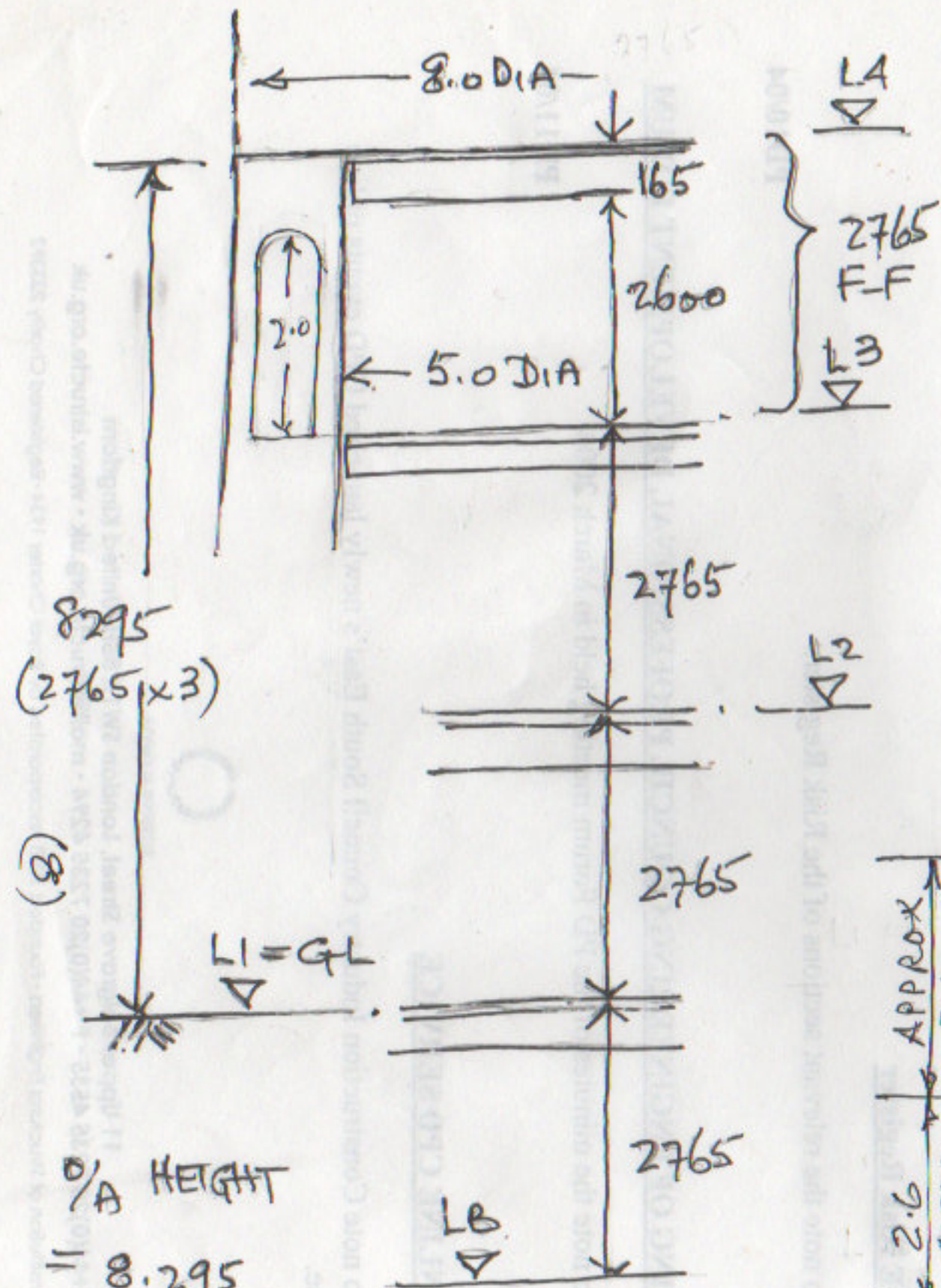

% HEIGHT

= 8.295
2.6
3.1

13.995

SAY 14.0 m.

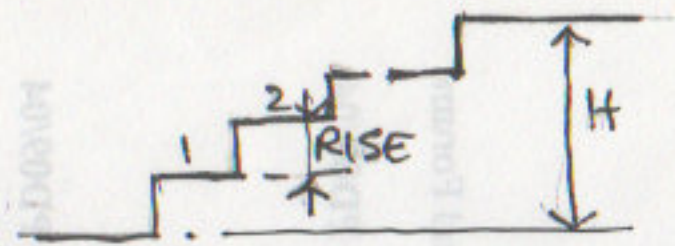

$$\frac{H}{\text{RISE}} = \text{WHOLE NUMBER OF RISERS.}$$

TRY RISE = 170 $\therefore \frac{2765}{170} = 16.26$

$\frac{2765}{16} = 172.81$

MAX RISE = 210

$\frac{2765}{210} = 13.17$

$\frac{2765}{13} = 212.7$

NOT MORE THAN 16 RISERS

MIN GOING (PRIVATE STAIR) = 220

MIN OVERLAP = 16 mm.

VERTICAL CLEAR HEIGHT = 2000

MIN WIDTH BETWEEN HANDRAILS = 1000

GOINGS = NO RISERS - 1 $\therefore 13 - 1 = 12$

LENGTH = $12 \times 220 = 2640$

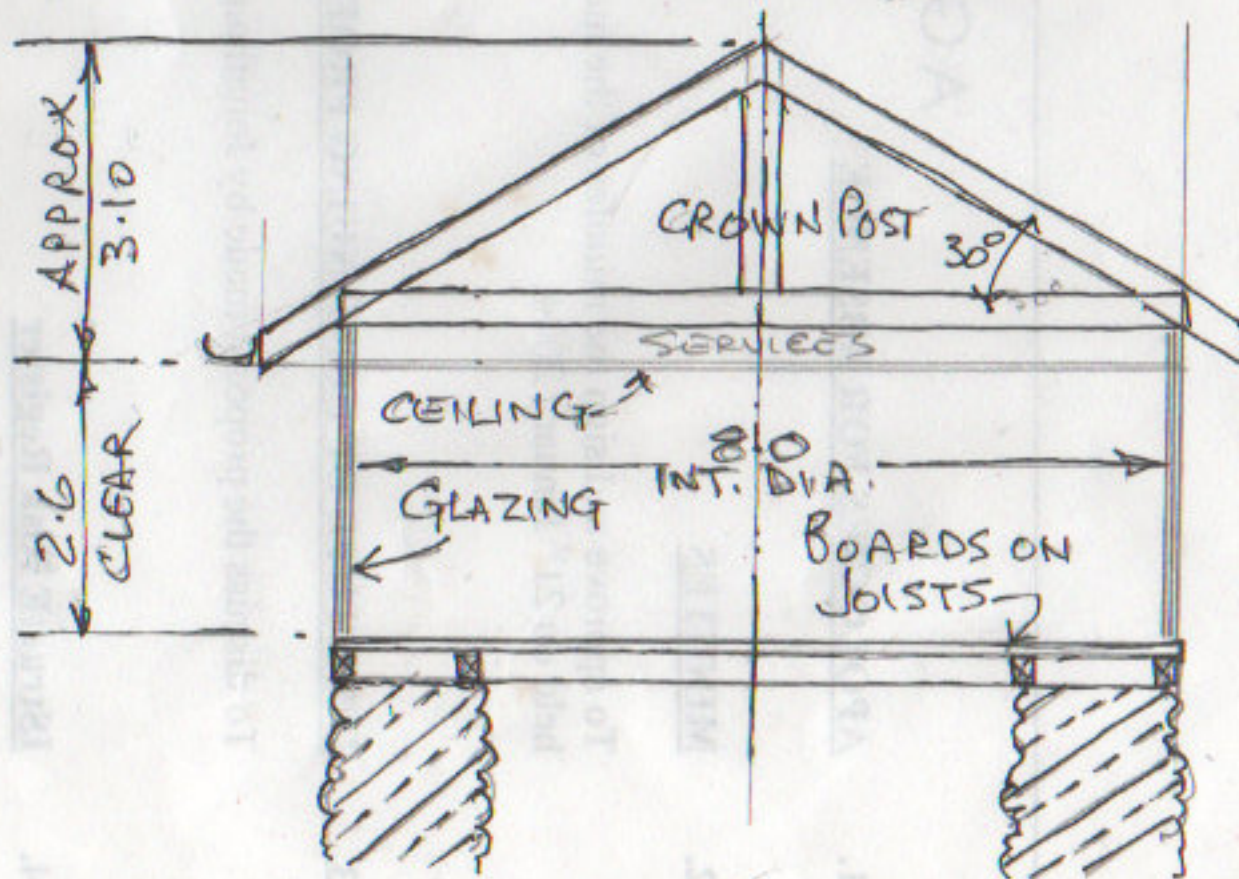
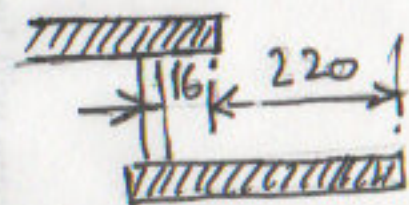

$$\frac{L}{d} = \frac{8000}{30} = 267$$

BOARDS 15
282

USE 220 x 63 JOIST

AT 400 CRS

DL 0.50 TO 1.25

SPAN 4.51

ARCHITECTS POCKET BOOK

- o There are to be three 5.0m diameter floors. Because of the "domestic" use of this building it has been decided to use timber joists and boarding. Although the question permits internal columns below level 4 - e.g. a central column - this will intrude upon the living space. Consequently the "central post" arrangement of joists has been avoided. [See pages 6 and 7].

The "framed" arrangement uses slightly shorter joists ^{but} the need for a tusk-tennon joint between the joists or a joist-hanger complicates this form of support.

Hence the basic pair of beams [with stretchers] has been chosen. The boarding will be laid across the beams and supported by a ring corbel at the wall. Perhaps a circular "wall plate" would be used too.

The underside of the t-and-g boarding will be exposed to view (i.e. no ceiling)

This construction provides the shallowest floor depth. The timber lengths can be brought up the Lane and man-handled into place.

- o The floor at Level 4 is dealt with elsewhere. No internal columns above level 4 are allowed. Consequently the roof cannot be supported on a central post; there is no need for a central support below this level.

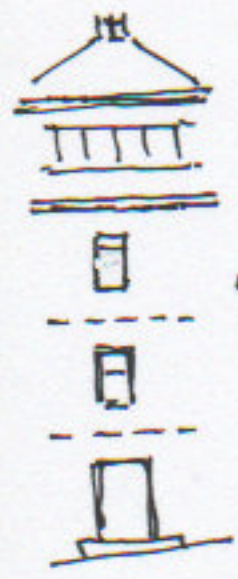

o The basic viability requires at least one front door. This has been provided on the handward side at ground level (Site Datum 0.00). Because of the 1500 thickness of the structure it should be possible to create a storm porch.

o It is proposed to have the floor-to-floor stairways within the wall thickness above the doorway. The stairway will be lit by windows arranged vertically above the door.

With the Floor-to-Floor height restricted to 2.765m it is estimated that 13 risers are needed. The rise equals 212.7mm, slightly over the maximum of 210mm. If this is not permitted by Building Control then 14 risers will be provided [$< 16 \text{ max}$] with a rise height of $\frac{2765}{14} = 197.5 \text{ mm}$.

The number of 'goings' = $[N^{\circ} \text{ risers} - 1] = 14 - 1 = 13$.

The length of each 'going' = 220

Therefore the length of the stairs = $13 \times 220 = \underline{2860 \text{ m}}$

There needs to be a 'landing' space at the head and foot of each flight at least as wide as the stairway itself, i.e. 1000mm.

o The balconies on Levels 2 and 3 look seaward over the cliff and are shown to be 1500 measured from the 5.0m diameter floor area perimeter. This dimension is the same as the 1500mm wall thickness. It is entirely credible that both balconies, and potentially a 'french window' at Level 1, will be enclosed with triple glazing that also provides a balustrade. In this way the 'balcony' provides additional safe floor area.

When I discussed the question with my wife she agreed that the Cliff-top House would be a nice 'querky' bachelor pad but was quite alarmed when she learned that twin babies were to be introduced! What with the cliff edge to the garden, the remote location, pool, balconies and narrow stairs she felt glad that we had no similar plans in mind. However, the Structural Engineer has to provide what the Client requires!

- The thick walls can be insulated and the windows can be tripple glazed. The outside of the masonry walls can be rendered or painted with cementitious paint - like a lighthouse. However, because of the cliff-top location the wind and driving rain will require extra protection as compared to the common house.
- The circumference of the walls is interrupted by the door and windows above, and by the balconies. Consequently there will be incorporated a ring beam at each floor level to prevent the walls separating. Each ring beam will comprise a section 565mm deep x 1500mm wide joined onto a precast concrete "balcony slab". This slab will cantilever outwards from a beam strip spanning over the balcony openings and bearing 300mm onto the walls beneath. The balcony slabs may be cast off-site if it can be delivered safely.

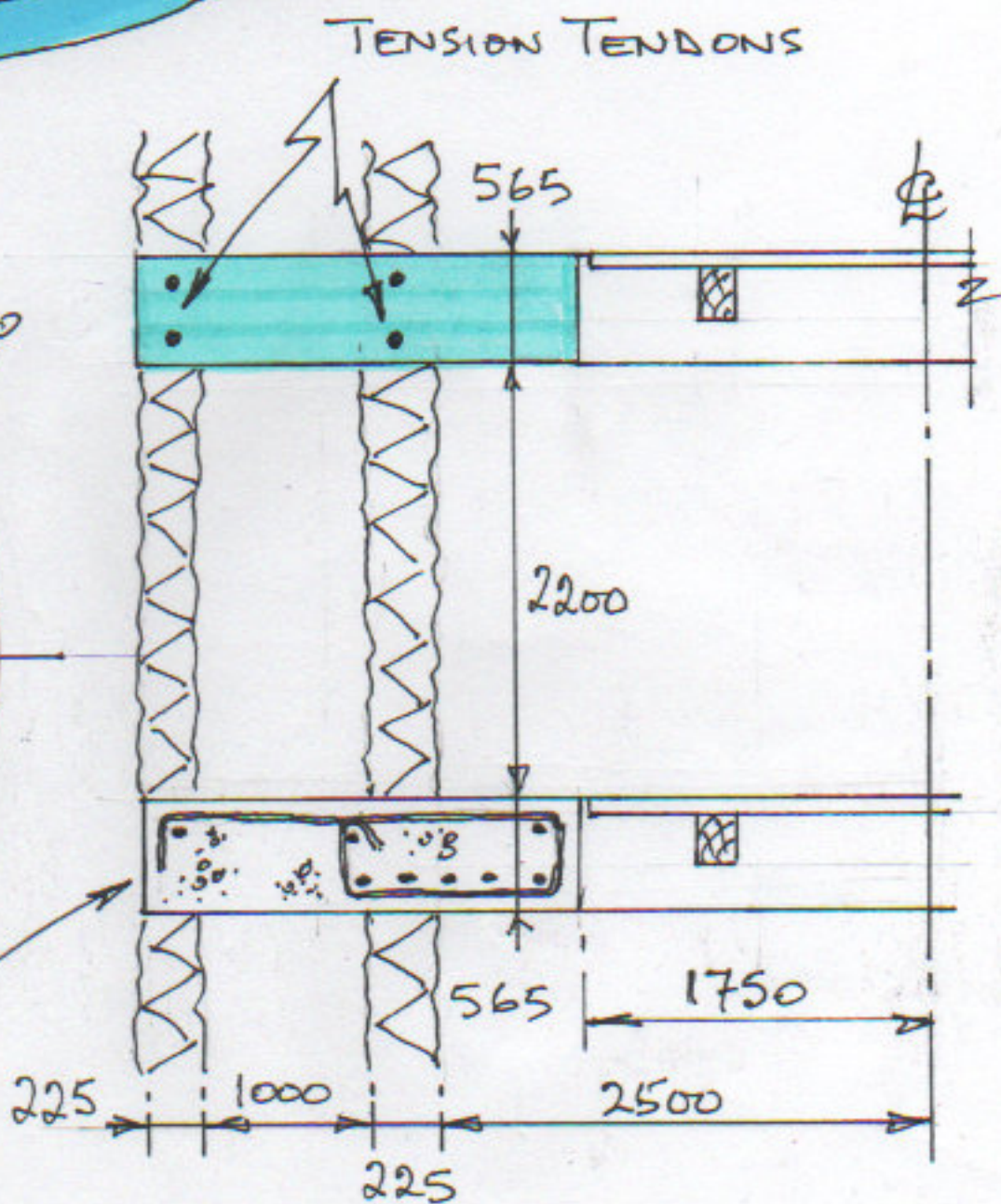
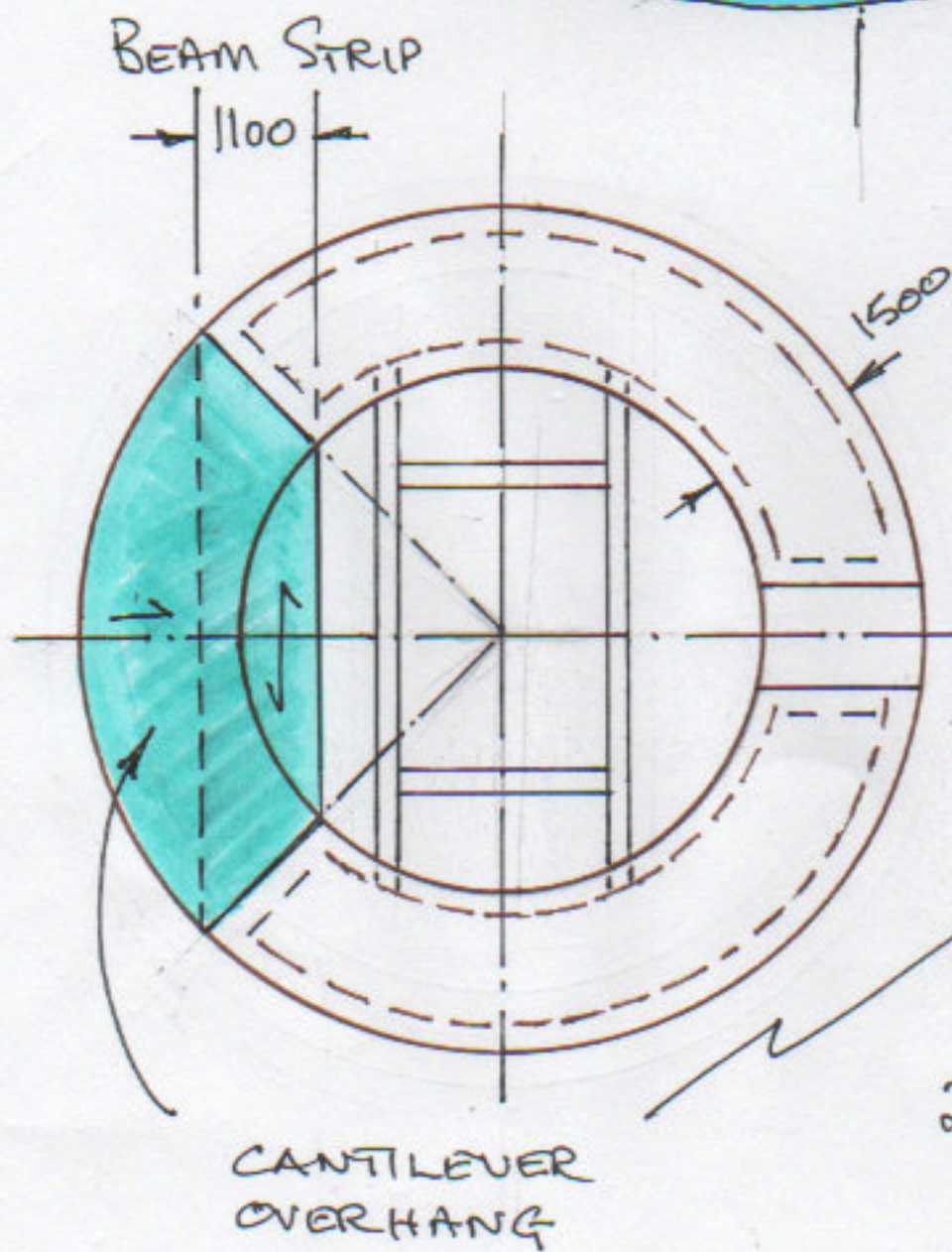
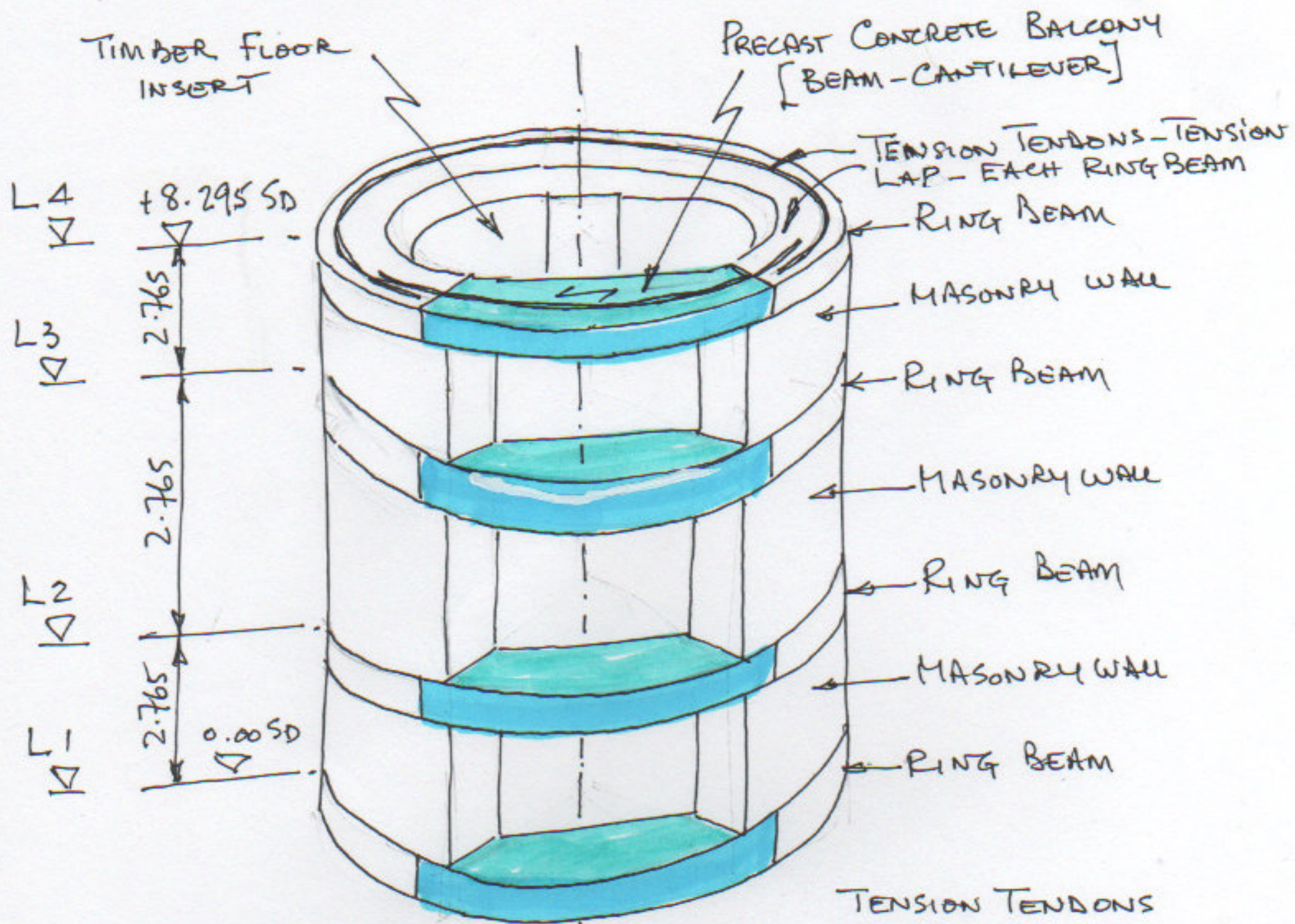

- o The final level of the house, the Family Room, is at the top of the staircase; the perimeter walls are windows and the roof is immediately above. No internal columns are allowed [Client's Requirement No. 4]. The floor diameter is 8.0m and projects over the tower below.
- o The "Apron Ring" diverts the wind from the windows around the Family Room and provides anchorage for the radial ties. The radial ties stabilize the six posts and the uplift from the wind over the roof. The rafters are supported by the posts and are "framed" around the apex of the roof. The Apron Ring will be cast insitu and reinforced with coated or galvanised rebar. A hardwood deck will be laid over the concrete.
- o The volume of concrete is approximately

$$10\text{m diameter} \times 565\text{mm thk} = \frac{\pi \times 10 \times 10}{4} \times 0.6 = 48\text{m}^3$$

By the time this operation needs to be done the road will have been made passable by lorries. Ready mix can be delivered to the house and pumped up into place.
- o The "Ring Beam" would ideally be in one piece, but this would be difficult to deliver and handle. Six lengths joined at each post and "fitched" with timber top and bottom will stiffen the tension-carrying plate and prevent it from deflecting above the windows.

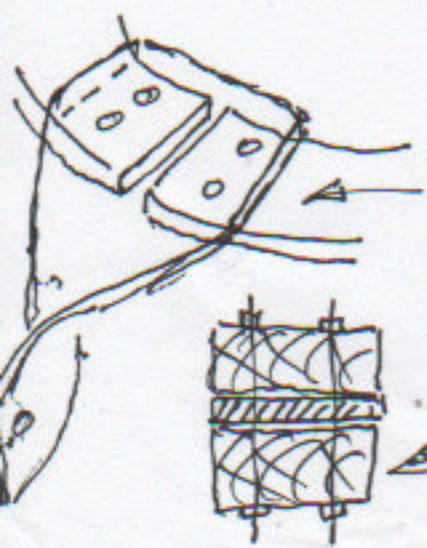

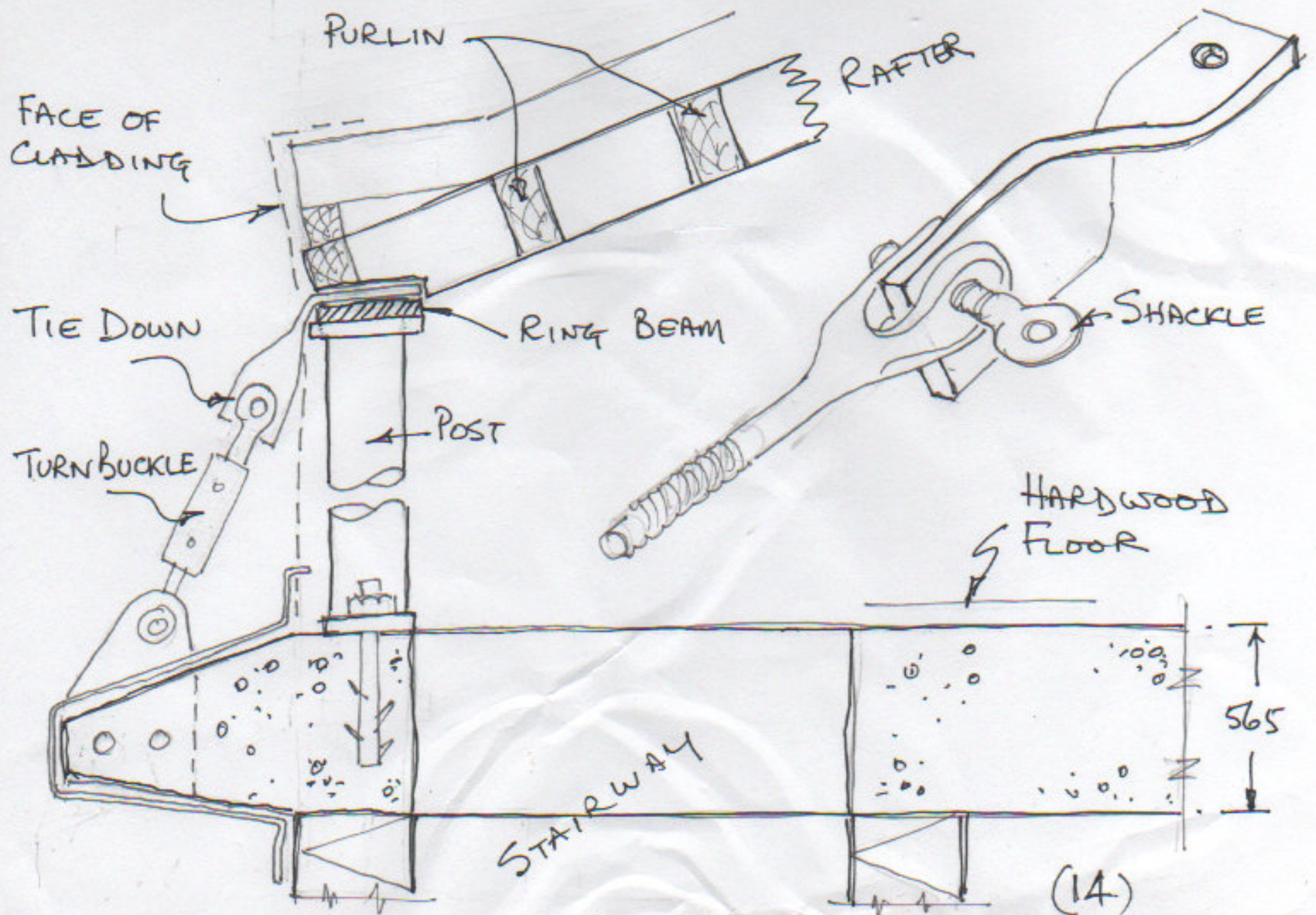
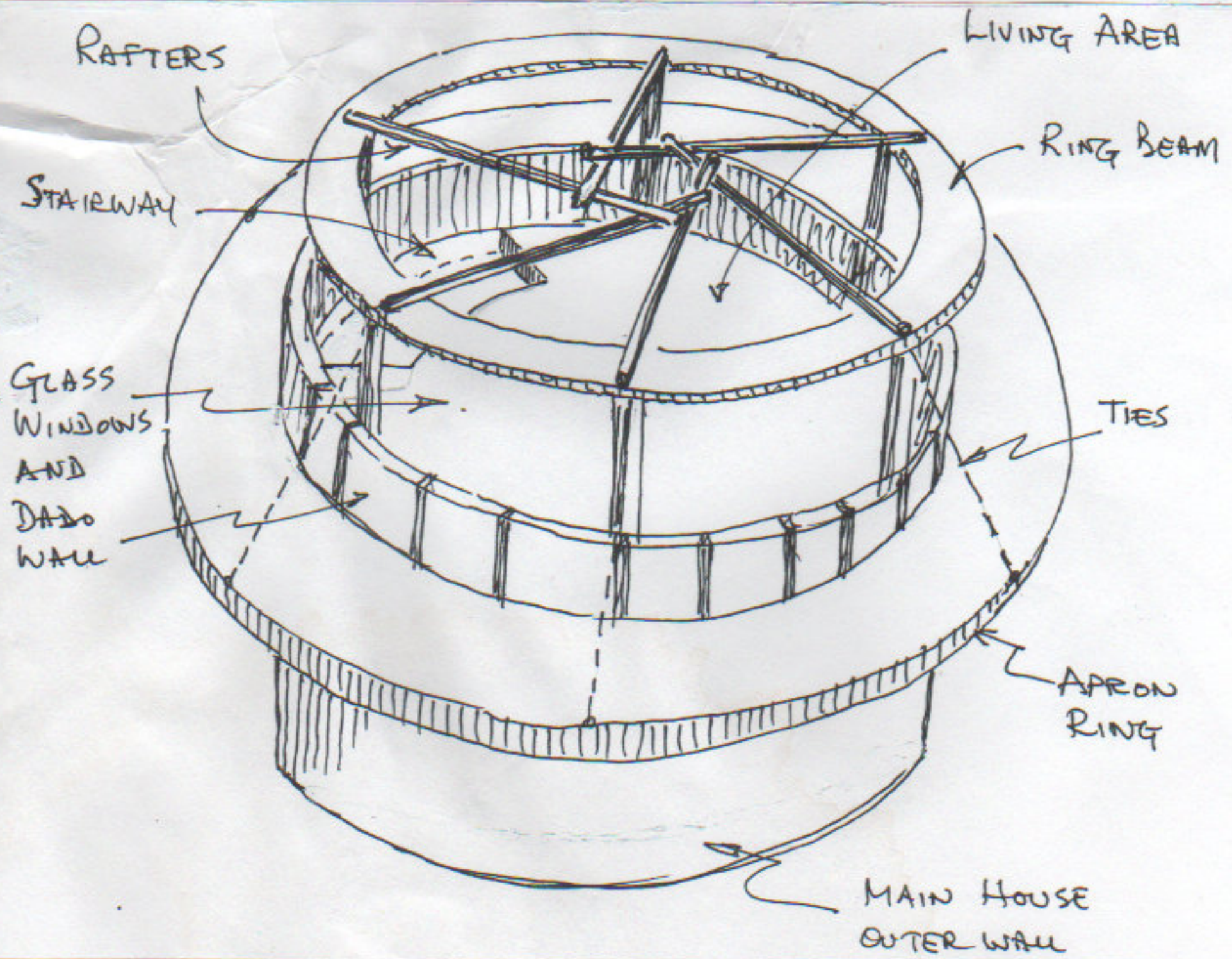

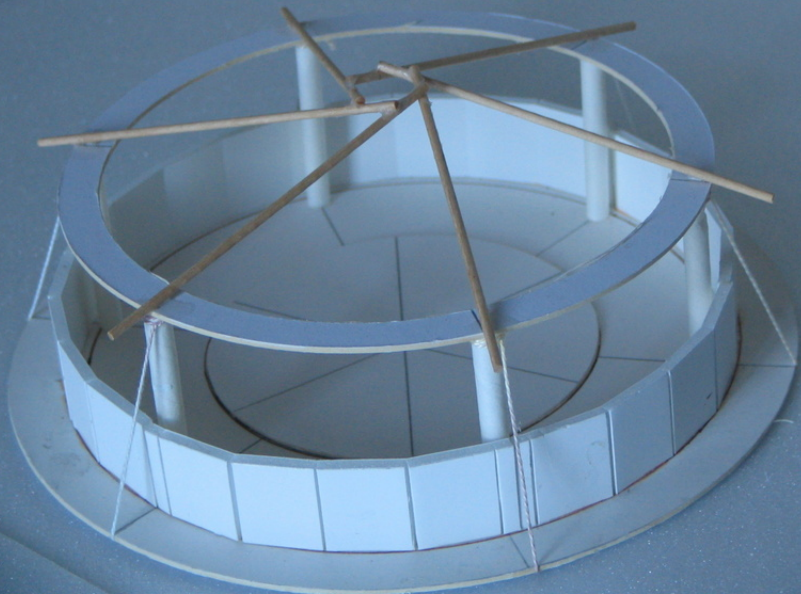

- o The drawings were done on A3-size pages and have been reduced. There are two General Arrangement type drawings showing Option 1 with the cavity walls, and Option 2 with the steel frames. The third page shows some Details. It is important that each part of the drawing or detail is finished. Don't go on over the whole page with half-finished drawings because these cannot be marked!

The marks - 20 for Section 2d - are divided approximately 10:10 between the General Arrangement and the Details. The Examiner is allowed to use his/her judgement concerning "Content", "Drawing" and "Lettering". What is wanted is a clear drawing that can be issued from the office without embarrassment, and that shows useful details of the proposed project. General notes will state what materials are to be used. Long irrelevant notes, sometimes copied from working drawings are often not appropriate. Generalised weights of reinforcement often do not apply.

- o Option 2 comprises horizontal and vertical frames clad with vertical insulated panels. The vertical frames are bolted down into the sandstone using a "levelling" frame into which the "Stanchion Blade" is fitted. This arrangement allows the base to be set and followed at a later stage by the stanchion, floor frames and cladding.

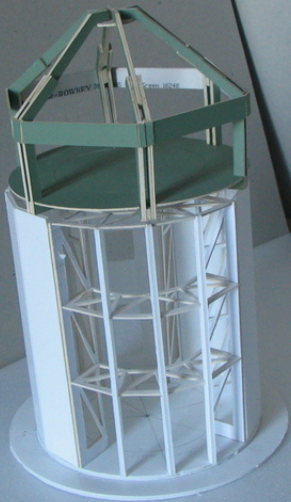

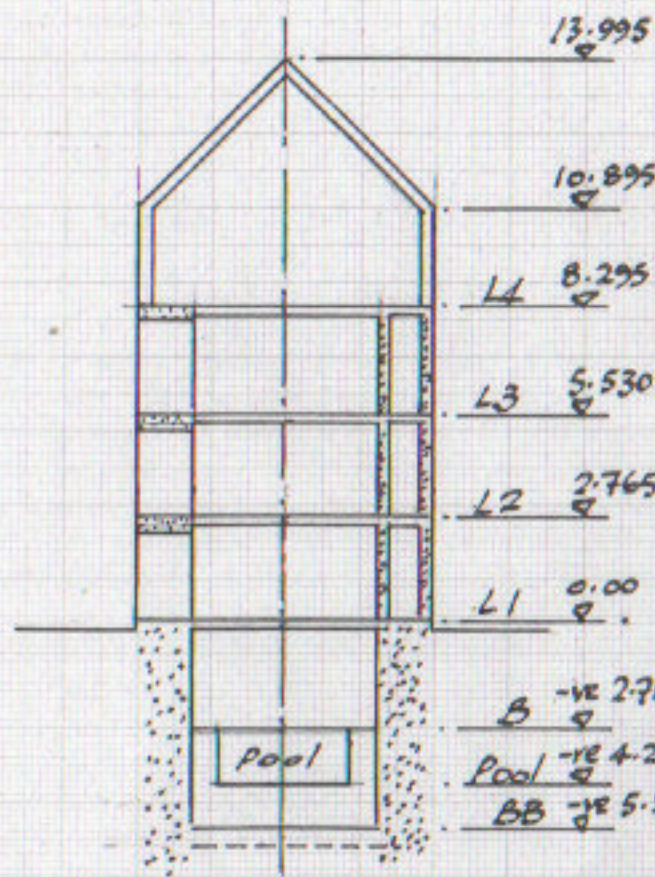

Roof and roof frames
see detail

Typical floor 5.0m dia.
16thk boards on
150 x 100 deep joists.
No ceiling.

Twin masonry walls
each 225 thk with
stair space 1.0m
wide between

Hollow cylinder of
natural rock ~
~ fissured sandstone ~
injection grouted to
consolidate and form
in-situ foundation.

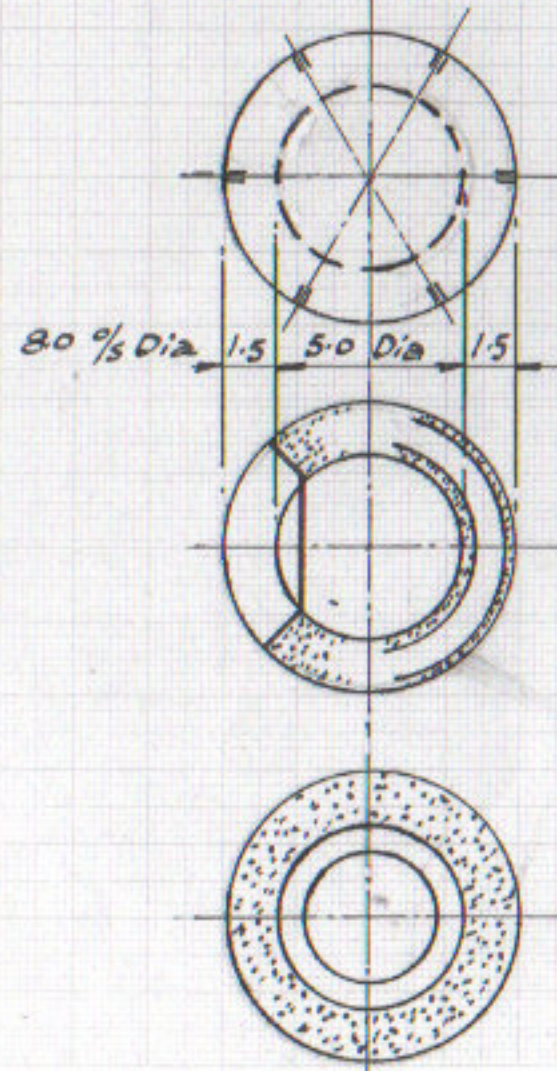

"Outlook Area" ~ low dado wall
with triple glazing. Roof rafters
double round to form radial
floor joists.

"General Floors" ~ Triple
glazed enclosed balcony.
Precast, pre-stressed concrete
balcony slabs - see detail

"Pool Area" ~ reinforced
plastic pre-formed pool bowl
in RHS support frame in
centre of plant area for
pool ~ all within grouted
foundation ring ~ see detail.

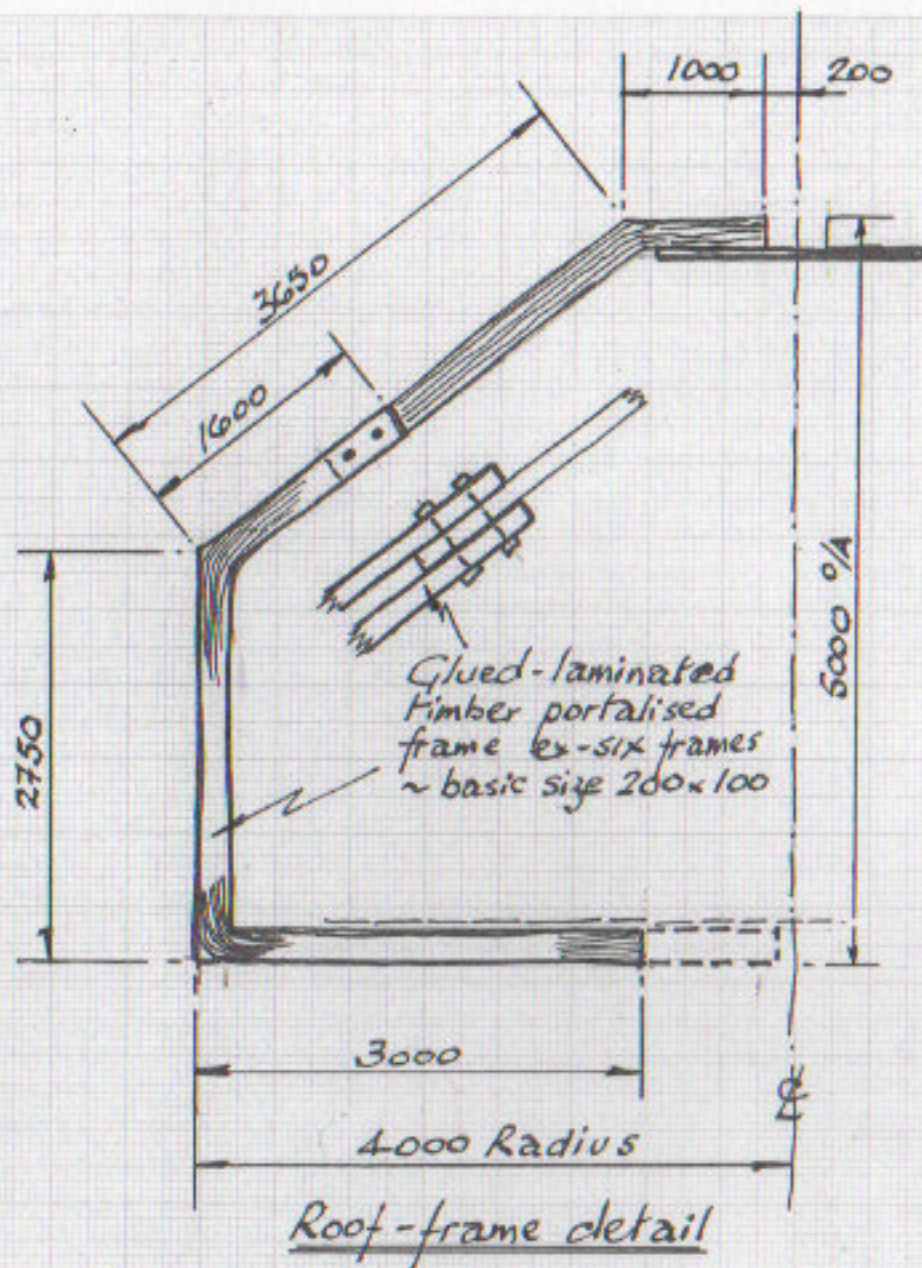

Roof-frame detail

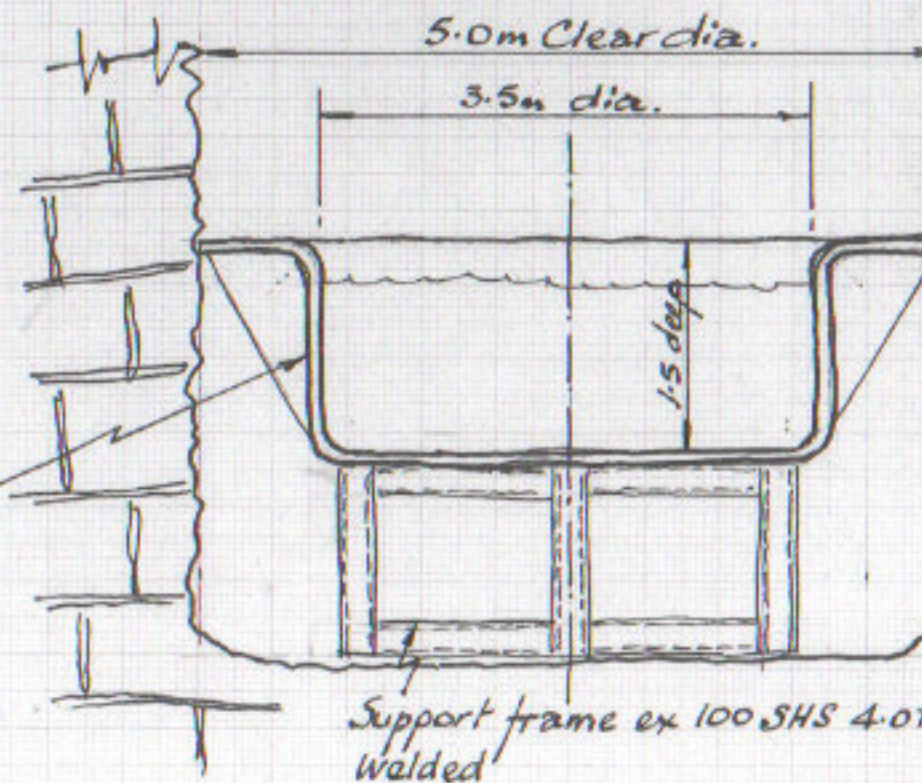

Support frame ex 100 SHS 4.0thk
welded

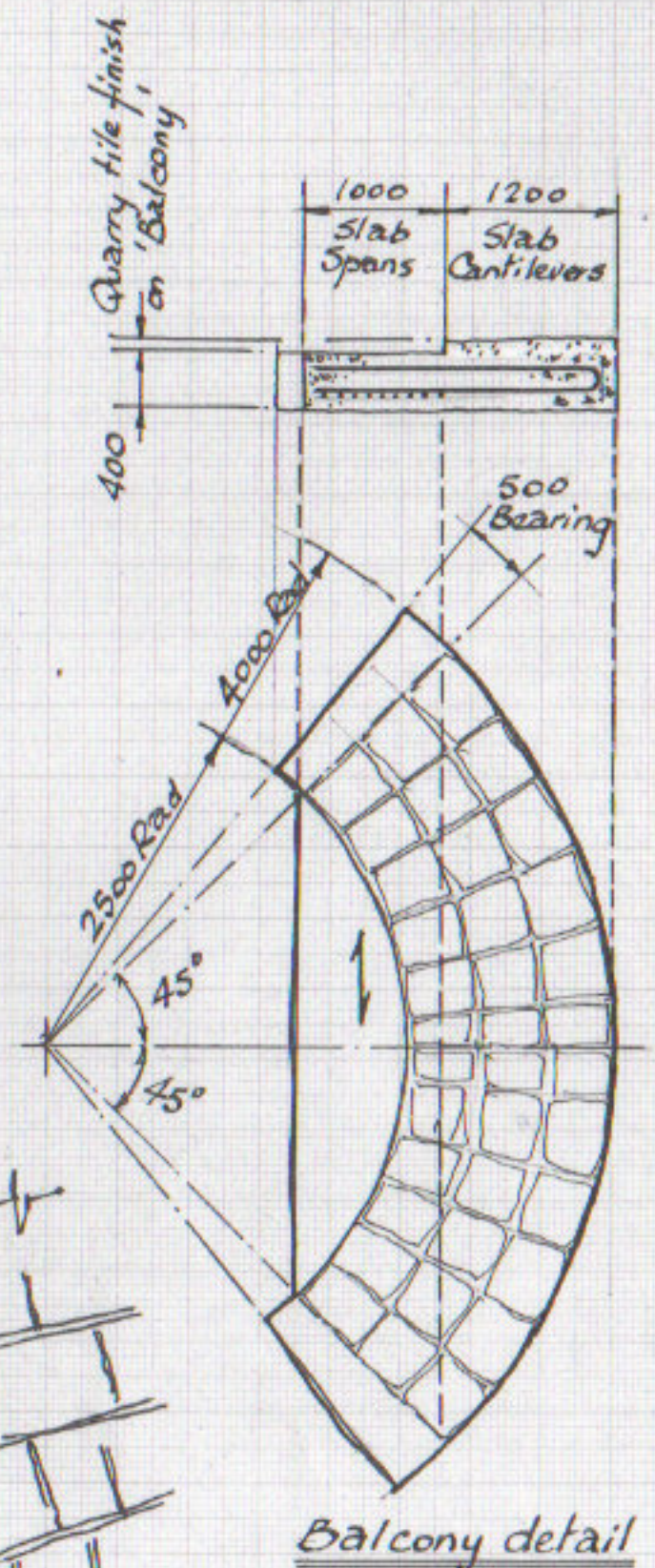

Balcony detail

Pool-area detail

Q5-2014 Cliff-Top
House (16)

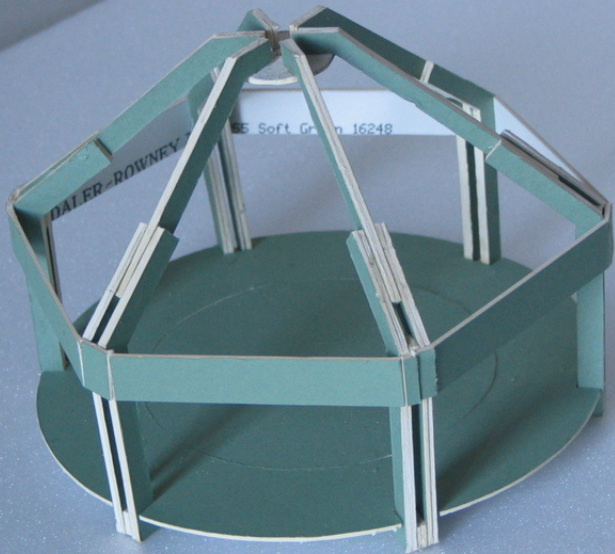

DALE R. ROWNEY

55 Soft Green 16248

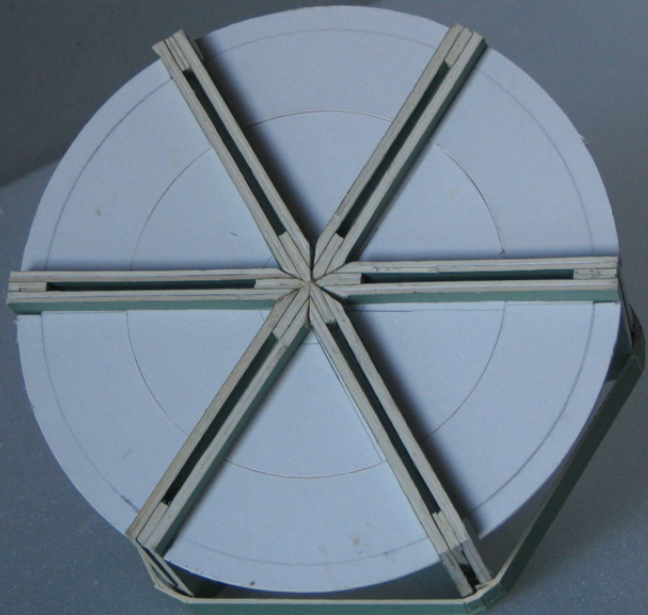

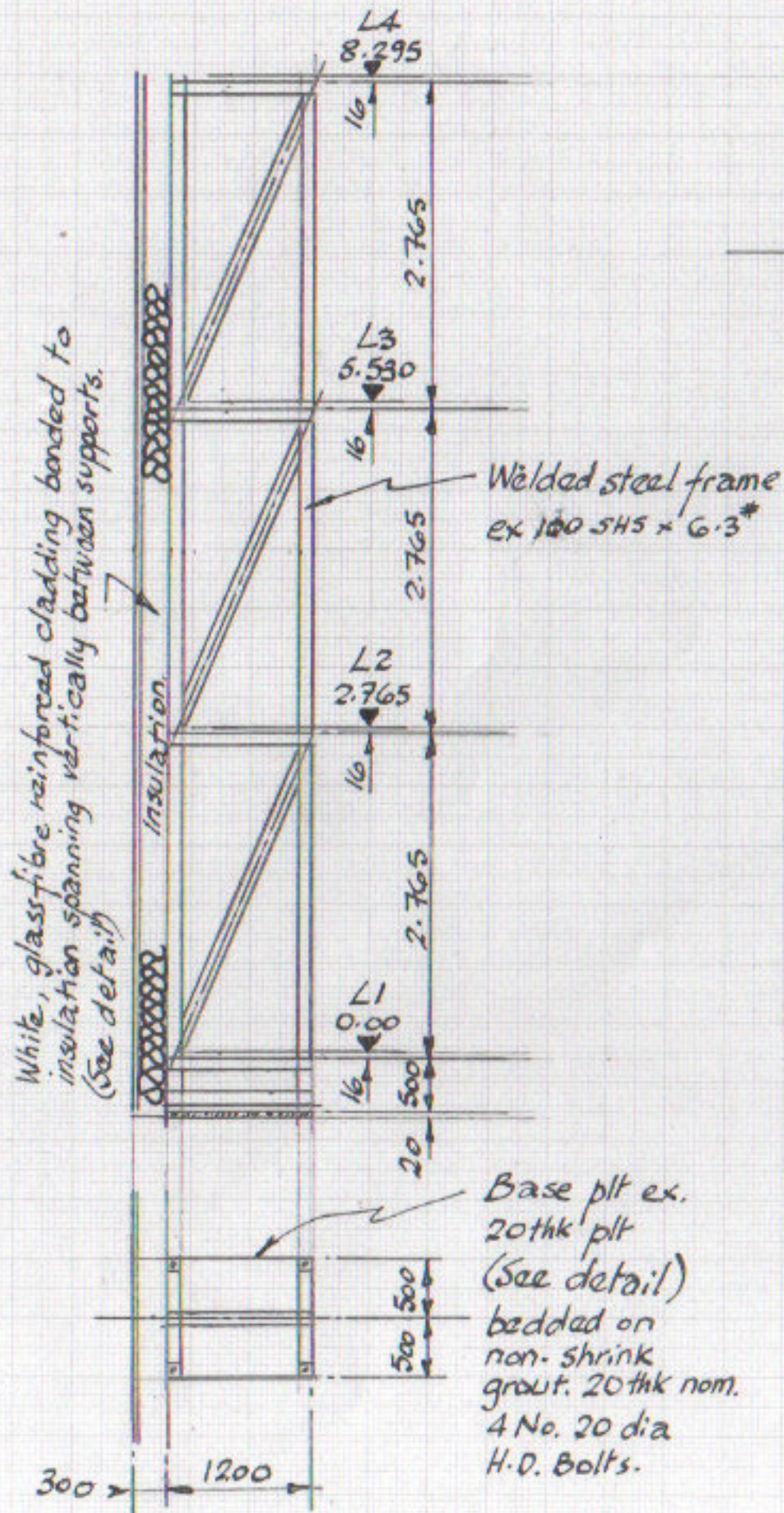

ELEVATION OF STEEL FRAME

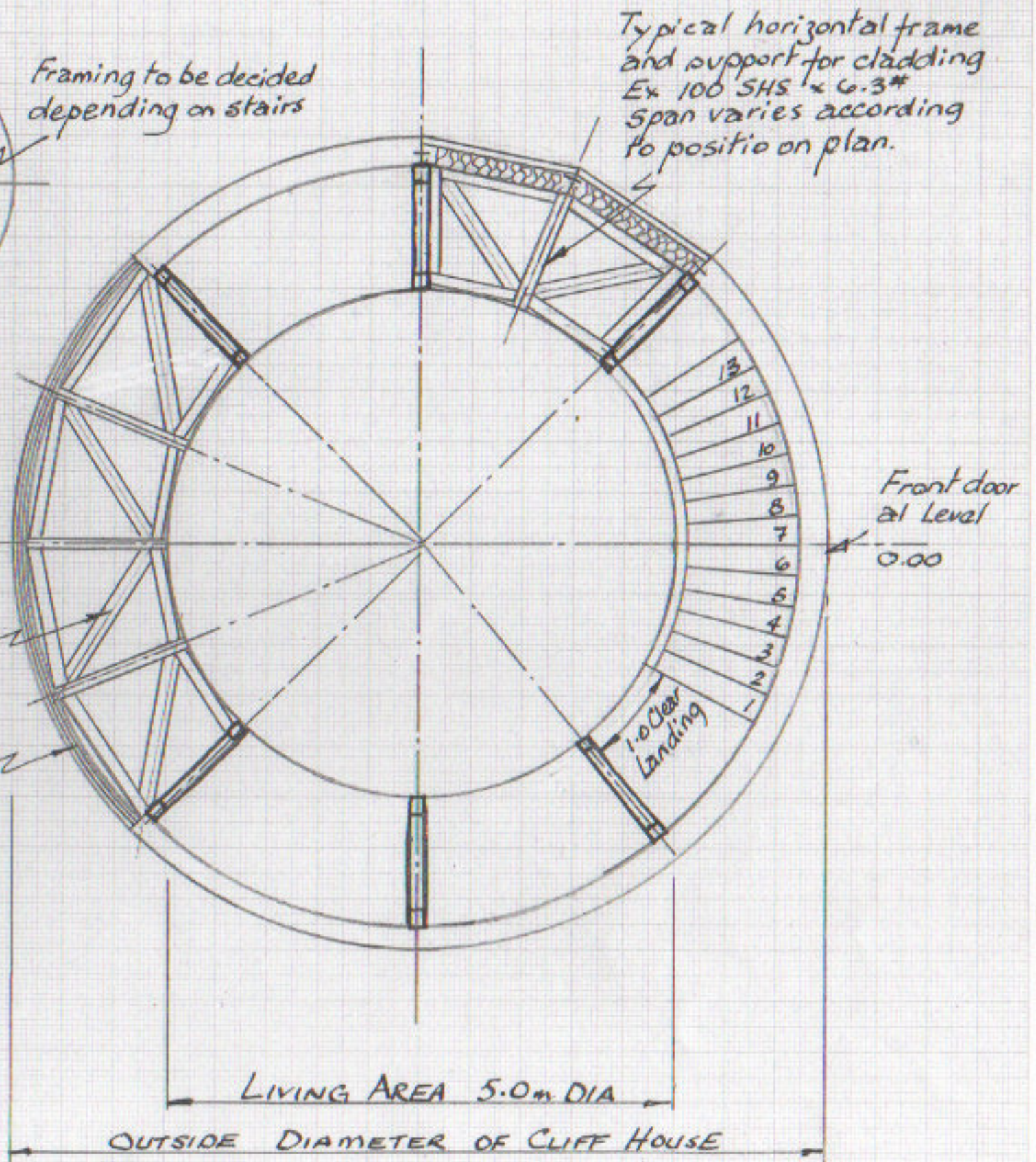
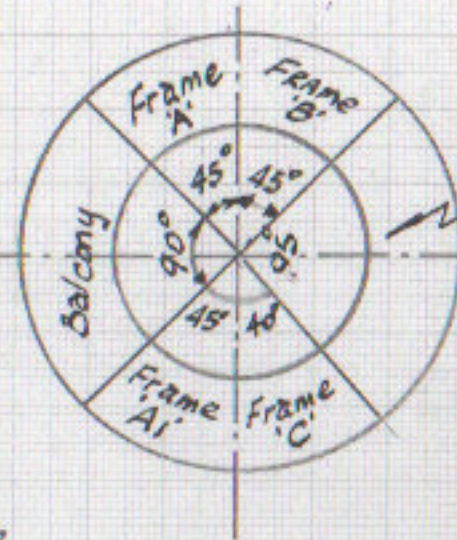

PLAN AND KEY PLAN SHOWING LOCATION OF HORIZONTAL AND VERTICAL FRAMES

Q5-2014 Cliff-Top House (17)

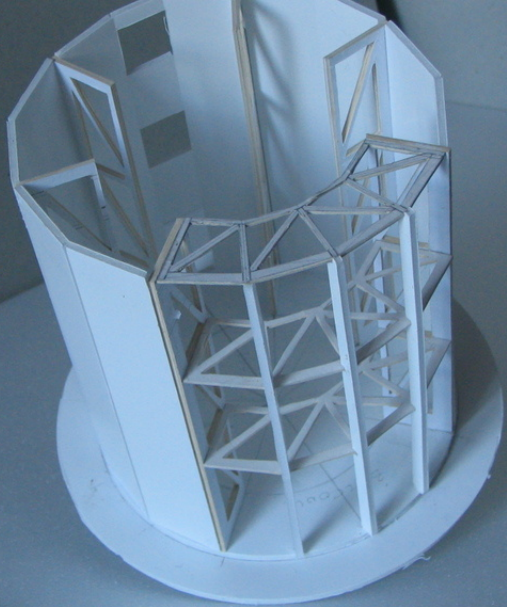

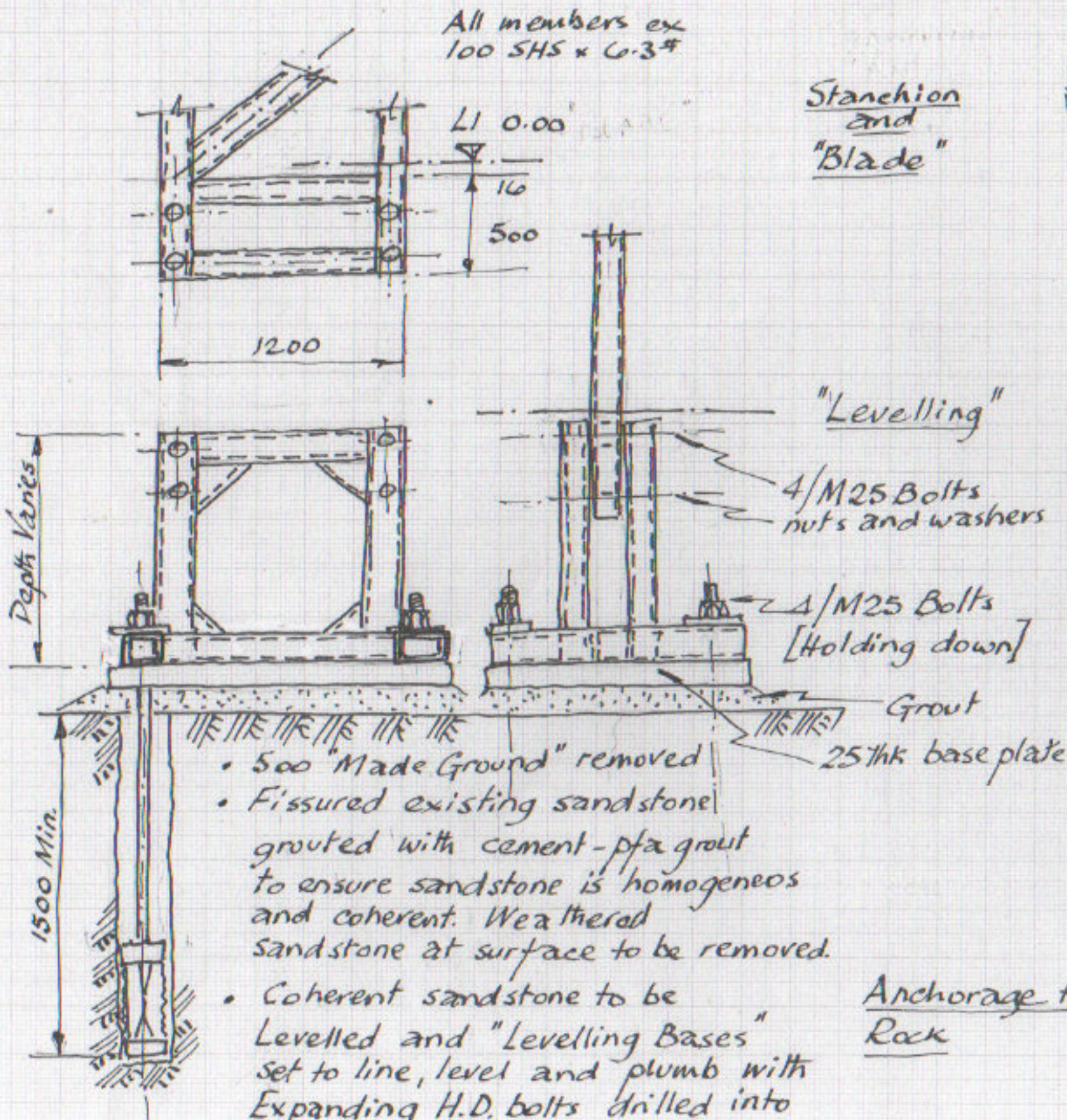

Stanchion and "Blade"

"Levelling"

4/M25 Bolts
nuts and washers

4/M25 Bolts
[Holding down]

GROUT

25thk base plate

Anchorage to Rock

- 500 "Made Ground" removed
- Fissured existing sandstone grouted with cement-pfa grout to ensure sandstone is homogeneous and coherent. Weathered sandstone at surface to be removed.
- Coherent sandstone to be Levelled and "Levelling Bases" set to line, level and plumb with Expanding H.D. bolts drilled into sandstone base.
- Stanchion with "blade" set up and bolted to "Levelling Base".
- Gap under baseplate grouted, including H.D. Bolt sockets.

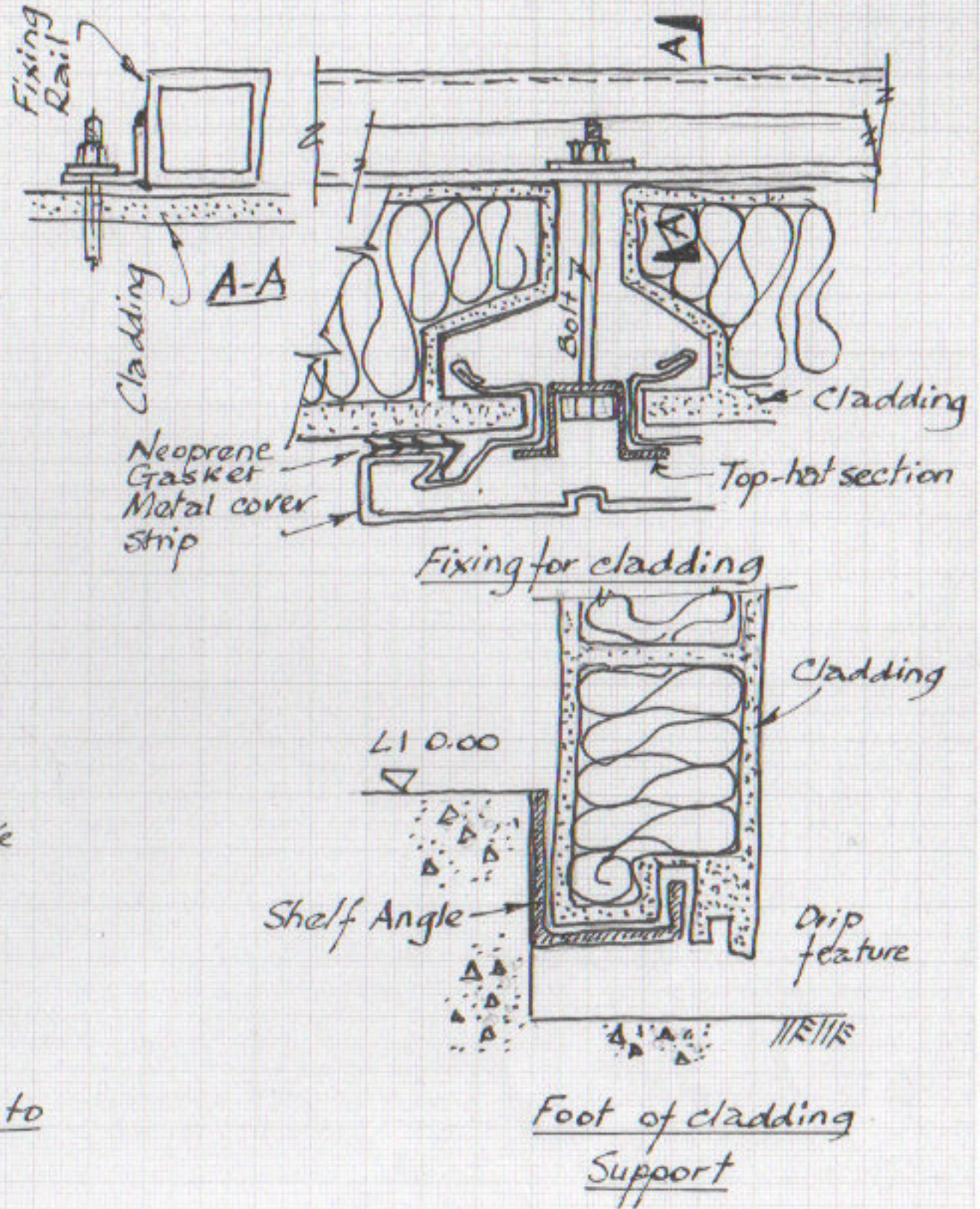

Foot of cladding Support

Q5-2014 Cliff-top House

o Option 2 - Steel-framed building is my recommended option because it provides a better use of the available plan area, The use of up-to-date technology will control the home environment [insulation and draft-proofing] better and the whole building may be dismantled and re-erected if cliff erosion threatens.

o The calculations, Section 2c, will concentrate on three aspects:

- Wind forces over the cliff-top,
- Foundation anchorage to prevent the building being blown over,
- The strength of the vertical and horizontal framing.

o Wind: CP3: Chapter V: Part 2: 1972: Appendix D'

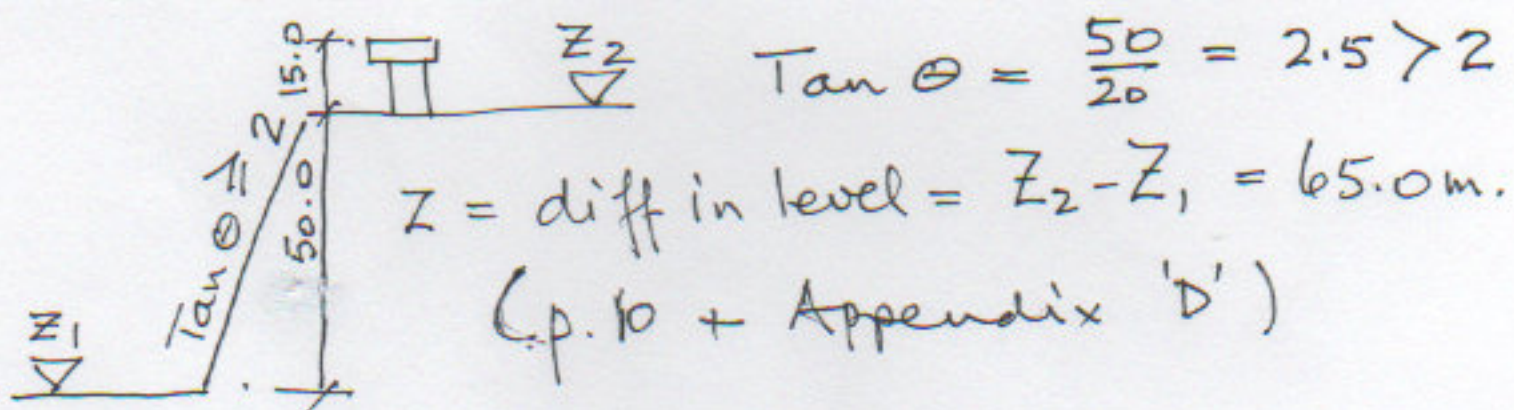

Wind load on structure as a whole

$$\therefore \text{Dynamic wind speed} = V \times S_1 \times S_2 \times S_3$$

V_s

Ref. 5.4 $S_1 = 1.1$

Ref 5.5.2 Class 'B' $S_2 = 1.13$

Table 3

Height = 65.0m

Ground roughness = (1) "no obstructions"

Ref. 5.6 Equivalent exposure assumed to be 50 years

But this structure may be expected to be exposed for a longer period.

Ref. Appendix 'c': probability level 0.01
 $\therefore S_3 = 1.35$

Hence dynamic wind speed $V_s = 52.0 \frac{\text{m}}{\text{sec}} \times 1.1 \times 1.13 \times 1.35$
(3 second gust) $= 1.678 \times V_s$

[Not on Table 4!] $= 87.3 \text{ m/sec}$

\therefore Dynamic pressure $q = k V_s^2$

$k = 0.613$ in S.I. Units N/m^2 and m/sec .

$\therefore q = 0.613 \times 87.3^2 = 4672 \text{ N/m}^2$
 $\equiv 4.672 \text{ kN/m}^2$!

Assuming that all surfaces are rough or have projections $V_{sb} = 87.3 \times 8 \gg 6$

H/b ratio $= \frac{15}{8} = 1.875$.

$\therefore C_f = 0.7$ Force coefficient on circular plan

\therefore Total wind load on this building

$= F = C_f \cdot q \cdot 15.0 \times 8.0 = 0.7 \times 4.67 \times 15 \times 8 \text{ kN}$
 $= 392 \text{ kN}$

Acting at $15/2$

\therefore Moment $= 392 \times \frac{15}{2} = \underline{\underline{2942 \text{ kN m}}}$

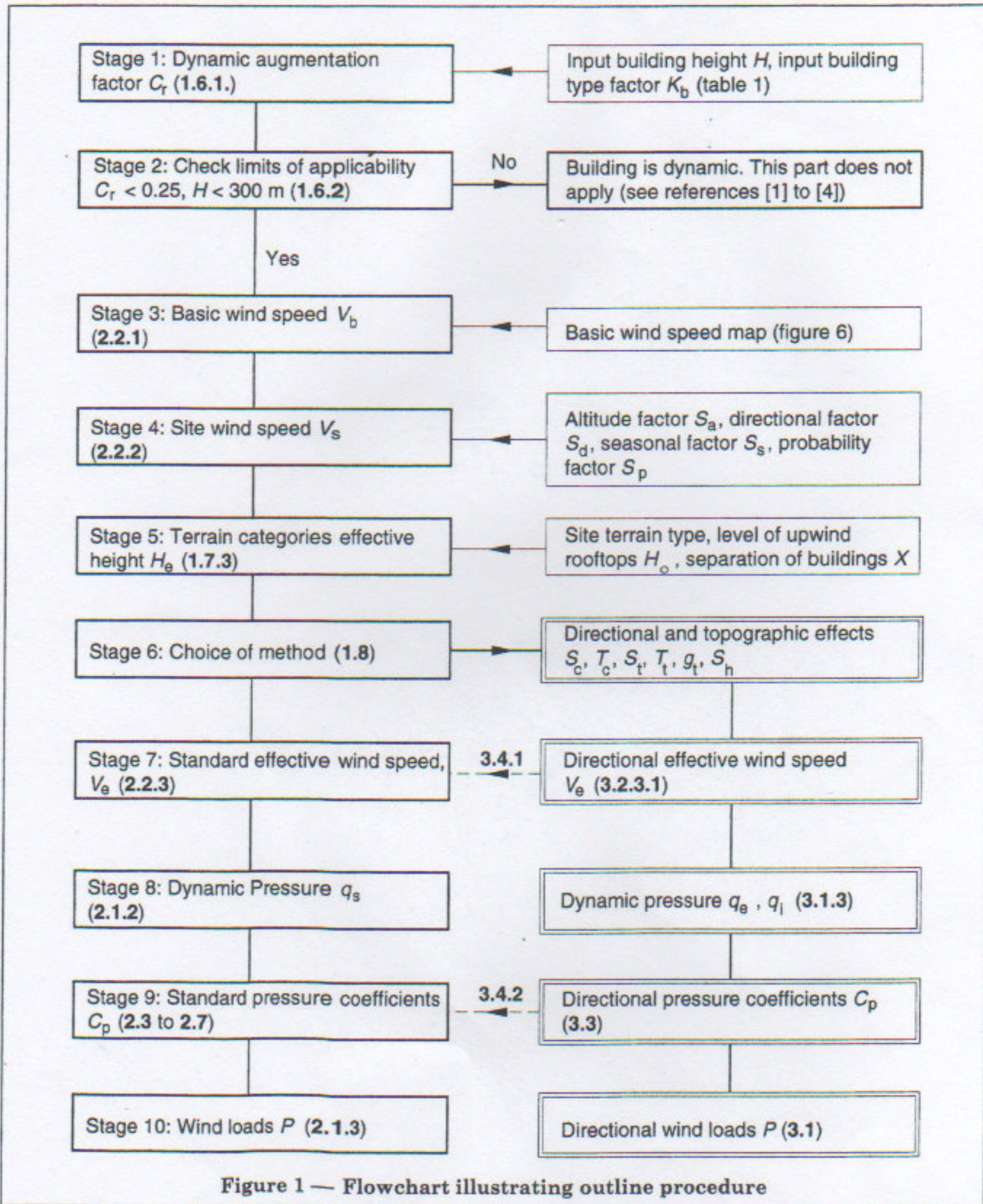
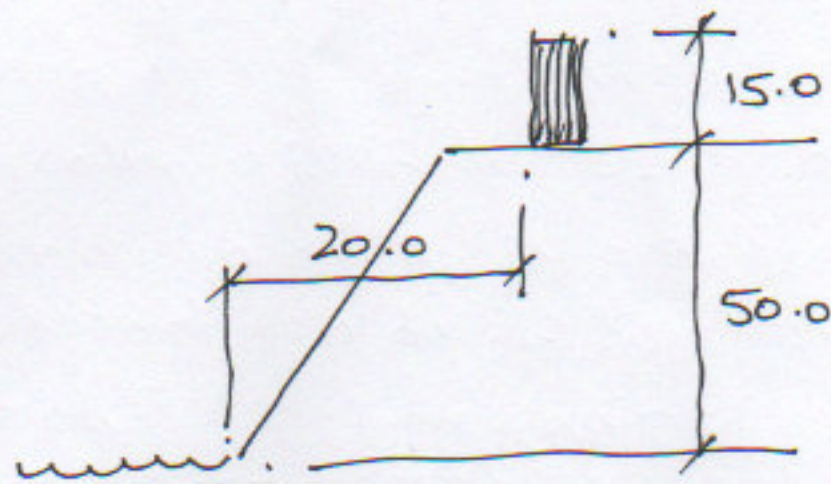

Figure 1 — Flowchart illustrating outline procedure

Using BS 6399-2:1997



Using "Standard Method" Ref. Fig 1 - Flowchart

Stage 1: Topography is significant (1.3.3.1)
Effective height = 50.0 (1.3.3.5)

Stage 2: Is the building dynamic? The response of a structure to the variable action of wind can be separated into two components, a background component and a resonant component. The background component involves static deflection of the structure under the wind pressure. The resonant component, on the other hand, involves dynamic vibration of the structure in response to changes in wind pressure. In most structures, the resonant component is relatively small and structural response to wind forces is treated using static methods of analysis alone. (See "Reinforced and Prestressed Concrete Design", O'Brien and Dixon, 1995, ISBN 0-582-21883-7).

Probably not!

Stage 2
(cont.)

Let $K_b = 0.5$ - Building of masonry
Timber-framed housing
(Table 1)

Dynamic augmentation factor (Fig. 3)

$$H = 15.0 \text{ m} \quad K_b = 0.5 \rightarrow C_r = 0.01 < 0.25$$

(Fig. 1)

Employ equivalent static loads (1.6.1)

Stage 3

Basic wind speed, V_b , given in question
 $V_b = 26.0 \text{ m/s}$ (location Western Scotland)

Stage 4

Site wind speed, $V_s = V_b \times S_a \times S_d \times S_s \times S_p$
(2.2.2.1)

Significant Topography

$$L_e = \frac{Z}{0.3} = \frac{50}{0.3} = 167 \quad \text{Then } \frac{X}{L_e} = \frac{50}{167} = 0.3$$

$$\frac{H}{L_e} = \frac{15}{167} = 0.089$$

From Fig. 10 b $s = 0.62$

$$S_a = 1 + 0.001 \times 50 = 1.05$$

$$\text{or } S_a = 1 + (0.001 \times 0) + \left(1.2 \times \frac{50}{20} \times 0.62\right) = 2.86$$

Greater!

The orientation of the building is unknown

$$\therefore S_d = 1.00$$

The building is permanent

$$\therefore S_s = 1.00$$

For the standard risk value ($\alpha = 0.02$), $S_p = 1.00$

$$\therefore V_s = 26 \times 2.86 \times 1.0 \times 1.0 \times 1.0 = \underline{\underline{74.36}} \text{ m/s}$$

= site wind speed.

Stage 7 Effective wind speed $V_e = V_s \times S_b$ (2.2.3.1)
 $H_e =$ maximum height of the building = 15.0 m
(1.7.3)

Site is in country ≤ 0.1 km downwind
of the sea (Table 4) $\therefore S_b = 1.85$

$$\therefore V_e = 74.36 \times 1.85 = \underline{\underline{137.566}} \text{ m/s}$$

Stage 8 Dynamic pressure, $q_s = 0.613 V_e^2 \text{ N/m}^2$
 V_e outside range of table 2

$$\therefore q_s = \frac{0.613 \times 138 \times 138}{1000} = \underline{\underline{11.67}} \text{ kN/m}^2$$

Stage 9 Circular-plan building (2.4.6) surface
rough.

$$H = 15.0 \text{ m} \quad d = 8.0 \text{ m} \quad \frac{H}{d} = \frac{15}{8.0} = 1.875 < 2.5$$

Position on periphery:

$$0^\circ \quad C_{pe} = +1.0$$

$$70^\circ, 290^\circ \quad C_{pe} = -1.1$$

$$40^\circ \quad C_{pe} = 0.0 \pm 0.7$$

Highest risk of fatigue.

External pressure coefficients for the
roof (2.5)

Coefficients for flat roofs of circular-plan
buildings are not specifically given in
BS 6399-2, see "wind loading, a
practical guide to BS 6399-2, wind load
on buildings" by Nicholas J Cook, 1999;
reprinted with amendments 2005,
ISBN 0-7277-2755-9

Cook goes on to give a procedure using the Standard Method Zones. Zone A pressures do not occur because there are no corners; instead substitute Zone B for any areas of Zone A.

Later in the book, under Hipped roofs, p 96, he again offers a procedure for many-sided buildings that generally have "Hipped" roofs.

The Concept Designer needs to be practical and allow for future changes and alterations.

BS 6399-2 can produce unnecessarily accurate answers (See Concluding Comments" on page 12 of BRE Digest 436 Part 3).

For this small-area roof and using Table 11 C_{pe} will be taken as -1.2 (indicating suction).

Stage 10 wind loads (2.1.3)

$$p_e = q_s C_{pe} C_a \quad C_a (\text{Fig 4} = 1.0)$$

$$= 11.67 \times 1.1 \times 1.0 = \underline{\underline{12.84 \text{ kN/m}^2}} \text{ on walls}$$

$$p_{e \text{ roof}} = 11.67 \times -ve 1.2 \times 1.0 = 14.00 \text{ kN/m}^2$$

Suction
on roof.

This is equivalent to 560 mm of concrete slabs!

In conclusion:

Using Chapter V

$$V_s = 87.3 \text{ m/sec}$$
$$q_r = 4.672 \text{ kN/m}^2$$
$$C_f = 0.7$$
$$F \text{ on walls} = \underline{\underline{392 \text{ kN.}}}$$

Using 6399

$$V_s = 74.36 \text{ m/sec}$$
$$V_e = 137.6 \text{ m/sec}$$
$$q_{rs} = 11.67 \text{ kN/m}^2$$

$$C_{pe} = +1.1$$

or -1.1 on roof.

$$P_e \text{ walls} = 12.84 \text{ kN/m}^2$$
$$P_e \text{ roof} = -ve 14.0 \text{ kN/m}^2$$

(suction)

$$\therefore F \text{ on walls} = (C_{pe} \times q_{rs}) \times 15 \times 8.0$$
$$= 12.84 \times 15 \times 8.0 = \underline{\underline{1540 \text{ kN. walls}}}$$

$$F \text{ on roof} = -1.1 \times 11.67 \times \frac{\pi}{4} \times 8.0^2$$
$$= -14.0 \times \frac{\pi}{4} \times 8 \times 8.0 = \underline{\underline{645 \text{ kN uplift}}}$$

All-in-all the wind forces appear to be about four times stronger than when using Ch. V and nearly fifteen times stronger than the basic assumption often used in the Examination [of 1.0 to 1.2 kN/m^2 in a relatively sheltered location]. The answer to this question is governed by the wind loading!

Considering the Roof:

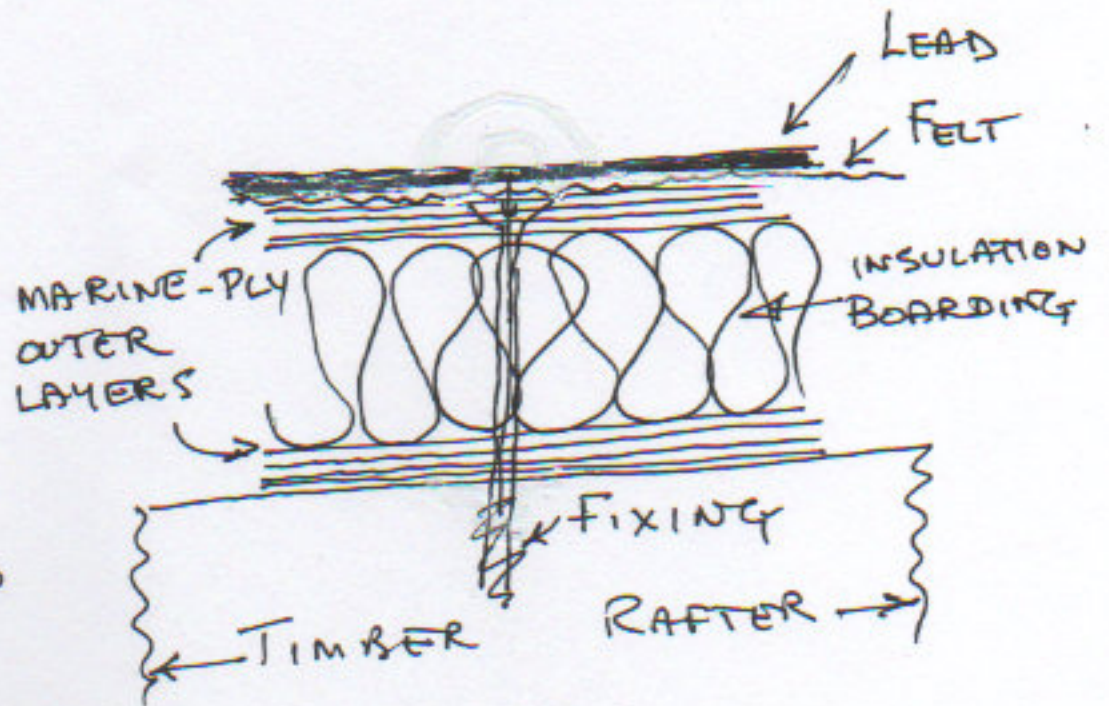
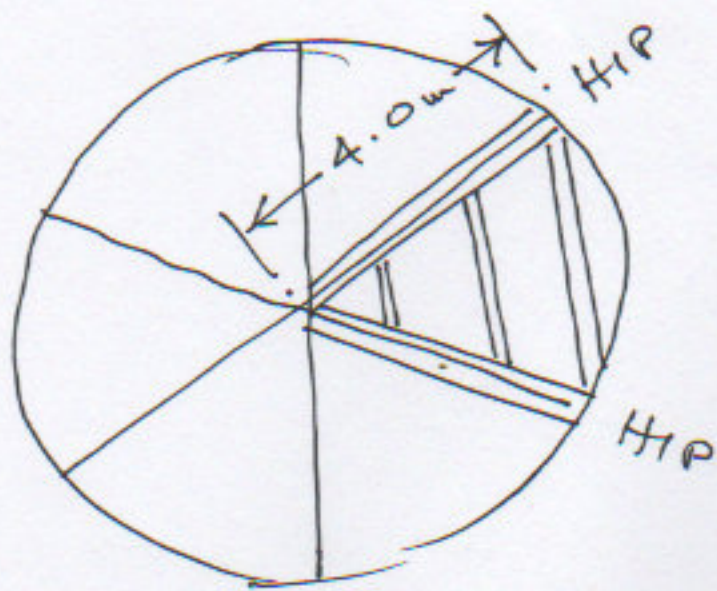

FIXINGS WITH BRASS SCREWS THAT PREVENT ELECTROLYTIC ACTION.

ROOFING FELT LAID BETWEEN THE BOARDING AND THE LEAD SHEET - ALLOWS EXPANSION / CONTRACTION MOVEMENT AND DEADENS THE SOUND OF WIND AND RAIN. IT ALSO PROVIDES VENTILLATION UNDER THE LEAD SHEET

MILLED LEAD SHEET IS SUPPLIED BY THE MANUFACTURER CUT TO DIMENSIONS AS REQUIRED OR IN LEAD ROLLS - FLASHINGS AND WEATHERING APPLICATIONS

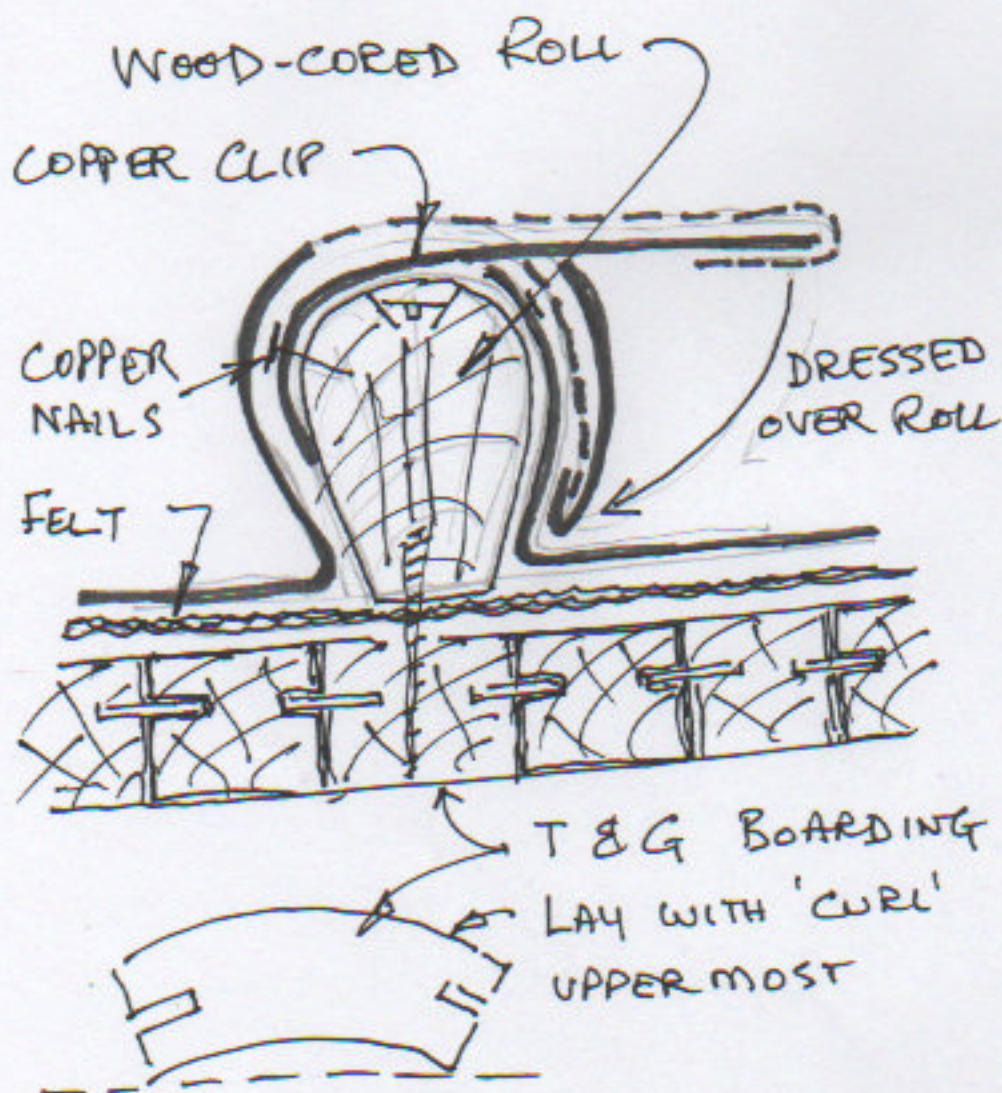

THE ENGINEER NEEDS TO KNOW THAT THE LEAD SHEETING WILL BE SECURELY HELD DOWN IN A STORM.

LEAD SHEETING IS NATURALLY RESISTANT TO CORROSION IN COASTAL AREAS.

THE EXTRA WEIGHT OF CODE 8 SHEET WILL ASSIST IN RESISTING THE WIND SUCTION.

REF: "FLAT ROOFING - DESIGN & GOOD PRACTICE", CIRIA, 1993
ISBN 0-86017-3453

The uplift force on the roof due to wind is estimated to be 645 kN. (See page 26).

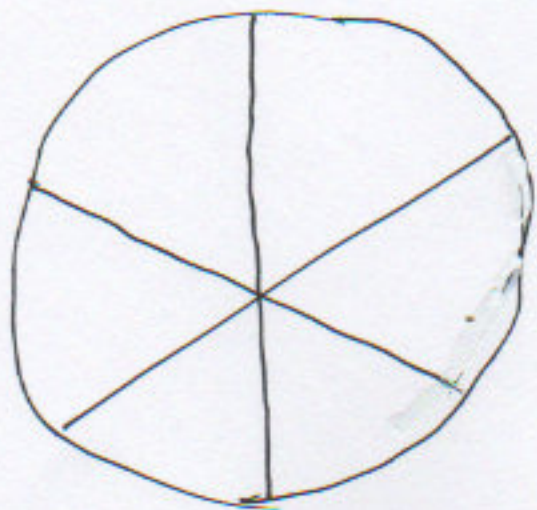

As currently envisaged there are six equal roof supports with either a stone wall under (Option 1) or six vertical frames (Option 2)

F.o.S.

$$\therefore \text{Anchorage force} = \frac{645 \times 1.5}{6} = 162 \text{ kN. each.}$$

$$\text{Allow a tensile strength} = 275 \text{ N/mm}^2$$

$$\text{Area required at each tie} = \frac{162 \times 1000}{275} = 589 \text{ mm}^2$$

$$\text{Using mild steel flat Try } 100 \times 8 \text{ tk} = 800 \text{ mm}^2$$

$$\text{--- " --- " --- round Try } 30 \phi = 707 \text{ mm}^2$$

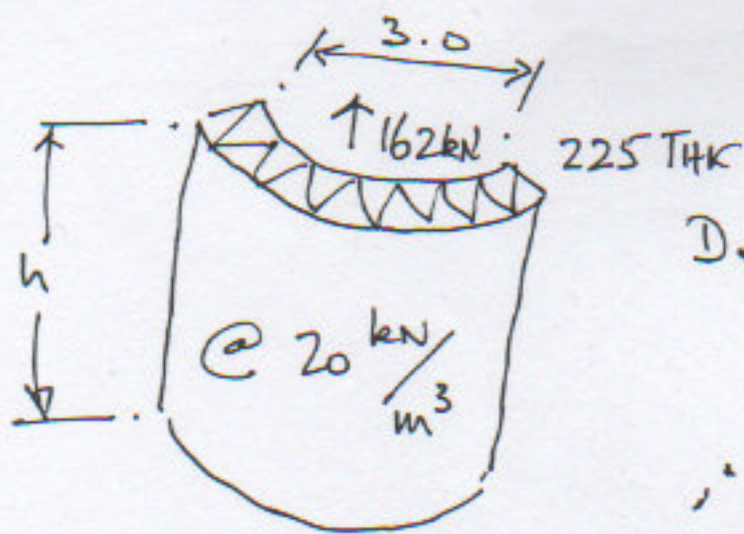

Dead weight of wall =

$$162 = h \times 3.0 \times 0.225 \times 20$$

$$\therefore h = \frac{162}{3.0 \times 0.225 \times 20} = \underline{\underline{12 \text{ m.}}}$$

This would require the full height of the house unless both masonry walls could be used. In Option 2 the steel frames will be bolted down into the available sandstone; a form of "rock bolting" appears to be appropriate and specialist advice would be sought.

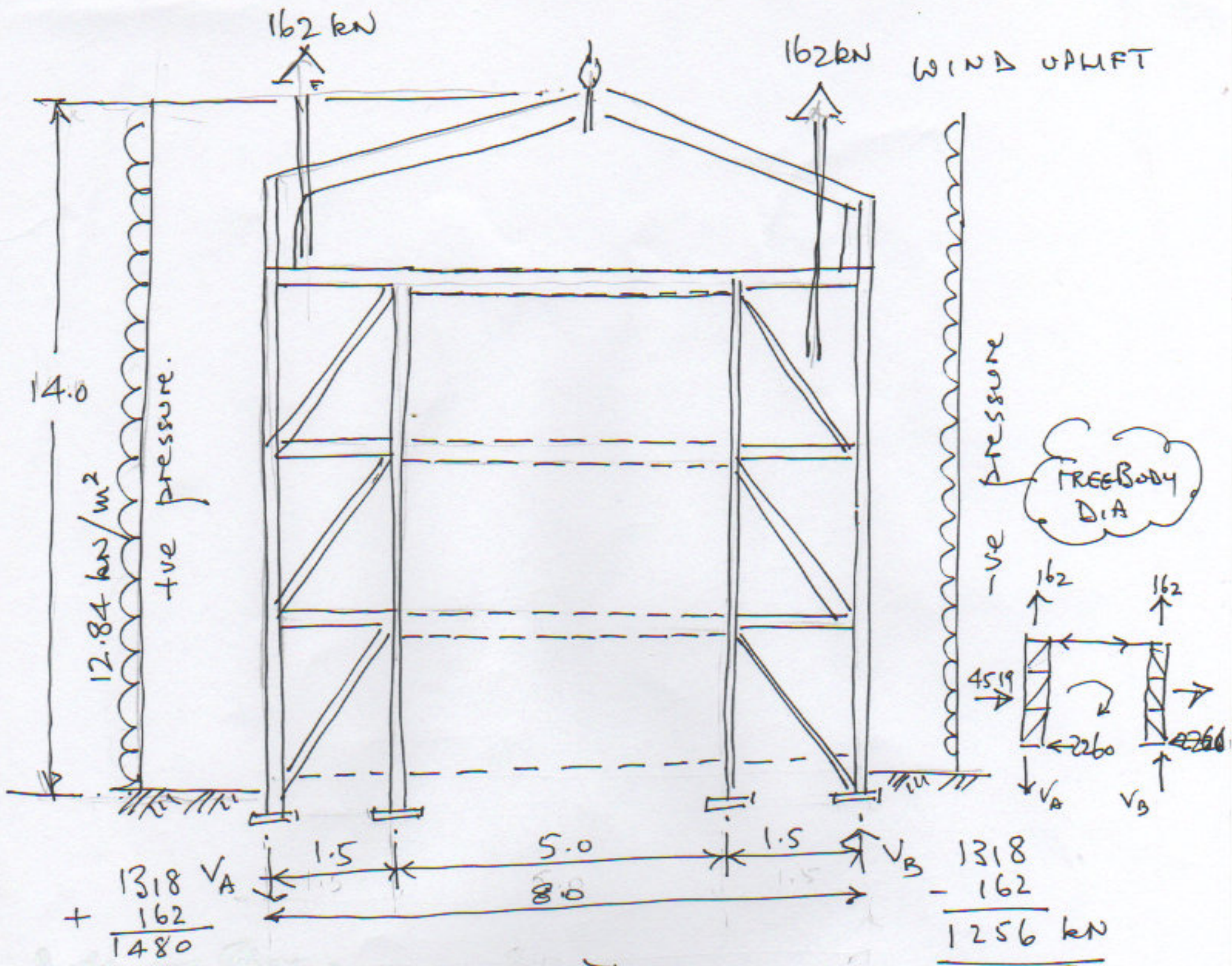

Lateral Force:

$$2 \times 14 \times 12.57 \times 12.84 \text{ kN}$$

$$= 4519 \text{ kN.}$$

Overturning Effect

$$= 4519 \times \frac{14}{2}$$

$$= 31633 \text{ kN m.}$$

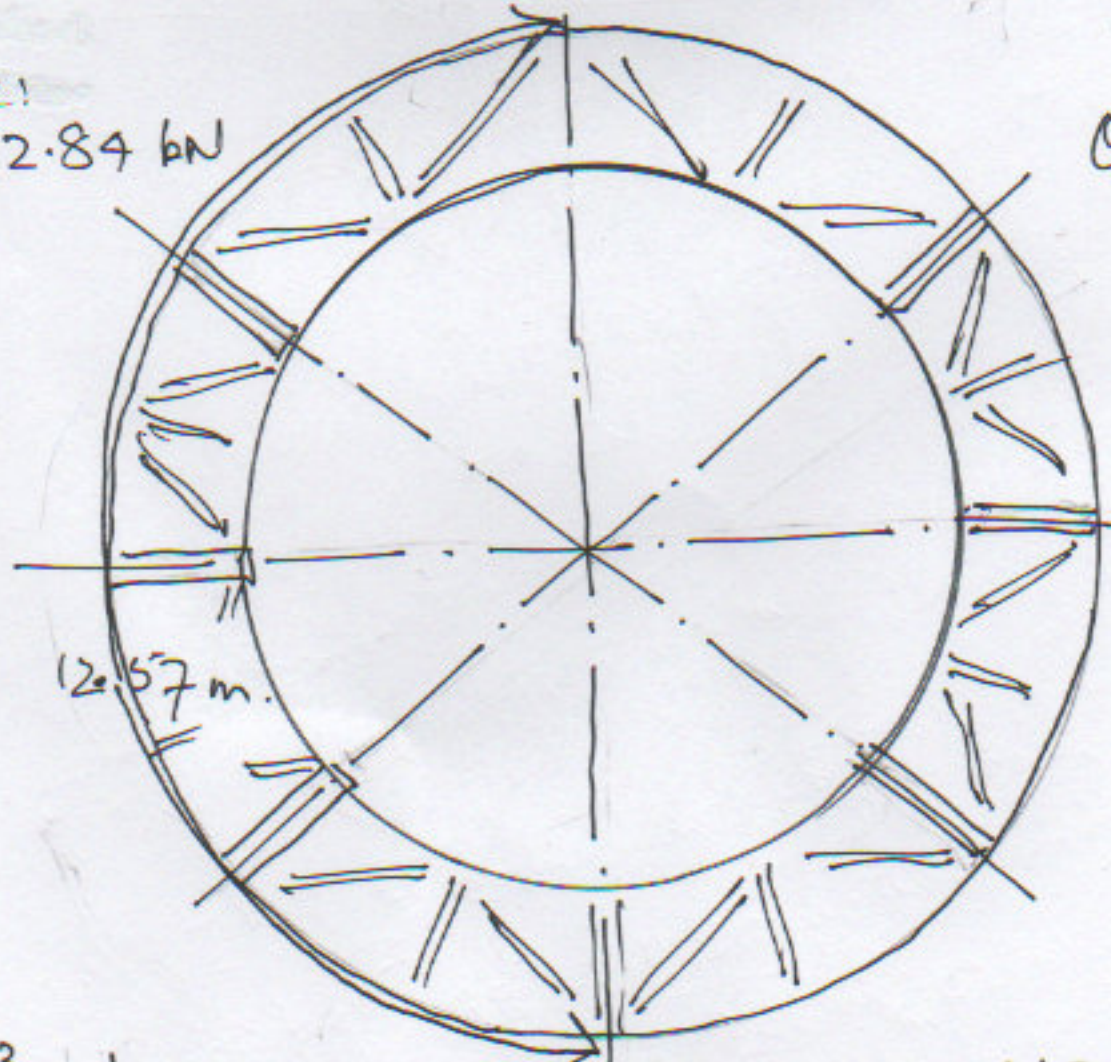

$$D_{ce} = \pi \cdot D = \pi \times 8.0$$

$$= 25.13 \text{ m.}$$

$$\frac{D_{ce}}{2} = 12.57 \text{ m.}$$

$$V_A = V_B = \frac{31633}{8.0} \times \frac{1}{3}$$

$$= \underline{\underline{1318 \text{ kN}}}$$

Max Compression = 1480 kN

Min Compression = 1256 kN.

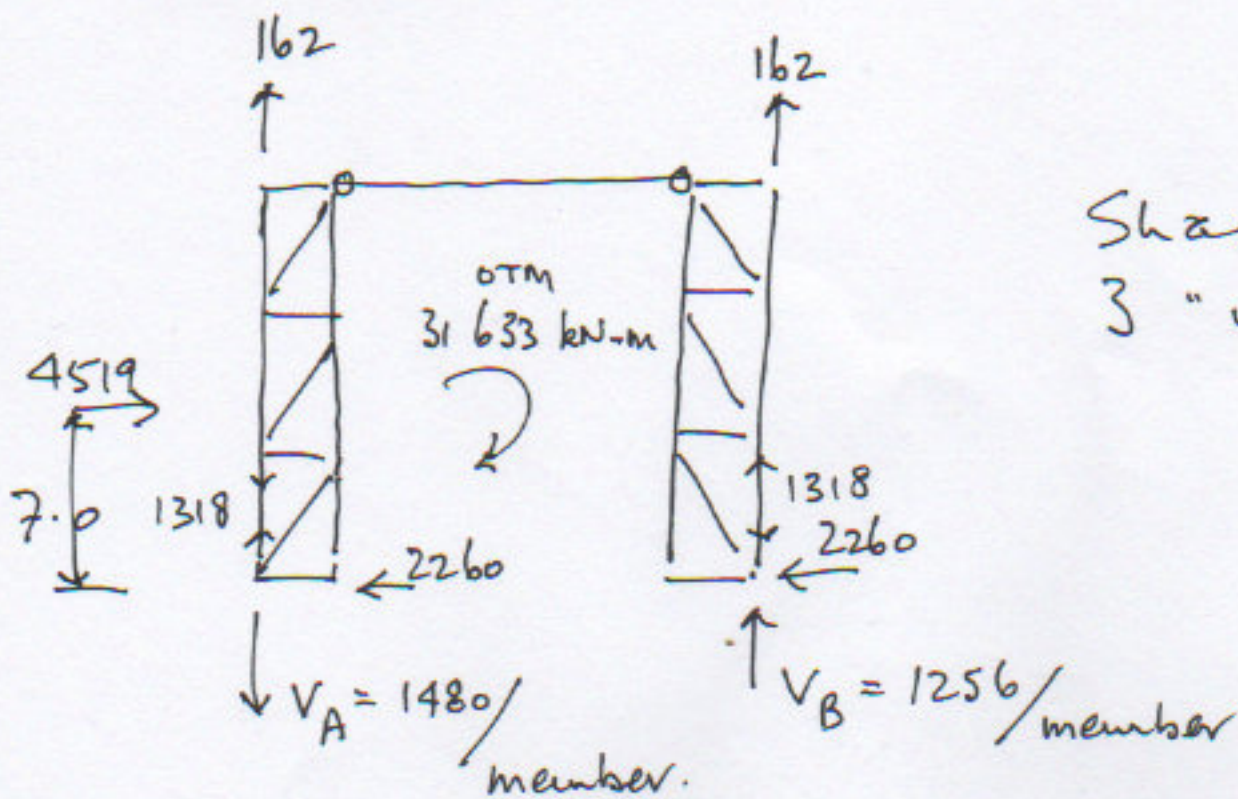

Shared equally between 3 "members".

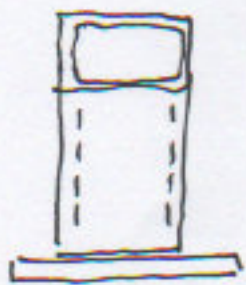

↓ 1480 kN.

Try HS 100 x 6.3 thk. [As on drawing]

$$A = 23.2 \text{ cm}^2$$

$$\frac{1480 \times 1000}{23.2 \times 100} = 638 \text{ N/mm}^2 \left[\begin{array}{l} \text{Factored.} \\ \text{ref. p. 28} \end{array} \right]$$

Steel Grade S355 for Hollow sections.

$$f_t = 638 \text{ N/mm}^2 > 355 \text{ N/mm}^2$$

$$\text{Area required} = \frac{1480 \times 1000}{355 \times 100} = 41.69 \text{ cm}^2$$

Use 140 x 140 x 8 thk SHS. A = 41.6 cm²

Check as a strut Length = 2.767 m [as on drawing]

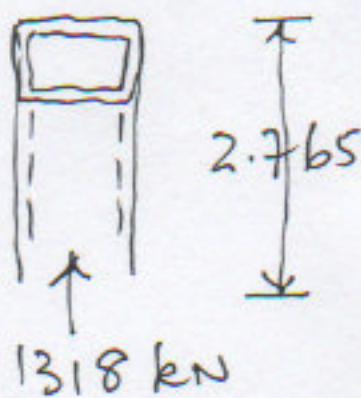

Blue Book:

$$\begin{aligned} \text{Buckling length} &= 2.0 \text{ m. } N_b = 1370 \text{ kN} \\ &= 3.0 \text{ m. } N_b = 1230 \text{ kN.} \end{aligned}$$

May be necessary to use thicker section 10 thk @ 3.0 m $N_b = \underline{\underline{1490 \text{ kN}}}$

N.B Modify drawing to 140 SHS 10th.
(30)