



Possible solution to past CM examination question

**Question 1 - April 2008**

**Sports Arena**

by Dr Peter Gardner

The information provided should be seen as an interpretation of the brief and a possible solution to a past question offered by an experienced engineer with knowledge of the examiners' expectations (i.e. it's an individual's interpretation of the brief leading to one of a number of possible solutions rather than the definitive "correct" or "model" answer).

# Question 1. Sports Arena

## Client's requirements

1. A circular sports arena is to be built on a vacant site; see Figure Q1.
2. The Client has specified that the building shall be 80.0m in diameter internally. The height of the underside of the roof is to be a minimum of 18.0m above the floor in the centre and 20.0m at the perimeter of the arena. The interior of the arena shall be column free.
3. The roof over the arena is to be a lightweight structure and should be of a pleasing appearance.
4. Around the perimeter of the arena is a permanent structure that supports the seating and provides accommodation at level 1 for offices and public amenities and at level 2 for storage. The seating will be made of precast concrete planks which have a maximum span of 8.0m.
5. A 5.0m wide by 4.0m high clear access way is located around the perimeter of level 1 and level 2 shown shaded in Fig.Q1. The area under the sloping seating at level 2 is for storage only and there are no restrictions on the placement of structure in this area.
6. The Client wishes to retain flexibility of use within level 1 of the permanent perimeter structure and has stipulated that the area will be completely unobstructed other than for two lines of internal columns on concentric grid lines measured from the centre of the arena. A minimum spacing of 6.0m between column centres shall be maintained in all directions. A minimum clear height to underside of structure of 4.0m is required throughout. There are no limits on column spacing around the perimeter wall, which is to be clad in masonry.

## Imposed Loading

- |                      |  |
|----------------------|--|
| 7. Roof              | 0.6kN/m <sup>2</sup>   |
| Floor levels 2 and 3 | 5.0kN/m <sup>2</sup>   |
| Seating Area         | Precast planks dead load of 8.0kN/m <sup>2</sup> and live load of 5.0kN/m <sup>2</sup> |
| Floor level 1        | 20.0kN/m <sup>2</sup>  |
- Loadings include an allowance for partitions, finishes, services and ceilings.

## Site Conditions

8. The site is level and located on the edge of a major city centre. The site has a public parking area on all sides. Basic wind speed is 40m/s based on a 3 second gust; the equivalent mean hourly wind speed is 20m/s.  
Ground conditions

|            |               |  |
|------------|---------------|--|
| Borehole 1 | Ground - 2.0m | Made ground (fill)                                       |
|            | 2.0m-8.0m     | Stiff clay. C=90kN/m <sup>2</sup>                        |
|            | Below 8.0m    | Rock. Allowable bearing pressure = 1000kN/m <sup>2</sup> |
| Borehole 2 | Ground - 4.0m | Made ground  |
|            | 4.0m -10.0m   | Stiff clay. C=80kN/m <sup>2</sup>                        |
|            | Below 10.0m   | Rock. Allowable bearing pressure = 1000kN/m <sup>2</sup> |

Ground conditions change linearly between the 2 boreholes and groundwater was not encountered.

## Omit from consideration

9. Detailed design of staircase, precast seating planks and specialist finishes to level 1 floor.

*continued overleaf*

**SECTION 1****(50 marks)**

- a. Prepare a design appraisal with appropriate sketches indicating two distinct and viable solutions for the proposed structure including the foundations. Indicate clearly the functional framing, load transfer and stability aspects of each scheme. Identify the solution you recommend, giving reasons for your choice. (40 marks)
- b. After the design has been completed, the Client advises you that he wishes to hang a large advertising and lighting box weighing 50 tonnes from the middle of the roof. Write a letter to the Client explaining how this might be achieved. (10 marks)

**SECTION 2****(50 marks)**

For the solution recommended in Section 1(a):

- c. Prepare sufficient design calculations to establish the form and size of all the principal structural elements including the foundations. (20 marks)
- d. Prepare general arrangement plans, sections and elevations to show the dimensions, layout and disposition of the structural elements and critical details for estimating purposes. (20 marks)
- e. Prepare a detailed method statement for the safe construction of the building and an outline construction programme. (10 marks)

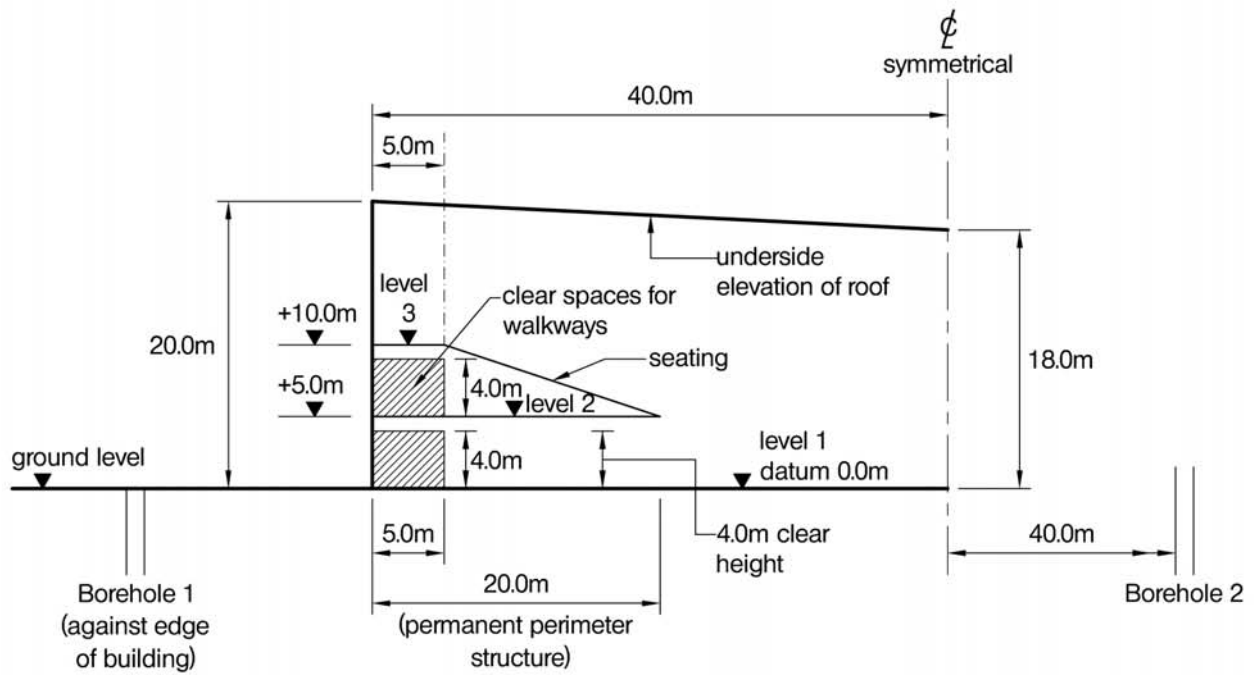

TYPICAL SECTION THROUGH ARENA

NOTE: All dimensions are in metres

FIGURE Q1

## **Introduction**

This is a relatively straightforward question but it concerns a very large, long-span structure which is likely to be outside the experience of most graduate engineers. It consists of a circular sports arena of 80 metres diameter with an unobstructed/unsupported clear span and a permanent internal perimeter structure, primarily to provide seating, but also circulation walkways and storage.

The roof span contains the greatest complexity. Questions of this nature, with a fixed geometry and a large single span, at first reading can appear to offer very limited options for alternative schemes; however a little thought will often provide distinct structural options. This thinking process should take place very early on in your initial assessment of a question. If you're really in a situation where the brief limits you to a single "obvious" solution then you should think very carefully about continuing, as the questions clearly ask for "two distinct and viable solutions". In this case I believe there are many clear viable alternatives within the constraints of the question.

## **The issues**

- Circular building of 80 metres diameter.
- No internal support at all.
- Variable clear internal height.
  
- Permanent perimeter structure providing seating, offices, circulation and storage.
- Maximum span of 8 metres for seating (probably safest to make any support with a maximum spacing of 8 metres).
- Two clear access walkways, both 5m x 4m.
- Storage area under the seating has no structural restriction (requirement five)
  
- Potentially contradictory requirements in relation to level one of the permanent perimeter structure with requirement for it to be unobstructed other than for two lines of internal columns on concentric circular grids (requirement six).
- A minimum of six metres between columns in all directions. A minimum clear height to the underside of both level one and level two structures of 4 metres (consistent with requirement for walkways).
  
- There are no limits on external columns.
- External elevation to the masonry (stability system?)
  
- There are no constraints in relation to the site (vacant and accessible).
  
- Substantial quantity of made ground, overlying stiff clay which itself overlies rock with a substantial ground bearing pressure.
- Profile varies across the site, with no ground water.
- We are likely to have a substantial structure which should probably be founded on the rock.
- The depth of made ground will necessitate an engineered ground floor slab.

## **Interpretation of the brief**

The question probably breaks down to four sections, with only the main roof structure likely to cause any significant difficulty. The four elements are: the 80 metres clear span roof, the seating area, the stability system and the perimeter wall, the foundation system & ground floor.

As far as the roof is concerned, we have a large span with a varying clear height. This allows us to provide greater depth in the centre, thus although it's not a requirement in terms of satisfying the brief, it would seem sensible to follow the internal profile. It would be difficult to provide a satisfactory answer to this question without providing significantly different structural schemes for the roof.

There is no constraint on the external dimensions of the structure, allowing us a completely free hand outside the envelope specified in the question.

The walkways and seating provide the only significant constraints in terms of the brief, but there is nothing here that should cause us any difficulty. This element could form part of the overall stability system, or could just satisfy its own functional requirements.

The whole structure is clad in masonry, the support of which will need to be considered.

## **The superstructure and two distinct and viable solutions**

Despite the structure's size and pre-defined geometry there is significant possible variation in the superstructure and the associated stability system. My initial thoughts go along the lines of using the circular shape to provide a ring beam to resist forces from the roof structure (arch etc), or a relatively simple beam and stick with an independent stability system, or some variant on a portal frame. Even at the preliminary stage, there are so many possibilities that the problem becomes narrowing them down in a form that can be presented in a time-constrained answer, rather than scratching your head for a second scheme.

Although the geometry (circular structure) provides opportunities for a 3D structure consisting of radial elements, it also gives us the difficulty of multiple beams meeting at the centre. This is likely to be an issue for every option other than simple 2D frames. This may lead us to consider some form of central ring beam which picks up any structural elements converging at the centre, but clearly it would be very difficult to transmit bending with this configuration.

Developing the ring beam idea, leads us to a variety of options of domes or arches in compression where the ring beam resists the horizontal thrust, or tension structures where the ring beam holds the roof elements apart.

A combination of individual trusses, supported on the lattice stanchions would provide a very straightforward and simple-to-analyse arrangement.

Some form of portalised truss would provide inherent stability, and could easily accommodate the spans we are dealing with. This could be modified to a three pinned arch, or a combination of towers and cables supporting a light-weight roof structure.

The geometry is well-suited to a true 3D roof, whether it be an arch, a tension structure or a more traditional 3D space frame, but of course this arrangement would be virtually impossible to design by hand (for the purposes of the exam).

Drainage could be an issue with some structural forms and should be taken into account.

The diagrams following this commentary develop some of these ideas.

Some of the structural arrangements proposed may be susceptible to wind up-lift. If this results in load reversal, and you haven't identified this possibility, you have a potentially serious flaw in your proposal. This is always an issue to keep in the back of your mind.

## **Stability**

There are two fundamental options for the stability system, either utilising a beam and stick arrangement for the principal structure, which needs an independent stability system, or alternatively using frames, that due to their geometry, have inherent stability.

The shape of the building and the lack of any large openings means there is ample opportunity for bracing between the columns, and in the roof. If frames are used that have inherent stability (three-pinned arch or portal frame), additional bracing should be provided in the walls and roof for torsional resistance and overall robustness.

## **The ground conditions, foundations and ground floor slab**

The ground conditions are relatively straightforward, with a thick layer of made ground over the site and rock below at a depth of 8 - 10m. Bearing in mind the size of the structure, it would be sensible to go straight on to the rock.

The rock is only 10 metres below ground level, and therefore some form of pad foundation would be perfectly feasible, but in reality this would just be a variation on a piled solution (it's only the construction method that would be different, the structural action would be the same, albeit that pads would provide a potentially greater area per foundation than would be readily achievable with a pile). Assuming that we have sufficient variation in the superstructure to satisfy the "two distinct and viable schemes" requirement, it would probably be sensible to propose a single foundation solution, with a discussion of possible variations on that theme.

The perimeter wall will need a significant foundation, probably using either a ring of piles, or "trench fill" constructed directly off the rock.

Because of the thickness of the made ground, the ground floor slab will need to be an engineered solution (although the surface could be grass in which case it could be potentially be applied to the existing material). Assuming the arena surface is solid, the ground floor slab and the walkways could potentially be supported from the clay (not the fill), but it would probably be more straightforward to pile into the rock for the whole structure. This would avoid any issues of differential movement between the clay and the rock. Ground improvement could be considered.

## **The letter**

The letter is straightforward in that the client wishes to hang a large advertising and lighting box from the middle of the roof, so superficially the letter could just explain how this might be achieved. However, we have a very large weight in the middle of an 80 metres span roof, which is going to have considerable implications for the structure. A client may not realise the implications of such a request and therefore some lateral thinking in relation to alternatives, to minimise the effect on the structure (in addition to explaining how the actual request might be achieved), could be beneficial.

There are many issues relating to the provision of the advertising box which gives scope for well-written helpful advice in the form of a letter to your client. As is always the case in these situations, part of the answer must respond to the client's request, whatever the structural consequences (ie it's not for the client's engineer to say this cannot be done, but to draw the client's attention to the consequences of the proposal, and offer alternatives which may produce a better/cheaper solution).

The issues that you may care to think about, and potentially build into your answer for this part of the question, could include: the significance of hanging 50 tonnes from the middle of a large clear span and the practicality of doing this as requested, deflection, investigating the possibility of achieving the same objective with less weight, providing smaller multiple advertising/lighting units which could be located away from the middle of the roof, providing an independent support system (possibly cables) with the implications of restricted visibility.

### **Summary**

The size of the overall structure, and the requirement for an 80 metres clear span, makes this a daunting structure under any circumstances, and one that is likely to be outside the individual experience of most graduate engineers. However the brief is straightforward, and doesn't contain anything that should give us particular cause for concern. As long as a candidate can find "two distinct and viable solutions", which I think the analysis above suggests is relatively straightforward, then there is no reason why any reasonably experienced candidate should not achieve a comfortable pass with this question.



# PLAN OPTIONS

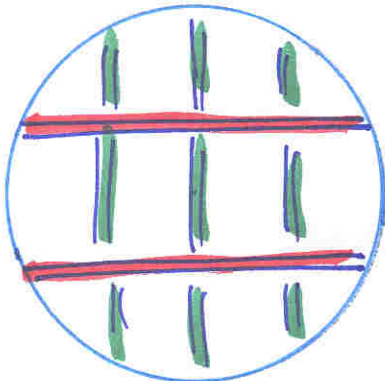

TWO MAIN BEAMS  
WITH SECONDARY  
BEAMS

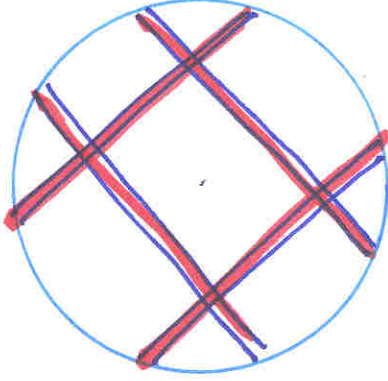
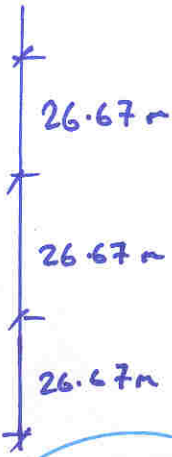

FOUR MAIN  
BEAMS / FRAMES

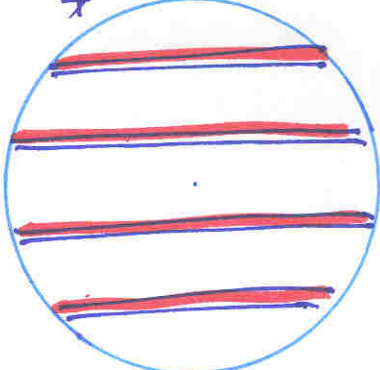

FOUR MAIN  
BEAMS / FRAMES

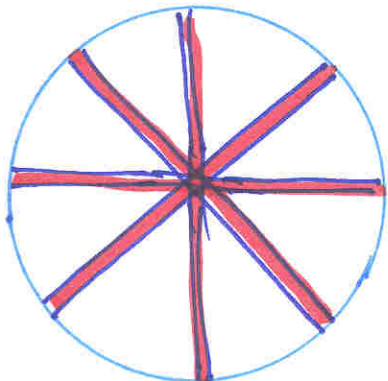

FOUR MAIN  
BEAMS / FRAMES  
(CENTRAL DOME?)

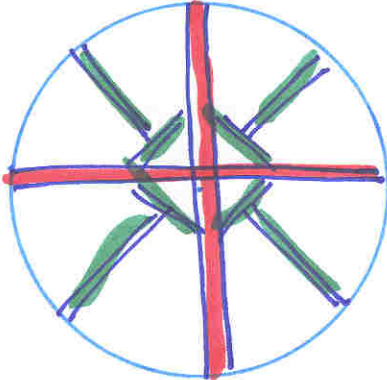

FOUR MAIN  
BEAMS  
WITH  
SECONDARY  
BEAMS

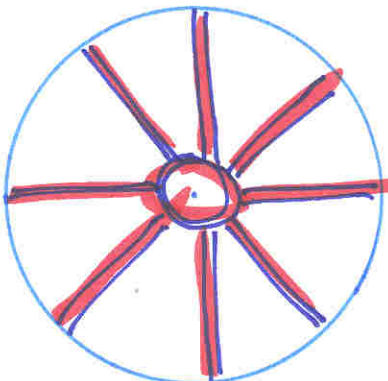

THREE PINNED  
ARCH WITH  
CENTRAL RING BEAM.

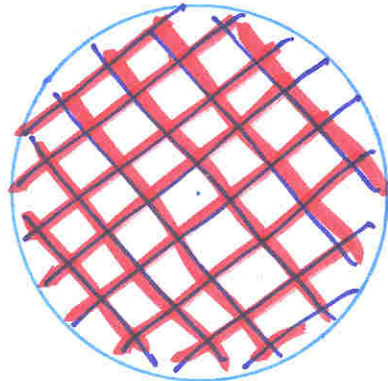

SPACE FRAME  
ROOF (3D TRUSS)

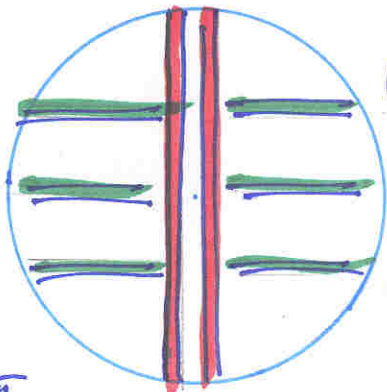

LARGE  
CENTRAL  
SUPPORTS  
(TRUSS or  
ARCH).

— MAIN SUPPORT  
— SECONDARY SUPPORT

FIXED BASE

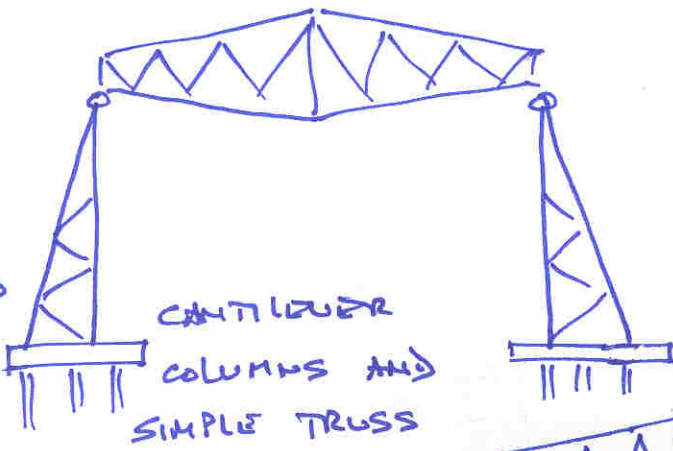

CANTILEVER COLUMNS AND SIMPLE TRUSS

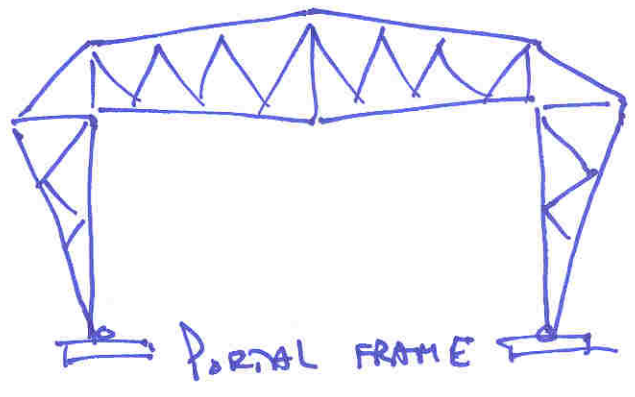

PORTAL FRAME

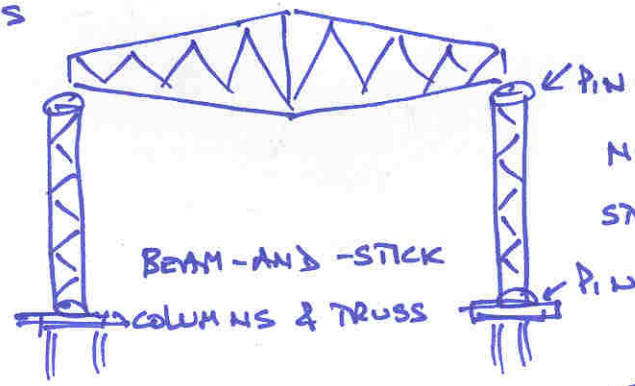

BEAM-AND-STICK COLUMNS & TRUSS

NEEDS INDEPENDENT STABILITY SYSTEM

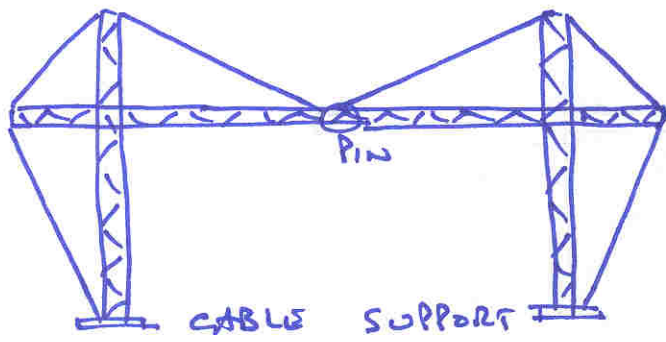

CABLE SUPPORT

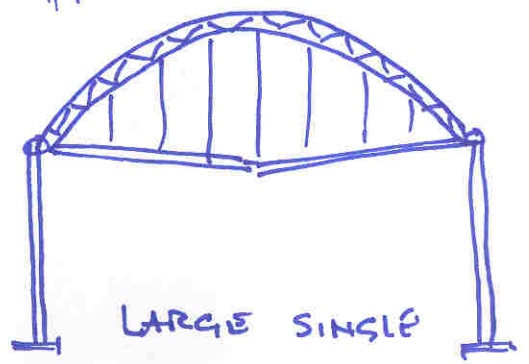

LARGE SINGLE FEATURE ARCH.

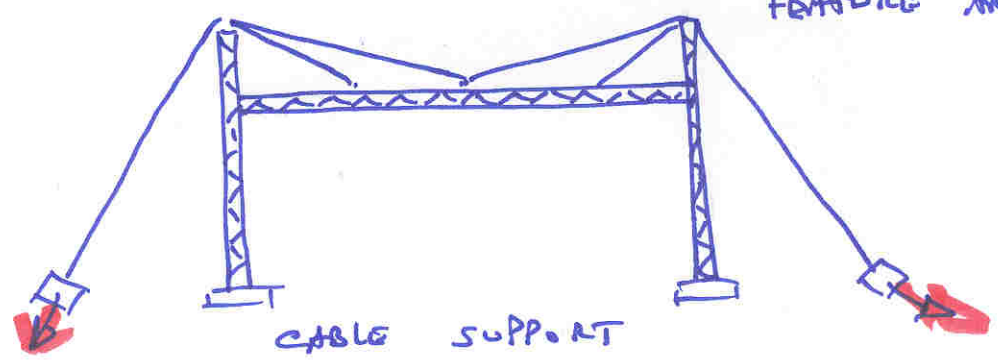

CABLE SUPPORT

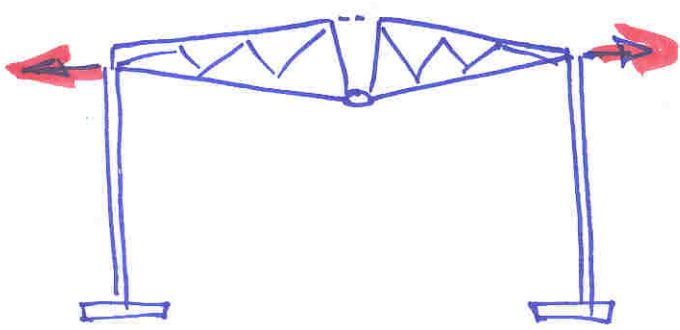

TENSION STRUCTURE

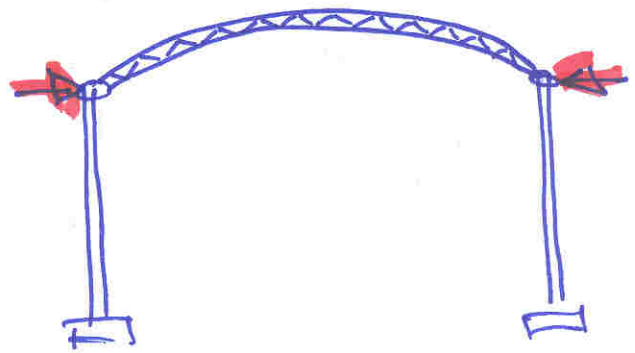

ARCH or DOME

FRAME OPTIONS



Possible solution to past CM examination question

## **Question 5 - April 2008**

### **Crocodile Tank**

by Bob Wilson



The information provided should be seen as an interpretation of the brief and a possible solution to a past question offered by an experienced engineer with knowledge of the examiners' expectations (i.e. it's an individual's interpretation of the brief leading to one of a number of possible solutions rather than the definitive "correct" or "model" answer).

# Question 5. Crocodile Tank

## Client's requirements

1. A tank is required at a wildlife centre to accommodate crocodiles. The plan area of the tank is to be between  $3600\text{m}^2$  and  $4000\text{m}^2$  and the smallest plan dimension must be at least  $40.0\text{m}$ . The tank must be of concrete construction and should be  $2.0\text{m}$  deep generally, reducing to  $1.0\text{m}$  at the perimeter. The tank will normally be filled with water but should be capable of being completely drained for maintenance.
2. Three "islands" are required in the tank, on which crocodiles may roam. Each island must be of minimum plan area  $50\text{m}^2$  and the combined plan area of the islands must not exceed  $300\text{m}^2$ . Islands must be a minimum clear distance of  $15.0\text{m}$  from the tank perimeter and a minimum clear distance of  $15.0\text{m}$  apart. The ground surface around the perimeter of each island is to be at water level and must rise to at least  $0.5\text{m}$  above water level. Structures may be supported on the islands but no structural supports of any kind are permitted elsewhere in the tank.
3. An observation tower is to be provided on one of the islands. The tower should have viewing platforms at  $4\text{m}$  and  $8\text{m}$  above water level. Each platform should have a plan area of at least  $10.0\text{m}^2$ .
4. Pedestrian access of minimum unobstructed width  $2.0\text{m}$  is to be provided from the perimeter of the tank to the observation tower.

## Imposed loading

5. Pedestrian access and viewing platforms  $5.0\text{kN/m}^2$

## Site Conditions

6. The site is level and is located in open country. Basic wind speed is  $46\text{m/s}$  based on a 3 second gust; the equivalent mean hourly wind speed is  $23\text{m/s}$ .
7. Ground conditions:  
Ground level –  $4.0\text{m}$  Sand,  $N=18$   
Below  $4.0\text{m}$  Clay,  $C=100\text{kN/m}^2$   
Ground water was encountered at  $1.0\text{m}$  below ground level

## SECTION 1

(50 marks)

- a. Prepare a design appraisal with appropriate sketches indicating two distinct and viable solutions for the proposed tank, observation tower and pedestrian access. Indicate clearly the functional framing, load transfer and stability aspects of each scheme. Identify the solution you recommend, giving reasons for your choice. (40 marks)
- b. During construction of the tank it is found that test results for concrete used in a section of the tank including the base and walls have achieved only 70% of the required design strength. Write a letter to the Client describing your proposals for dealing with this problem. (10 marks)

## SECTION 2

(50 marks)

For the solution recommended in Section 1(a):

- c. Prepare sufficient design calculations to establish the form and size of all the principal structural elements including the foundations. (20 marks)
- d. Prepare general arrangement plans, sections and elevations to show the dimensions, layout and disposition of the structural elements and critical details for estimating purposes. (20 marks)
- e. Prepare a detailed method statement for the safe construction of the structures and an outline construction programme. (10 marks)

*There is no Figure Q5*

## Q5/2008 - CROCODILE PIT/TANK, ETC

This question, without drawings, relies on the text to express what is required from the candidate.

Allowing great freedom for an imaginative candidate it requires:

- Two geometrical shapes for the tank
- Two structural forms for the tank enclosure i.e. retaining walls.
- Two options for the observation tower
- Two options or arrangements for pedestrian access to the observation tower. Note that both access and tower are intended to be used by the public.

Following-on from these basic requirements the following considerations need to be addressed:

- Watertightness of the tank in concrete construction.
- Resistance to flotation of the tank in the high water table.
- Visitor experience and safety. These considerations will influence the aesthetics and practicalities of the access footbridges and viewing platforms.
- Maintenance de-watering and management of the crocodile stock.
- A demonstration of a knowledge of concrete technology and construction.

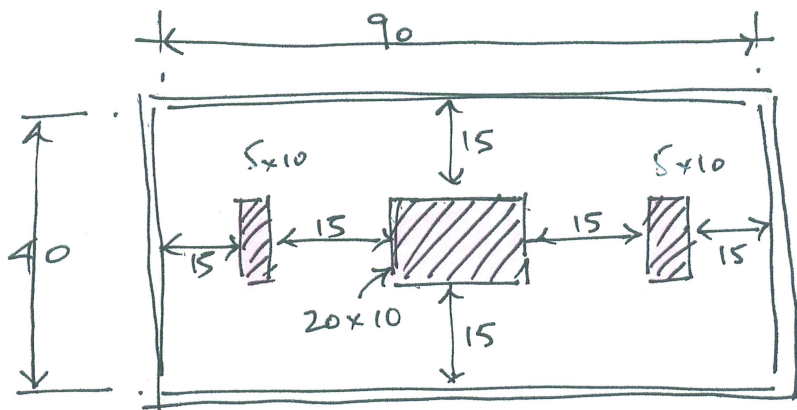
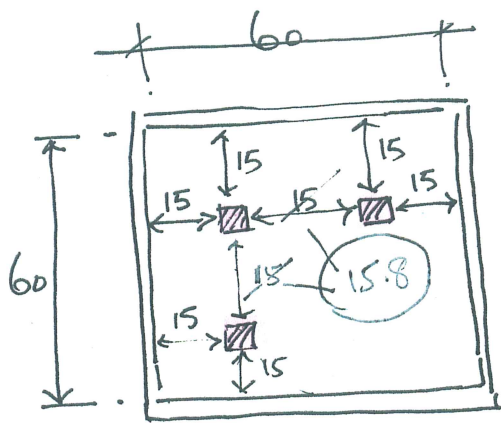

Min. Island  $50\text{m}^2 \cong 7.07\text{m}$ .

∴ tank side =  $(3 \times 15) + 2 \times (7.1)$   
 $= 59.2 > 40.0 \text{ min.}$

∴ make  $60 \times 60 = 3600\text{m}^2$ .

$60 - (2 \times 15) - (2 \times 7.1) = \underline{15.8\text{m}}$ .

Approx max span =  $15.8 + 7.1 = \underline{22.9\text{m}}$

Max. Island =  $300\text{m}^2$

Each end island  $50\text{m}^2$

Centre island =  $200\text{m}^2$

At 10m wide, length = 20m

∴ Make  $40 \times 90 = 3600\text{m}^2$

Approx max span

$= 15 + 5 = \underline{20.0\text{m}}$ .

Clearly, there are many combinations. However, it is important that an arrangement is chosen early as the configuration and sizes of the tower and its access cannot be separated.

In the rectangular tanks above two arrangements for the perimeter wall suggest themselves:

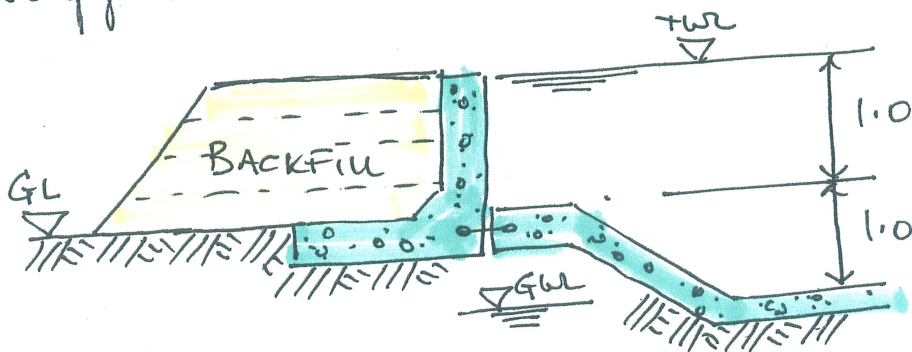
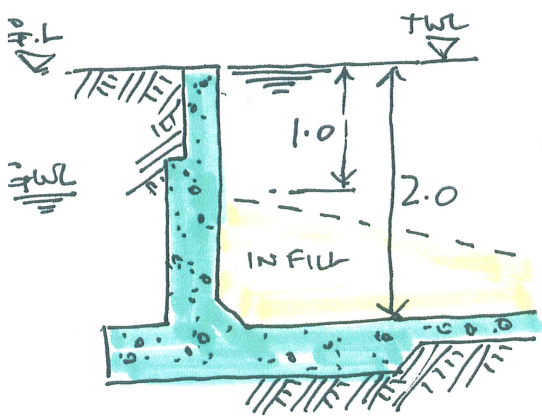

Full Excavation & CART AWAY

PARTIAL EXCAVATION USING UPRISINGS FOR BACKFILL

Arguably these are not "distinctly" different, being the same L-shaped retaining wall with different heights!

Distinctness can be achieved by proposing a circular tank with the walls acting in "hoop tension". The diameter can be between 68m and 72m. The configuration of the islands would probably be based on an equilateral triangle of 23m. side [8m diameter islands]. Hence a 68m diameter tank would be suitable. The max. span would be of the order of 25m.

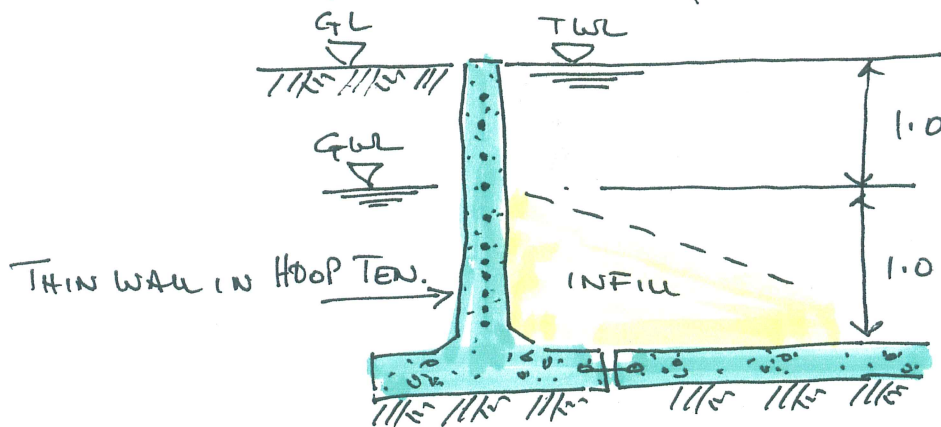

The high GWR causes the empty tank to float.

The weight of water displaced  $\approx 1 \times 40 \times 90 \times 10 = 36000$  (m<sup>3</sup>)  $\frac{\text{KN}}{\text{m}^3}$  KN.

Assuming concrete at 23 KN/m<sup>3</sup> [ $\equiv 2300 \text{ kg/m}^3$ ]

Base thickness  $\approx \frac{(36000 \times 1.1)}{23} = \frac{1722 \text{ m}^3}{40 \times 90} = 500 \text{ mm.}$

This would still be a lot of concrete to put underneath a crocodile pool!



Two alternatives suggest themselves:

1. The base of the Tank is constructed as an inverted waffle slab and infilled with rock or soil

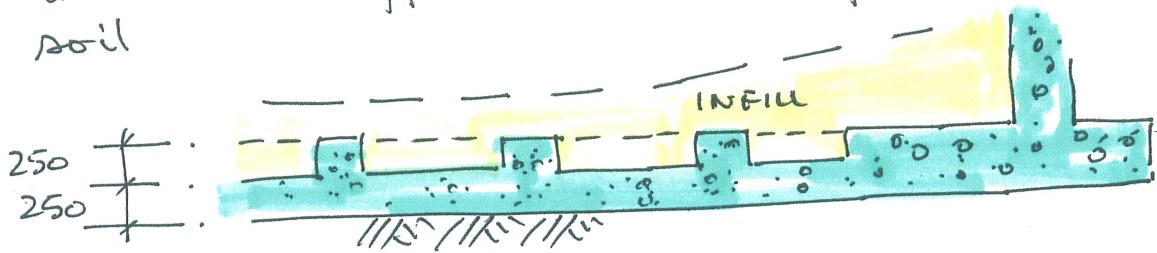

This might be better for the crocodiles but would still require extensive dewatering [well points] during construction.

2. Build the perimeter retaining wall at ground level and backfill with material excavated from within the pond down to  $-1.0m$  — the phreatic surface. This eliminates both Ground water uplift and carting-away the excavated soil. [See cross-section on page 2]

Selecting the rectangular tank shape, two arrangements for the pedestrian access would be:

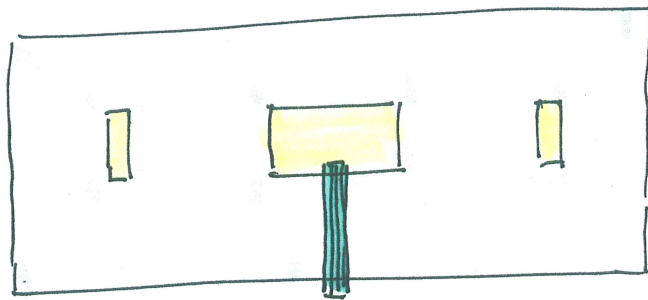

Simple "beam-type" footbridge —

- minimum structure
- minimum visitor experience.

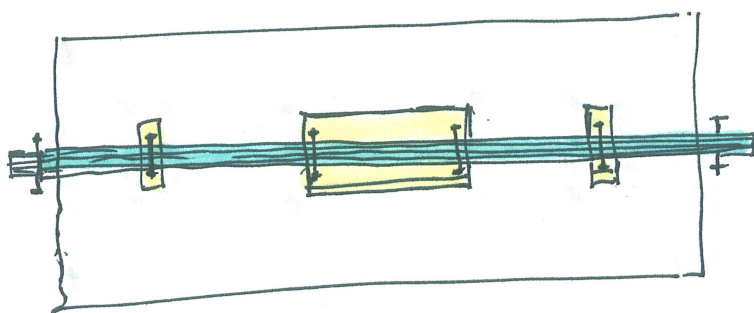

Continuous 5-span "viaduct" footbridge —

- extensive but repetitive structure
- maximum visitor experience.

The candidate needs to be bold enough to decide the level of the pedestrian access and whether stairs are permitted or a ramp needed. Again, options suggest themselves:

1. For the simple "beam-type" footbridge — a single span — a ramp at 1:20 can be formed leading from ground level up to the first platform level (+4.0m)

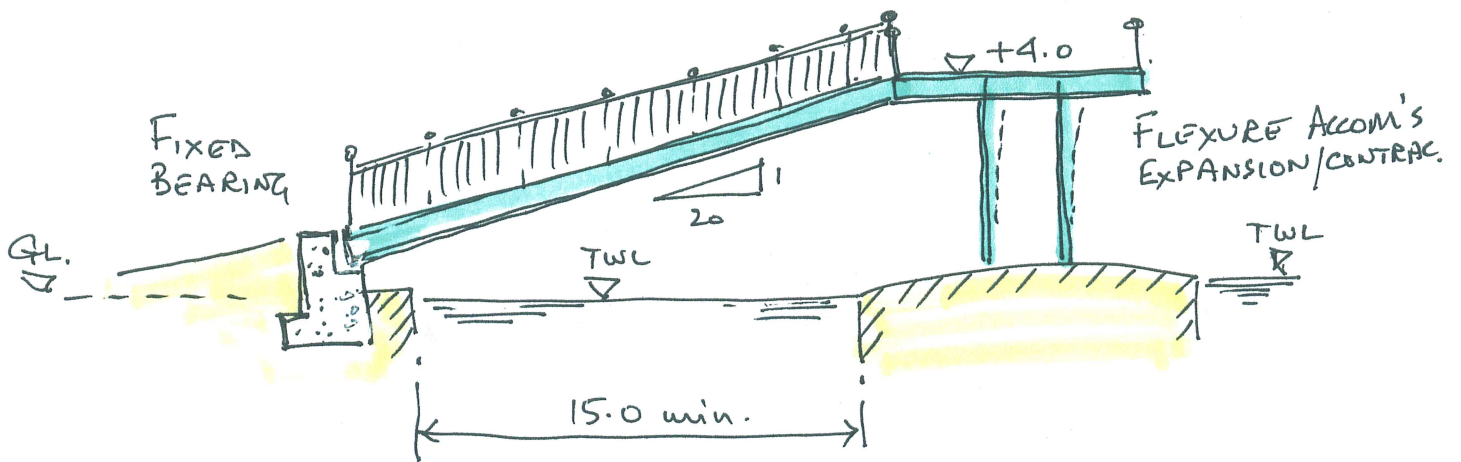

NOTE: the ramp incline of 1:20 is recommended in the CORUS publication "The design of Steel footbridges", and can be as steep as 1:12.

2. For the 4-span footbridge something that is more exciting is possible:

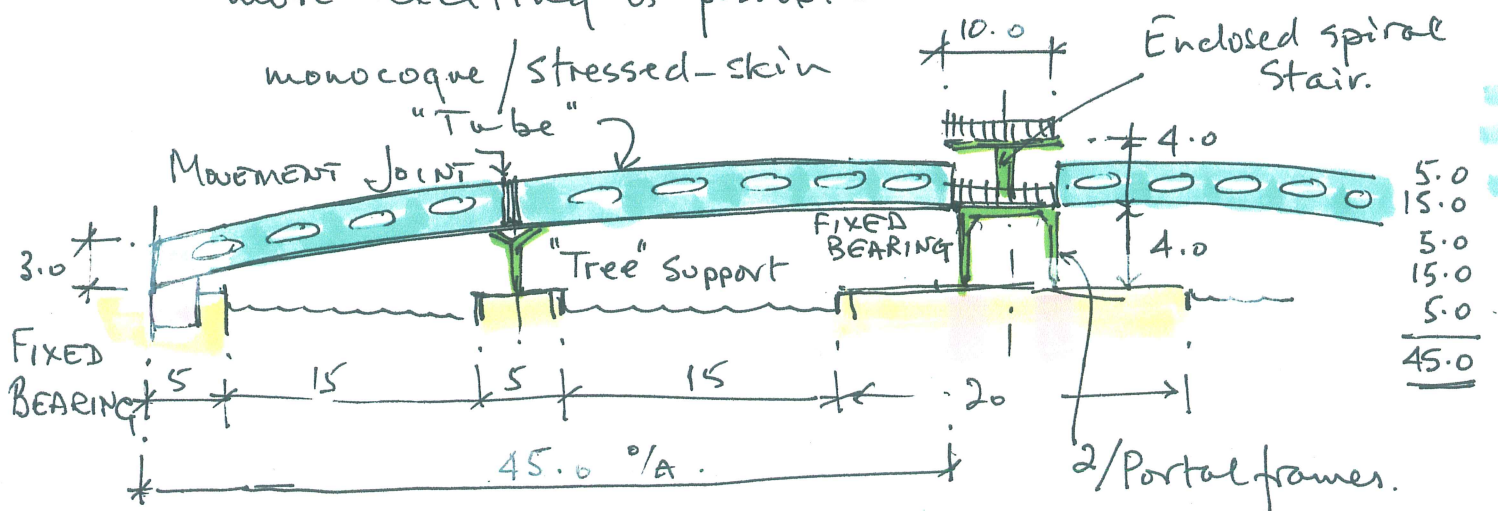

RAW  
2008

Here, the observation tower becomes a central support and climax. It needs to be considered in detail. In Option 1 on page 5 the "beam-type" bridge would benefit from the inclusion of the tower.

Both platforms must have an area of  $10m^2$  min, i.e.  $3.16 \times 3.16$ ; must have access between them [more than a mere ladder as it is for public use]; and may need roofs or canopies to shelter from rain or sun.

A spiral staircase would occupy the least space and allow intrepid viewers access to the top platform. The question requires a  $2.0m$  access = effective width of the stairs - this makes the drum  $(2 \times 2.0) + 0.5 \text{ say} = 4.5$  diameter.

It has been assumed that the platform area of  $10m^2$  is additional to access areas.

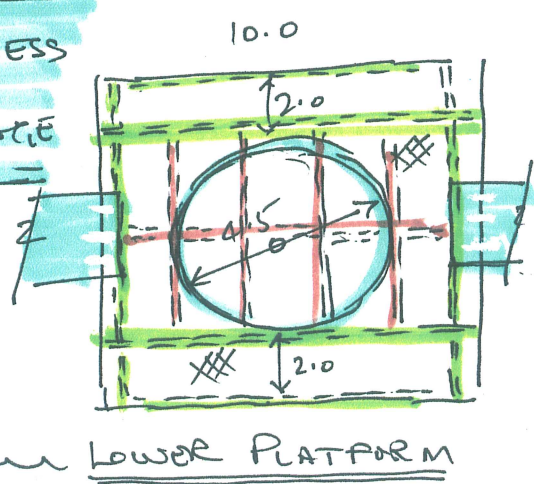
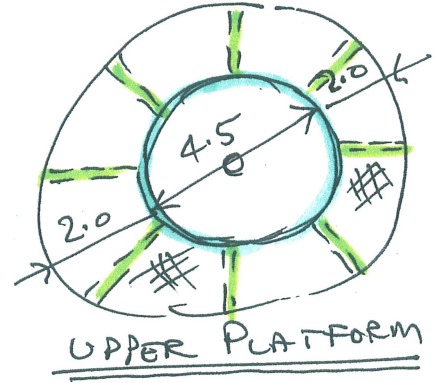
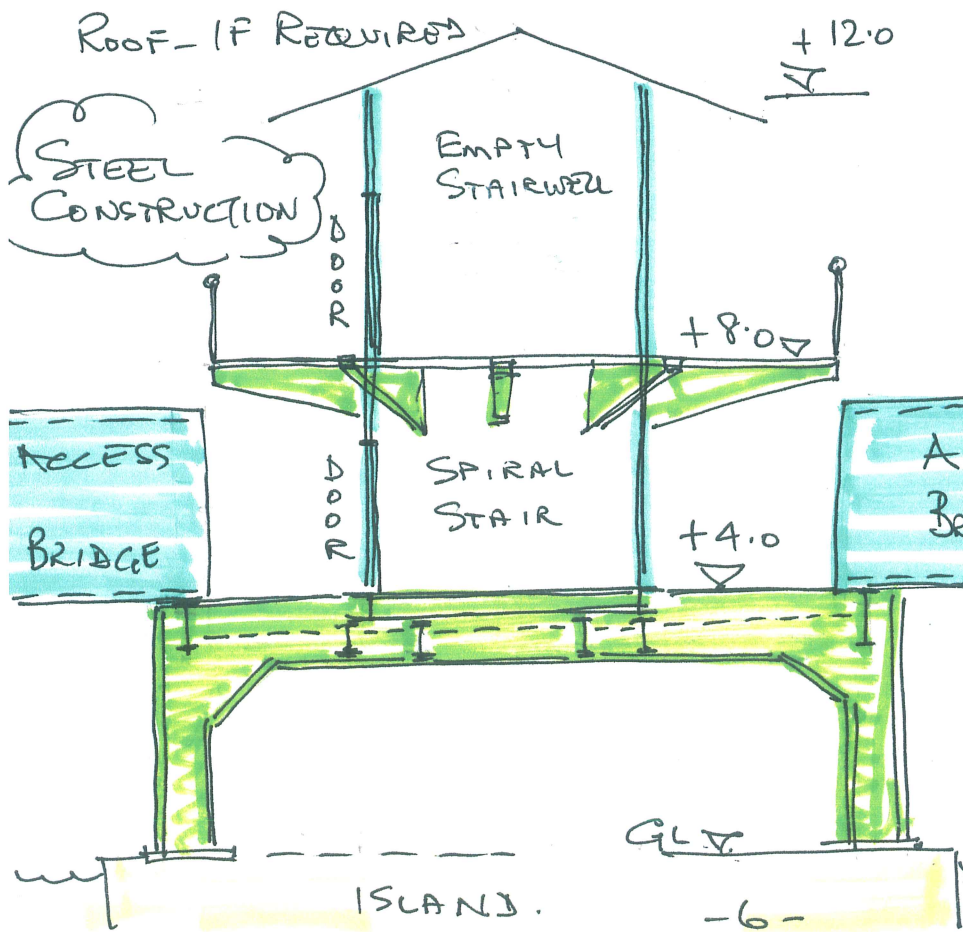

An alternative viewing platform would be square:

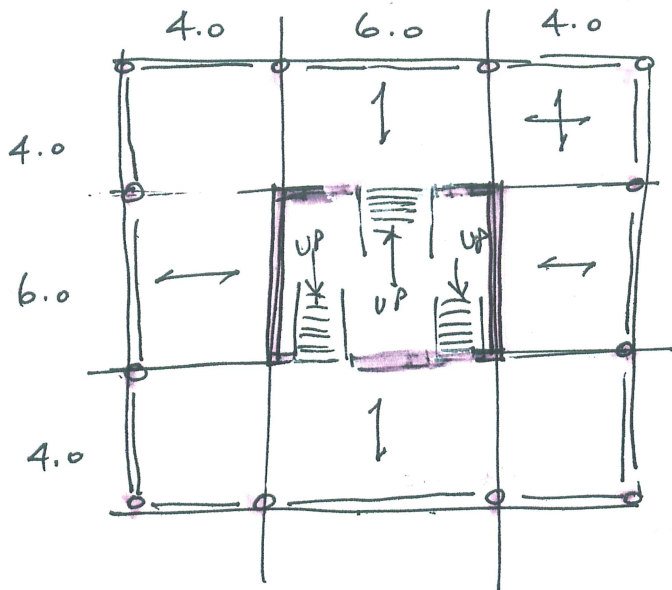

PLAN AT + 8.0m

PARAPET  
UPSTAND  
BEAMS

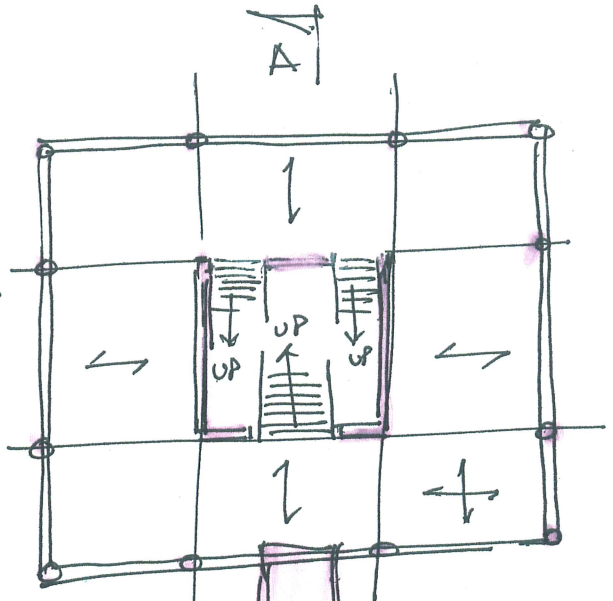

PLAN AT  
+ 4.0m

ACCESS  
BRIDGE

REINFORCED  
CONCRETE  
CONSTRUCTION.

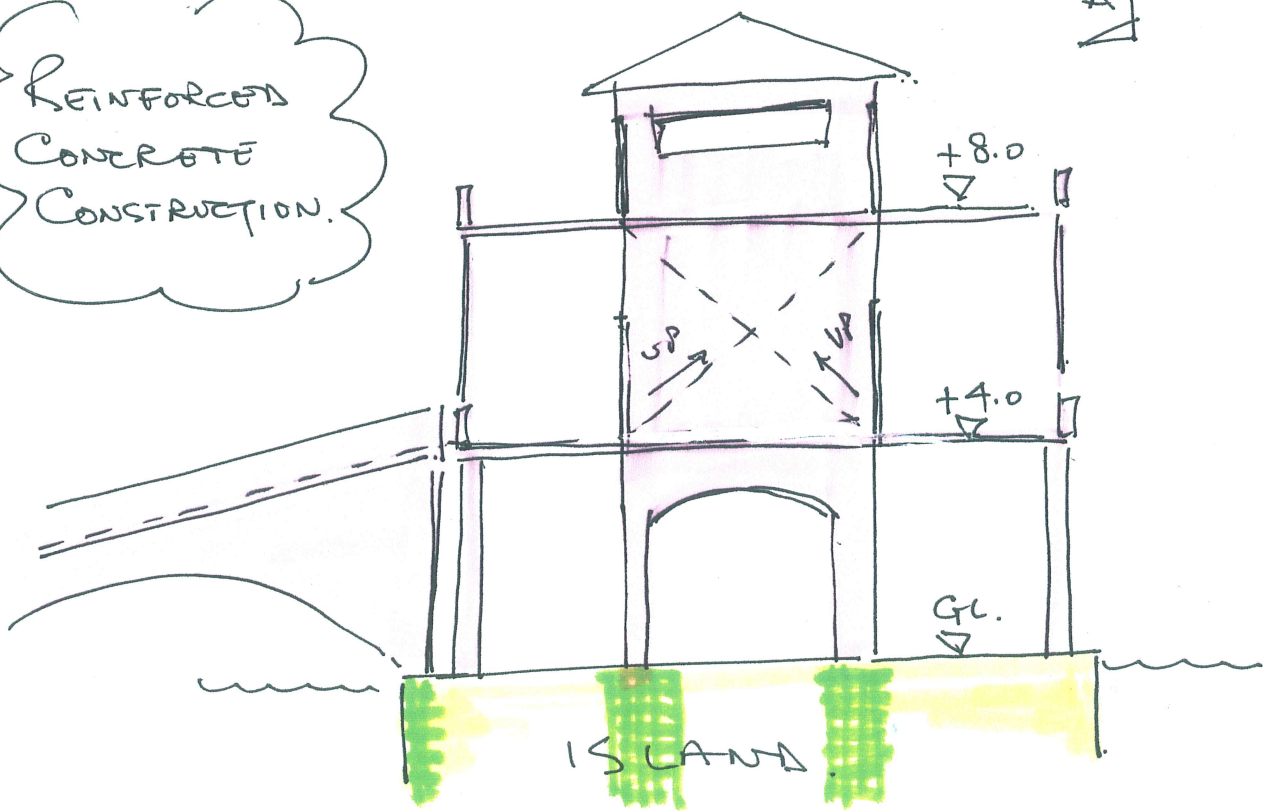

SECTION A-A

The respective cross-sections for the access footbridges are:

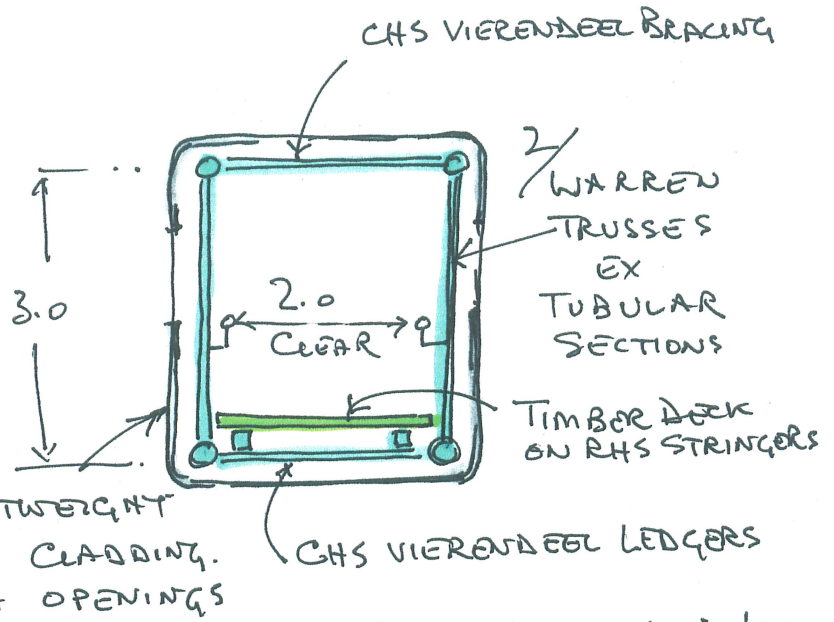
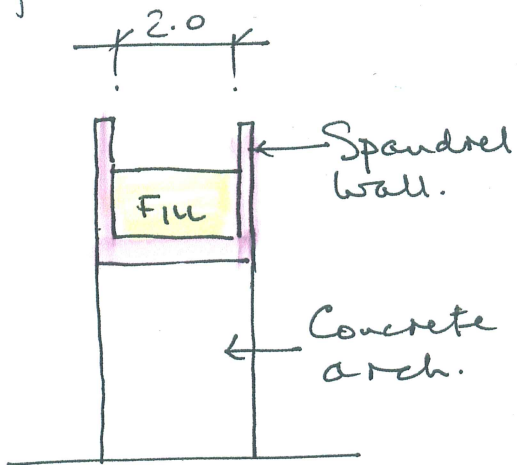

Note: The stressed skin concept is too complex for the time available - use more traditional construction.

Foundations:

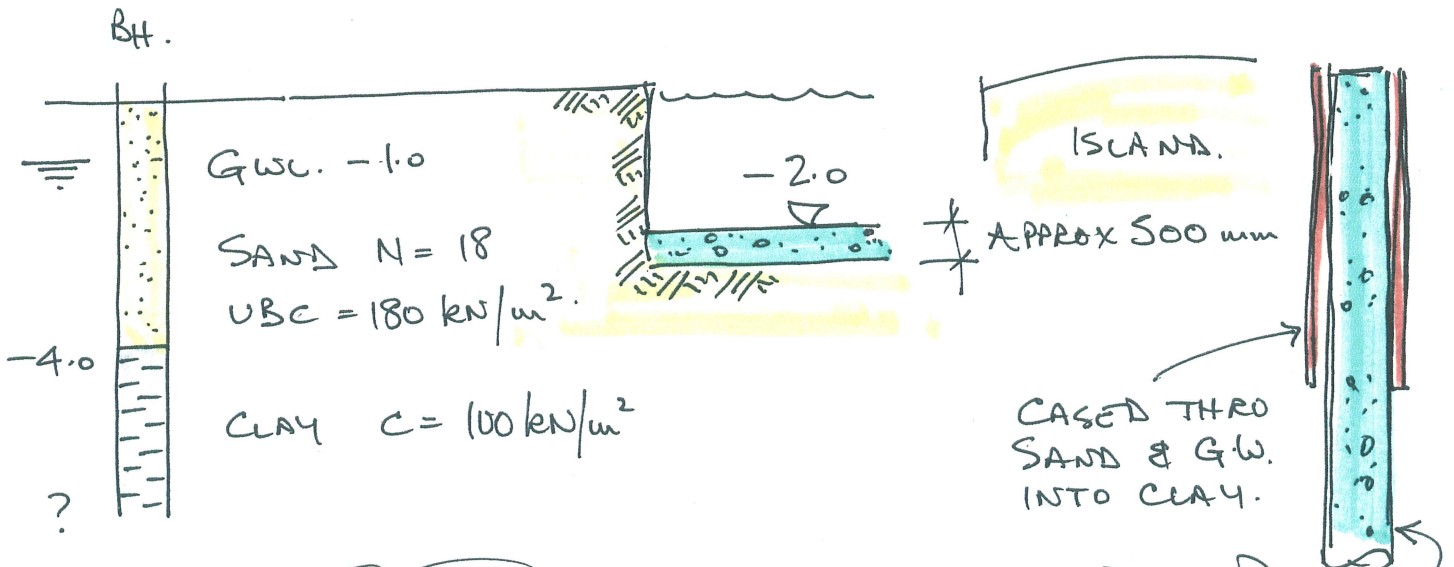

All piles set out and boxed before excavations  
 Positional tolerance  $\pm 75$ mm.

SMALL-DIAMETER BORED PILES  
 (Concrete replacement)  
 $\phi$  600 DIAMETER  
 (By definition)

The "Tree" support will require a fixing moment.  
 Provide a pile group and pile cap

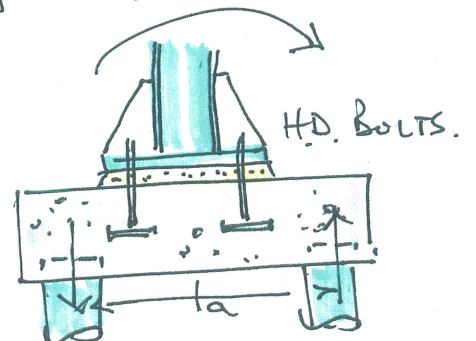

In SECTION 1a the question requires the candidate to "indicate clearly the functional framing, load transfer and stability aspects OF EACH SCHEME."

Consider the number of marks that may be available: Section 1a is worth 40 marks to cover two, equally developed options — i.e. 20 marks per option. Of these marks, 12 may go to the option and its sketches, 5 may go to the "framing, load transfer and stability", and the remaining 3 marks to the reasoning behind your choice of solution. 25% of an option's marks will not be awarded to a bland, generalised answer: it is important that you apply your general knowledge to the specific problems of the Option.

\* If your options are truly distinct and different so will be the functional framing, load paths and stability aspects!

Let Option 1 be a circular tank. The prime behaviour is hoop tension. The tension is entirely resisted by circumferential reinforcement, the concrete forming the water-retaining "membrane" but cracking through-and-through. By limiting the crack width to 0.2mm (See BS 8007) leakage can be reduced to a minimum.

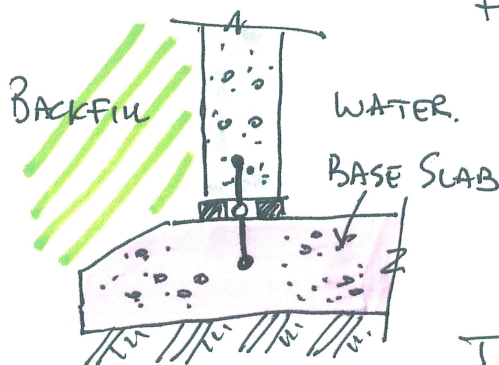
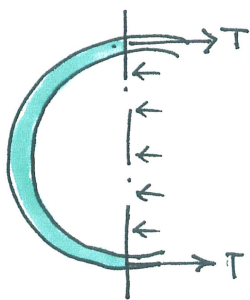

Abnormally, the drum will be backfilled before filling the tank with water. The drum will compress and tend to move inwards. The joint at the base of the wall will allow this to happen.

The wall is built as a series of rings with horizontal construction joints and is intrinsically stable.

Let Option 2 be a rectangular tank. The prime behaviour of the perimeter retaining wall is cantilever action, though for low-height walls the mass-gravity principle would be more economical:

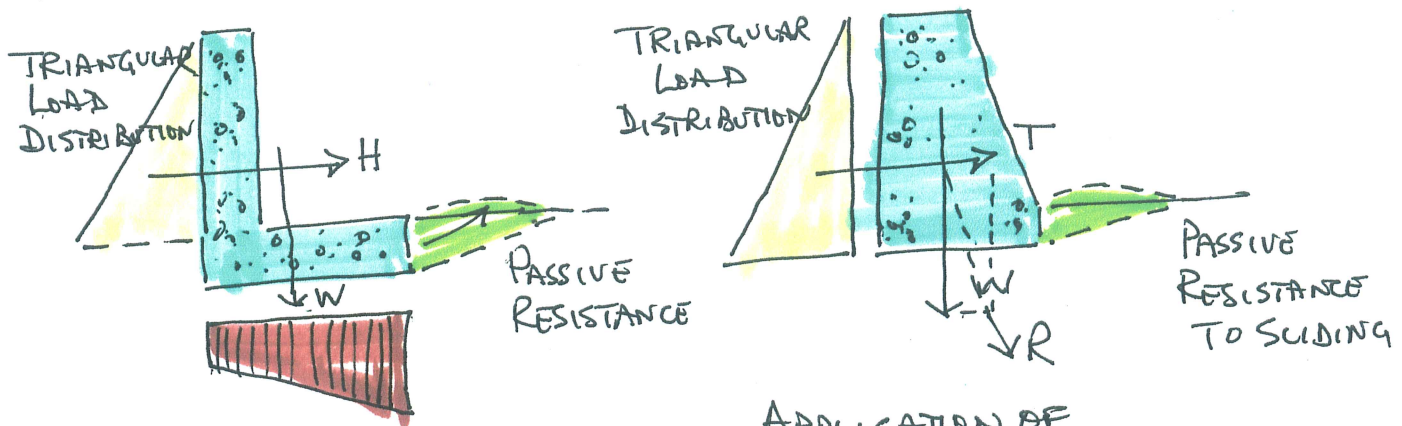

PRESSURE DISTRIBUTION UNDER BASE

APPLICATION OF MIDDLE-THIRD RULE. - RESULTANT CUTS BASE  $\times$  B/6 FROM CENTRELINE OF BASE

The floor slabs can be used to provide the "passive resistance" required to prevent the wall from sliding forward. Waterstops would be incorporated between lengths of wall and along the toe/floor-slab joint.

Let Option 3 be the simple "beam-type" footbridge.

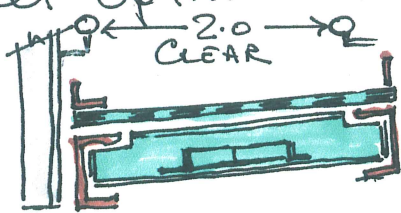

← 6mm Deck plate with Flat or EA attached along both edges, structurally participates with the pair of steel beams.

$L/H = 30$  Try 700 x 250 fabricated channel ex 15mm thk plt or alternatively 762 x 267 UB. Fit tie beams at 4.0m  $\%$  with each bay X-braced using 60 x 60 EA. Standard beam behaviour with fixed bearing at foot of ramp. Note that bank seat is raised above G.L. to accommodate the downstand of the stringers. Movement absorbed by flexure in the observation tower's supports. Fabricate as single unit to be lifted into place by crane. The resulting temporary stress reversal to be checked for compliance.

Let Option 4 be the "viaduct" footbridge:

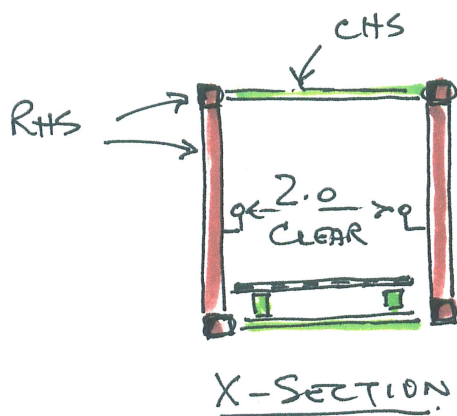
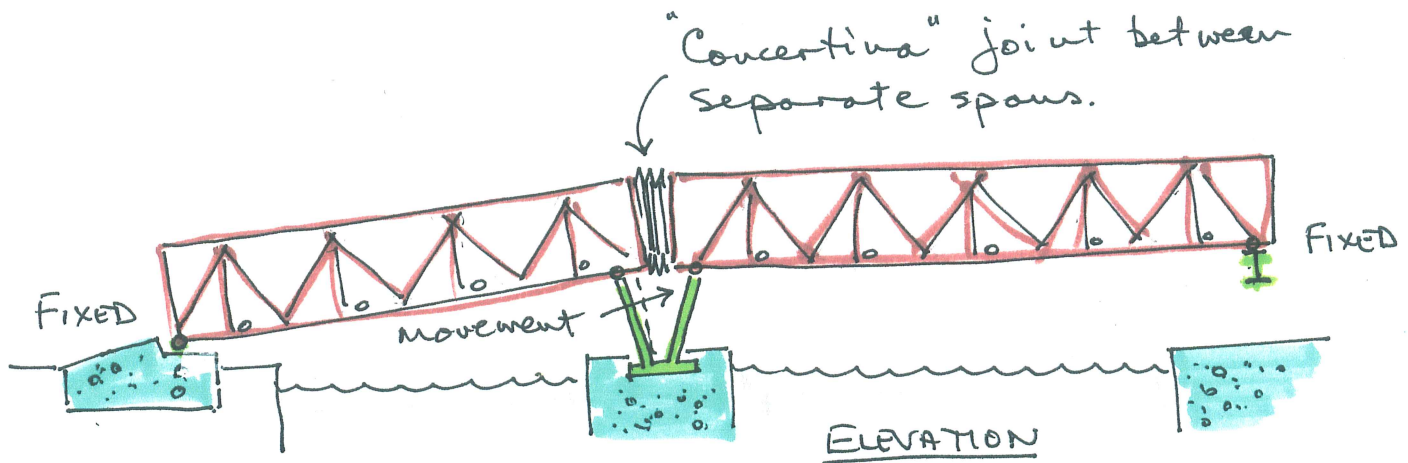

Modified Warren trusses ex. RHS. with tubular ties and ledgers.

Floor load transferred through longitudinal RHS to transverse ledgers, thence to nodes of the two main trusses.

The end bearings are "fixed" and movement is accommodated at the "Tree" support and a "concertina" joint in the cladding. The bank seat is sunk into G.L. because main structure is upstanding. The "fixed" support between the portal frames supporting the observation tower comprises an Universal Column section — for lateral stability. Cladding will be attached to all four surfaces of the "through-type" footbridges. Wind loads will be transferred into the top and bottom wind trusses formed by the tubular ties and ledgers [with X-bracing] or in rierendeel manner [without X-bracing]

The "Tree" support comprises four inclined tubular legs springing from a base plate. Longitudinally-acting hinge bearings hold the trusses in position, while allowing flexure and longitudinal movement.



Let Option 5 be a portal-frame-supported observation tower!

The observation tower comprises a +4.0m-level platform 10.0 x 8.5 with a central spiral stair leading to the +8.0m-level upper platform 8.5m diameter. A roof may be added if required — See page 6.

The upper platform is made of 8mm. plate [with non-slip resin surface finish] supported off the circular shaft on cantilever brackets. The ends of the cantilevers support the parapet. A ring beam provides torsional restraint.

The circular shaft is made of steel plate with appropriate protective coatings inside and outside. The "drom" is bolted to a ring beam that is in turn bolted/welded to a grillage of rolled steel sections supported between a pair of fabricated (welded) plate portal frames with fixed bases. The proportions of the frames make them very stiff — see page 6.

The grillage will resist the uplift caused by the wind-moment on the "drom". There will be a corresponding downward force on the opposite side of the "drom".



The grillage (see page 6) will have a critical loading related to wind blowing down the length of the tank.

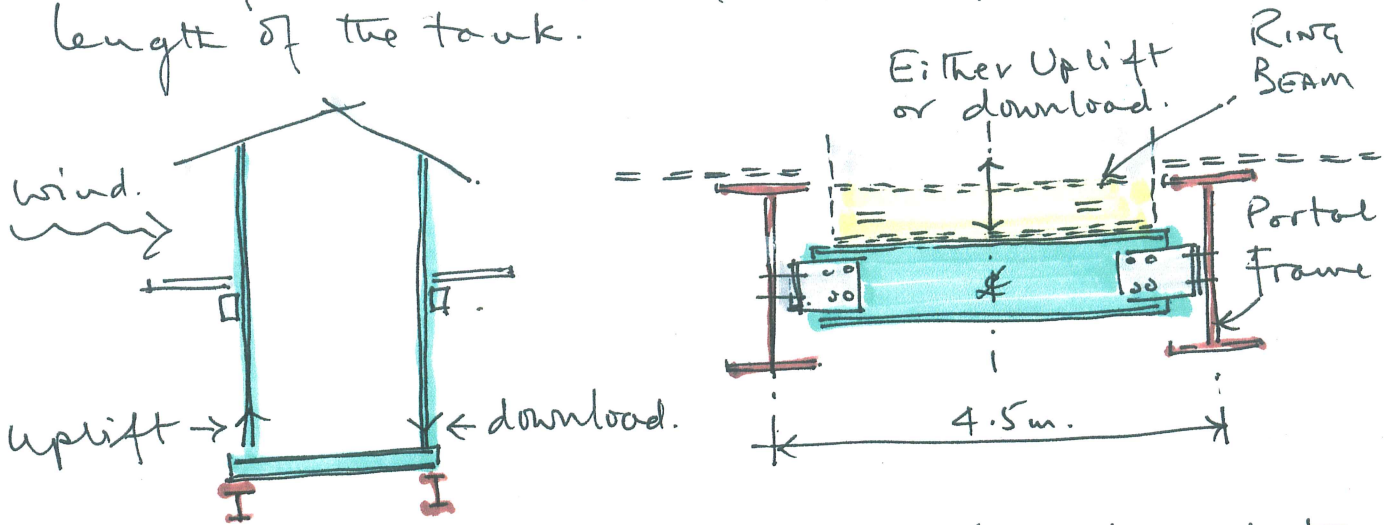

There will be some load-sharing through-out the grid but this will require detailed analysis.

The portal frame (see page 6) will collect loading from the footbridges, the spiral staircase, and the cantilevered side-platforms.

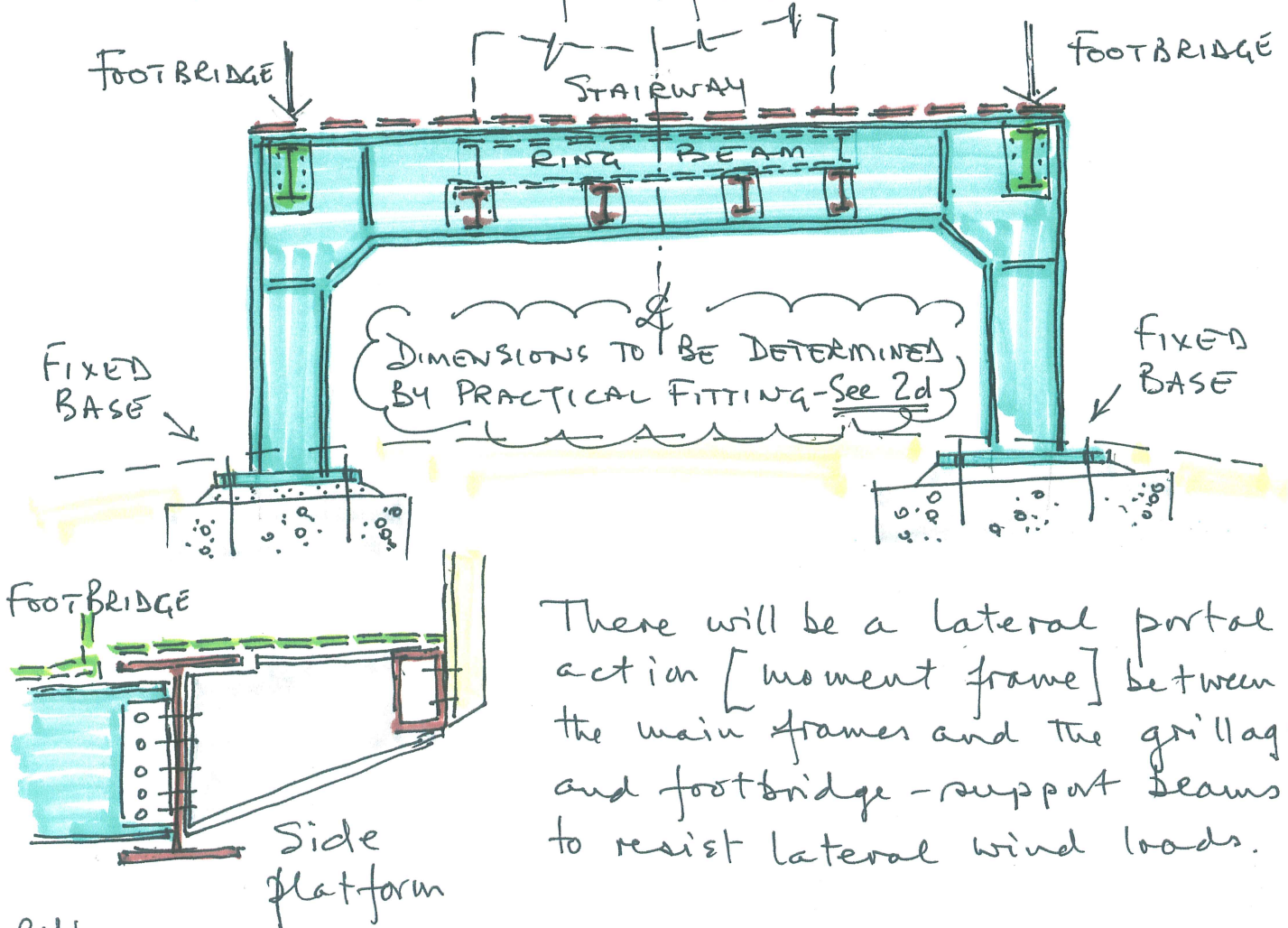

There will be a lateral portal action [moment frame] between the main frames and the grillage and footbridge-support beams to resist lateral wind loads.

RAW  
2008

Let Option G be a reinforced-concrete, column-supported staircase tower and verandah slabs, see page 7. There are two decks: at + 4.0m and + 8.0m. These span 4.0m one-way except at the corners where the square panel spans two-ways. The slabs are underslung from the parapet upstands and supported on perimeter columns. The staircase walls support the inner edges of the slabs. Between ground level [GL] and + 4.0m level the staircase walls give way to four columns with arched beams [mainly for appearance]. The outer or perimeter columns are supported off a ring beam on piles. The inner columns would stand on a raft-like pilecap. These proposals may be changed if it is found to be more economical to have a 14m x 14m, island-sized slab base on a pile group.

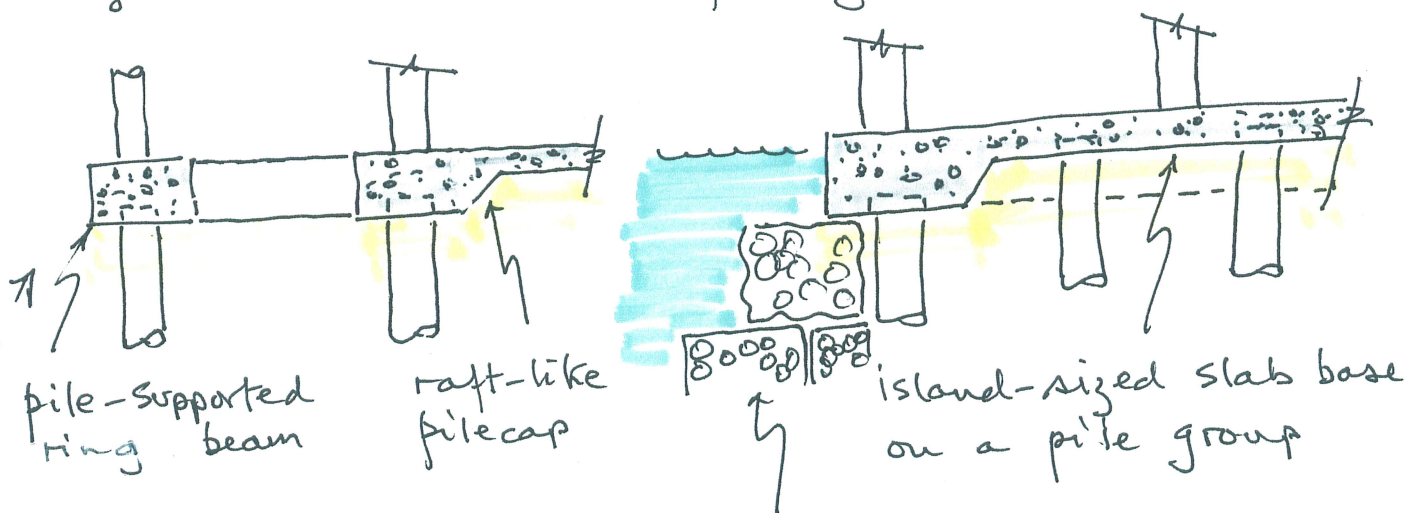

Ditto this proposal.

Cgabion surrounds to the island core.

The wind loads will be absorbed by the staircase "core", the upper walls [pierced by doorways and windows] acting like shear walls and focusing the loads onto the four columns below level 4.0m. With the concrete construction uplift is unlikely. The access ramp has its own, separate support on the edge of the island and shares the piled foundations with the perimeter columns.

My final, recommended scheme brings together the 40.0m x 90.0m tank, the 4-span footbridge and spiral-staircase observation tower. The tank will be constructed by the "partial excavation" method - see page 2.

I give the following reasons for making this choice:

- The overall scheme provides the best visitor experience with greatest access safety.
- Flotation of the tank will not occur unless there is a substantial rise in ground-water level such as might happen in a flood. The question does not require us to propose inlet and outlet works, etc.
- The construction chosen allows the building of the low, mass-concrete retaining walls at ground level and the piling [from a working platform at ground level] and the pilecaps and ground beams to proceed simultaneously. The steelwork fabrication can also be started.

Delivery and erection of the steelwork is made before the adjacent excavations are started. Excavation can be made as soon as a suitable length of retaining wall is completed. Concreting of the tank's base slabs can be done in sections.

- Because of the symmetry of the scheme one half may be completed, stocked and opened to the public. Appropriate division walls and safety measures will be necessary.

---

THE ANSWER TO SECTION 1A IS SYSTEMATICALLY DEVELOPED FROM "REQUIREMENTS" TO "IDEAS" THAT

COVER THESE REQUIREMENTS, TO THE "DEVELOPMENT" OF THE "FUNCTIONAL FRAMING" AND A DEMONSTRATION THAT THE LOADS ARE "PROPERLY TRANSFERRED" AND THAT THE WHOLE SCHEME IS "STABLE"

\* THIS WORK MUST BE DONE WITH EQUAL DILIGENCE FOR BOTH SCHEMES. \*

FROM THIS DETAILED BACKGROUND THE CHOICE OF SCHEME WILL EMERGE AND NEEDS TO BE STATED AND EXPLAINED. THE QUESTION REQUIRES YOU TO "IDENTIFY THE SOLUTION YOU RECOMMEND, GIVING REASONS FOR YOUR CHOICE".

YOU DO NOT NEED TO PREPARE A DETAILED COMPARISON OF THE TWO SCHEMES.

---

SECTION 1b - the following notes would be composed into a letter to the Client.

- Although it is quite probable that the grade of concrete used will be the same for walls and base slabs, it is unlikely that they will be in the same cast. The information indicates that this is an ongoing problem over a period of time.
- It is most unlikely that the Client will be involved at the first cube "failure". This confirms that a problem with the concrete production has been experienced for some time.
- The problem appears to be confined to the "production" of the concrete - a time when cubes or cores provide the quality control information - i.e. "test results".
- The indications are that one or more of the material constituents are the cause of the low strength.

#### ■ Considering the cement:

- if supplied and stored in bags the cement may be "air set" or partially hydrated.
- the batching of the cement may not be accurate. Only "full-bag" batching is acceptable. Even with bulk storage in a silo, the weighed cement may be partially blown away by the wind when it is transferred to the mixer.

#### ■ Considering the aggregate:

- fine sand or sand with a high silt content will have a high water demand and the water-cement ratio will be altered. The water-cement ratio should be about 0.45: there will be a loss of strength if this rises to 0.6 or more.
- fluvi-glacial deposits are quarried, washed and graded. The gravel-sizes, in particular have many varied origins. Within my experience one component of a gravel aggregate was "vein quartz" where the quartz had formed from the sides of the fissure but not altogether joined down the middle. In consequence these nodules had a substantial void in the middle into which the cement paste flowed — leaving too little mortar for binding the gravel aggregate. Initially, greater and greater cement quantities were used but became uneconomic. The matter was resolved by crushing the voided gravel and increasing the original cement quantity because of the resulting smaller aggregate.

The Client needs to know about the situation, and that the matter is under control. The investigations are ongoing but may take a little time, and in the meantime concrete work will be suspended. This may result in a delay to the programme. Depending upon the outcome of the investigations some contractual changes may be necessary — perhaps a new supplier for the cement or aggregate.

Concerning the completed work — This will be carefully examined both visually and with non-destructive testing techniques such as the impact hammer. However, it is not expected that any distinctive faulty areas will be found.

Consideration should be given to lining the tank with a waterproof cementitious mortar. Small faulty areas may be broken-out and recast.

---

THE LETTER SHOULD NOT BE ATTEMPTED WITHOUT PRELIMINARY NOTES AND SKETCHES. THERE ARE 10 MARKS AVAILABLE: EQUIVALENT OF 40 MINUTES WORK. THIS IS NOT AN OPPORTUNITY TO "MAKE-UP TIME"! IT IS, HOWEVER, AN OPPORTUNITY TO SHOW THAT YOU HAVE EXPERIENCE OF DEALING WITH PROBLEMS AND THAT YOU KNOW YOUR CONCRETE TECHNOLOGY. YOU ARE NOT ADEQUATELY PREPARED FOR THIS EXAM [AND THE RESPONSIBILITIES THAT WILL RESULT FROM YOUR PASSING] IF YOU LACK EXPERIENCE OR ARE LACKING IN A KNOWLEDGE OF THE REGULAR MATERIALS AND PROCESSES — CONCRETE, STEEL, WELDING AND CONNECTIONS. [REMEMBER! THE LOAD PATH ALWAYS PASSES THROUGH CONNECTIONS.]

THESE REMARKS ALSO APPLY TO THE "METHOD STATEMENT/PROGRAMME" IN SECTION 2e. ASK YOURSELF "WHAT ARE THE CONSEQUENCES OF MY DESIGN DECISIONS UPON THE SITE WORKS?"

- WHAT WILL HAPPEN IF THE G.W.L. IS NOT DRAWN DOWN?
- WHY HAVE I ASKED FOR A FIXED BEARING AT THE BOTTOM OF THE RAMP?
- CAN THE ASSEMBLED BRIDGE BE LIFTED INTO PLACE? ETC!

- IT IS MOST IMPORTANT TO SHOW THAT THE PILING MUST BE INSTALLED BEFORE A LARGE HOLE [ AND CONSEQUENTIAL PLANT ACCESS DIFFICULTIES RESULT ] IS EXCAVATED — FORGET IDEAS OF LIFTING PILING RIGS AND EXCAVATORS DOWN INTO BASEMENTS AND TANKS !
- STEELWORK TAKES TIME TO FABRICATE AND SPECIAL PLANNING IS NECESSARY BEFORE LONG SECTIONS CAN BE DELIVERED — THIS "LEAD-IN" TIME NEEDS TO BE SHOWN ON THE PROGRAMME
- THERE WILL ALWAYS BE A NUMBER OF ACTIVITIES ON THE "CRITICAL PATH". THE DESIGNER MUST BE AWARE OF THESE AND COMPLETE THE DESIGN AND DETAIL IN TIME TO PREVENT DELAYS BECAUSE OF "LACK OF INFORMATION".
- ETC!

\* ANTICIPATE YOUR ANSWER TO SECTION 2c WHILE YOU ARE DESCRIBING YOUR ALTERNATIVE SCHEMES — THE ERECTION METHOD [E.G. PROVISION OF SPACES] OR THE PROGRAMME [E.G. GROUND WORKS] MAY INFLUENCE YOUR SELECTION AT THE END OF SECTION 1a ! \*

Section 2c requires, "Prepare sufficient design calculations to establish the form and size of all the principal structural elements including the Foundations." Section 2d follows with the necessary drawings. Keep these two separate for the purposes of the examination: however, you may find it convenient to work on them simultaneously. It may be convenient to draw until you find that you need some design information, make the necessary calculation and proceed with the drawing. Many sizes and details, at this stage, are arrived at [with sufficient



accuracy] from good, sound experience [BUT SEE THE NOTE ON PAGE 18].

HOWEVER, the following items may need a calculation or two [depending upon your work experience]:

- Crack-control reinforcement when you design using BS 8007. These calculations will require assumptions about the cement content of the mix, the type of formwork, the section thickness and the type of aggregate. The crack-control reinforcement will often be sufficient to carry the loads applied to the finished structure. Do not try and bluff with a mention of BS 8007 as you will only expose your ignorance!
- The bearing capacity of the soils given in the question under "Ground Conditions".
- The Warren truss used for the footbridge. Note that the calculation will be for a regular Warren-type truss that will then be modified by adding the verticals that support the ledgers resting on the bottom chord [that would otherwise cause secondary bending in the bottom chords].
- The main portal frames under the Observation Tower. You may feel tempted to do "finished" calculations for the members comprising the grillage, etc, but these will take too much time. The basic portal frame will not be significantly altered if the point loads from the grillage reactions are a few kilonewtons over the precise value!
- Apply the wind loading in order to demonstrate your understanding of "stability". Consider the wind acting on the elevation of the Observation Tower - the loading on the weaker axis - and find the resistance necessary to prevent the tower falling over sideways.

One way of considering what may be regarded as "sufficient design calculations" is to imagine yourself as the project engineer in charge of a small team of less-experienced pupil engineers. What are the elements that need some design before you can delegate them? These will be the elements that you must design in Section 2c. All the rest of the routine calculations must, for economy, be done by the supporting team! [But eventually you will be responsible for checking that all the work has been done properly].

The same principle can be applied to Section 2d - the drawings and details, but with a modification: some of your design [see page 19] will be done on your drawing board - visiostatic proportioning - "if it looks right it probably is right!" This is not an invitation to take risks! You must have the experience before you can design by "proportion".

Another consideration, particularly when choosing which details you show, is the comparative importance of the information to the Quantity Surveyor. A routine connection detail is of comparatively little importance when compared to the detail of a complex welded/bolted connection like the one proposed at the knee of the portal frame [see p. 13] or the H-D bolts in the fixed base.

In this case the G.A Plan will need a very small scale in order to fit on a portion of an A3-sized page. It will only be able to show the leading

dimensions of the scheme - something like that shown at the top of page 2! Most of the information will be shown on cross-section details.

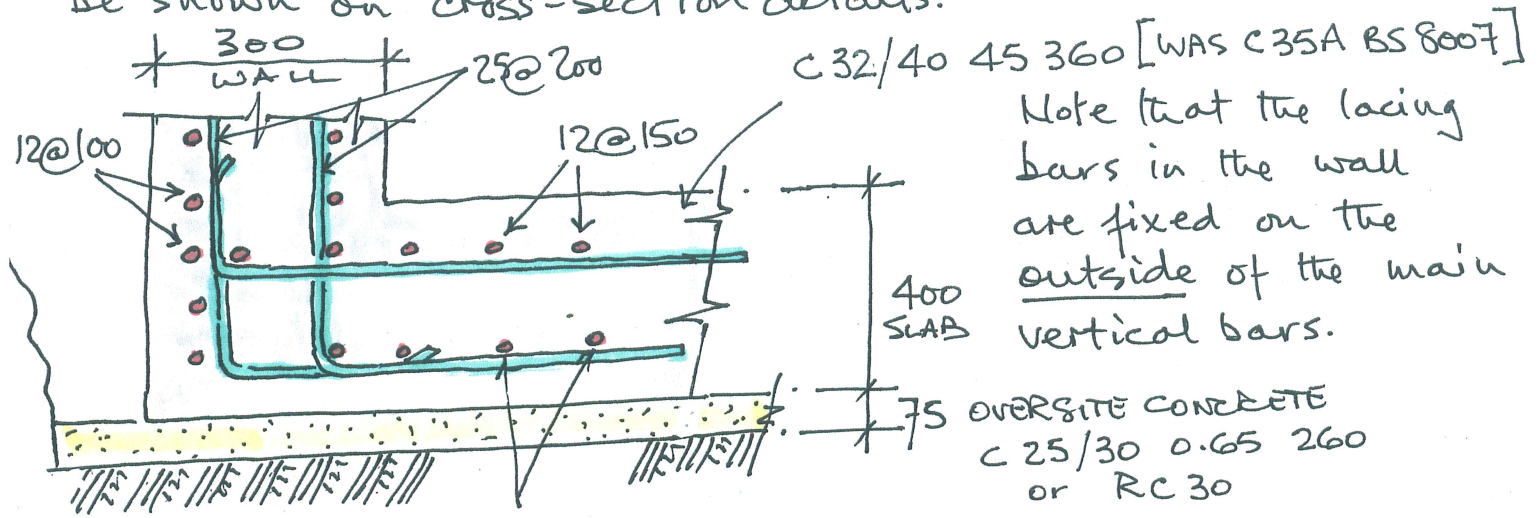

12@300

Additionally you will have to detail the joint positions and joint construction [reference BS 8007], and note whether you will allow "through-ties" for the wall formwork.

Other details might be:

• welded/bolted connection:

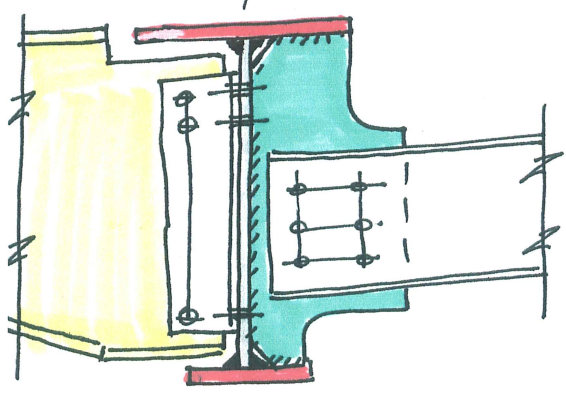

Asymmetrical flanges —  
 Web stiffeners —  
 Welding /////  
 Bolting ⊕

- The "tree" support and "concertina" joint
- Typical elevation and cross section of the Warren truss, with modifications.
- The island "containers" formed from gabions
- Typical cross section of the perimeter wall

YOU MAY THINK THAT THESE 22 PAGES ARE EXCESSIVELY LONG FOR AN ANSWER! HOWEVER, MOST CANDIDATES SUBMIT BETWEEN 20-30 A4-SIZED "SIDES" TOGETHER WITH 2-4 A3-SIZED "SIDES" AND INCLUDE COLOURED SKETCHES. THIS TAKES, TYPICALLY, 15 MINUTES PER SIDE AND SHOULD EARN 4 MARKS PER PAGE!

