

Chartered Membership Examination

Friday 13 April 2012

Structural Engineering Design and Practice

09.30 – 13.00 and 13.30 – 17.00 (Discussion between individuals is not permitted during lunch period). A period of fifteen minutes is provided for reading the question paper, immediately before the commencement of the examination. Candidates are not permitted to write in answer sheets, or on drawing paper or to use a calculator during this time. Candidates must satisfy the Examiners in ONE question.

Important

The written answer to the question selected and any A3 drawings must bear the candidate's number and the question number at the bottom of the page. Only the answer sheets supplied by the Institution may be used. The candidate's name should not appear anywhere in the script.

Notes to Candidates

1. TO PASS THE EXAMINATION, CANDIDATES MUST SATISFY THE EXAMINERS IN BOTH PARTS OF THE QUESTION ATTEMPTED.
2. Examiners will only mark work written by hand during the examination.
3. A fair proportion of marks will be awarded for the demonstration of an understanding of fundamental engineering concepts, as distinct from calculation of member forces and sizes. NOTE: In the calculation part of all questions, establishing "form and size" is taken to mean compliance with all relevant design criteria, i.e. bending, shear, deflection, etc.
4. In all questions 50 marks are allocated to Section 1 and 50 marks to Section 2.
5. The Examiners are looking for sound structural designs. It should also be remembered that aesthetics, economy and function are important in any competent engineering scheme.
6. Any assumptions made and the design data and criteria adopted must be stated.
7. Portable computers or programmable calculators may be used but sufficient calculations must be submitted to substantiate the design, and these should be set out as in practice.
8. Good clear drawings and sketches are required; they should show all salient and structural features to suitable scales and should incorporate adequate details.
9. Candidates will not be allowed to include any previously prepared calculations, notes, sketches, diagrams, computer output or other similar material in their answer sheets or A3 drawings. Any previously prepared information submitted by candidates will be ignored by the examiners.
10. Strictly no external electronic contact is allowed between a candidate and anyone outside the examination venue. Mobile phones must be switched off throughout the duration of the examination.
11. This paper is set in SI Units.

Now read 'Reminder' on page 3.

Chartered Membership Examination, a reminder from your Examiners

The work you are about to start has many features in common with other examinations which you have tackled successfully but it also has some which are unusual.

As in every examination you must follow carefully the NOTES FOR CANDIDATES set out for your guidance on the front cover of this paper; allocate the available time sensibly and set out your work in a logical and clear way.

The unusual requirement of the examination is that you demonstrate the validity of the training and experience that you have acquired in recent years. The Institution must be satisfied that you are able to bring all the various skills you are expected to possess to the effective solution of structural design problems – whether or not the problem is presented in terms that are within your actual experience.

Chartered Structural Engineers must have the ability to design and a facility to communicate their design intentions. Where you are required to list and discuss possible structural solutions you must show by brief, clear, logical and systematic presentation that you understand the general structural engineering principles involved.

In selecting and developing your design you should also remember the guidance given in the Institution's report, Aims of Structural Design, and in particular:

- (1) "the structure must be safe",
- (2) "a good design has certain typical features – simplicity, unity and necessity",
- (3) "the structure must fulfil its intended function".

If you have difficulty in deciding the correct interpretation of a question, pay particular attention to point 6. notes to candidates, on the front cover. The examiners will take into account your interpretation – and the design you base on this – if this is clearly stated at the beginning of your answer.

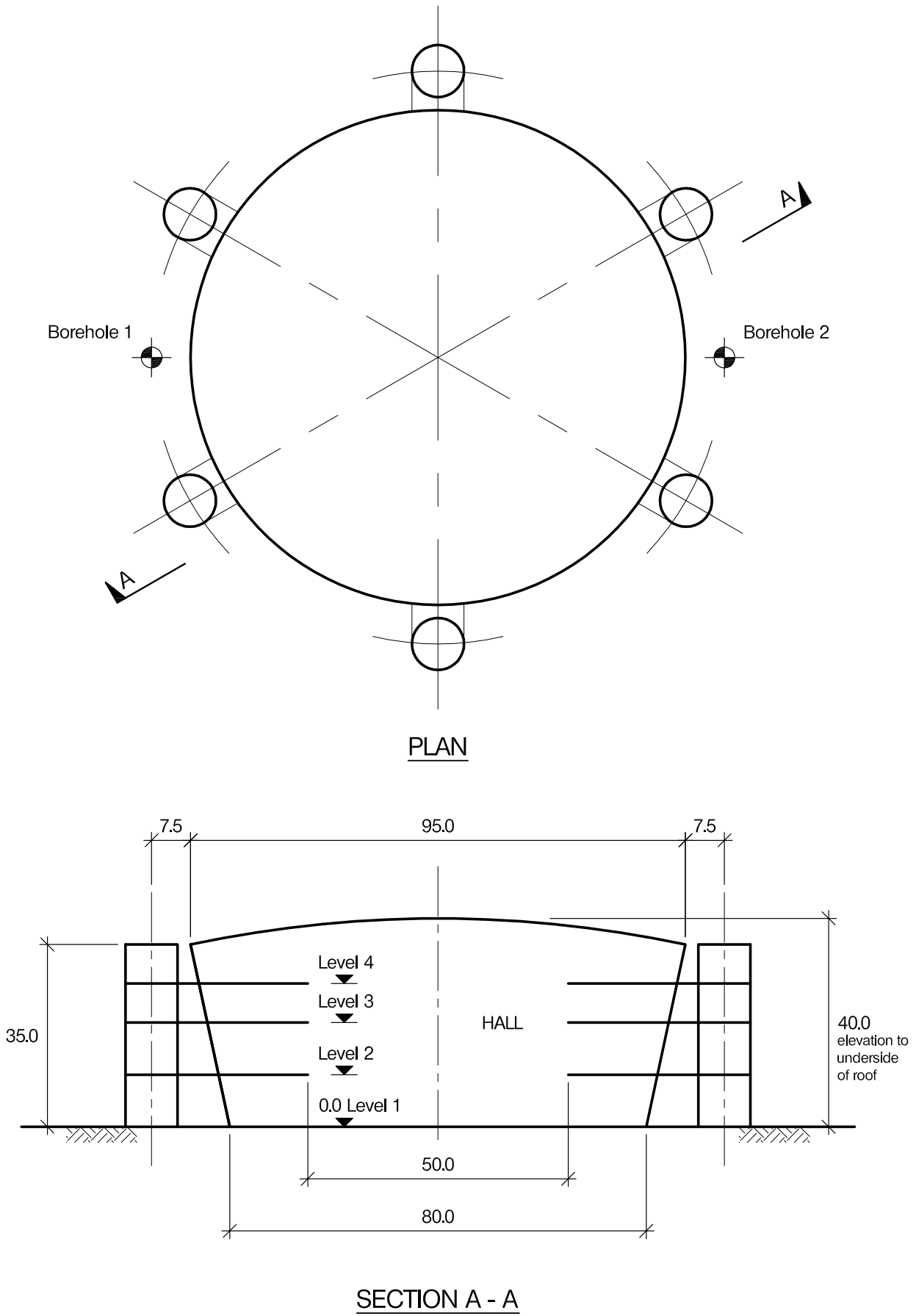

NOTE: All dimensions are in metres

FIGURE Q1

Question 1. Conference hall and exhibition galleries

Client's requirements

1. A circular conference hall and three floors of exhibition galleries is to be designed. It is accessed by six circular remote cores, each containing two lifts and a staircase which are joined to the main building by glazed link walkways. See Figure Q1.
2. The area at Level 1 is to be column free and only limited support is permitted to the floors at Level 2 and above. There is no restriction to the number of columns on the perimeter of the hall, except that they shall be at a minimum spacing of 8.0m at Level 1.
3. The client requires that 50% of the external wall surface between the access cores to be vertically glazed for natural lighting and the remainder to be clad with composite panels. The access cores are to be clad with composite panels.
4. The roof over the hall shall be of a lightweight structure with aesthetic consideration.
5. The respective floor to floor heights between Level 1 and Level 3 are to be 10.0m with a minimum clear height of 8.0m. The floor to floor height between Level 3 and Level 4 is to be 7.5m with a minimum clear height of 5.0m.

Imposed loading

- | | |
|------------------------|-----------------------|
| 6. Roof | 0.6kN/m ² |
| Floor Levels 2, 3, & 4 | 5.0kN/m ² |
| Floor Level 1 | 25.0kN/m ² |
- Loadings include an allowance for partitions, finishes, services and ceilings.

Site conditions

7. The site is level and located on the outskirts of a large city. Basic wind speed is 40m/s based on a 3 second gust; the equivalent mean hourly wind speed is 20m/s.
8. Ground conditions – Assume to vary linearly between boreholes.

Borehole 1	Ground level – 2.0m 2.0m – 7.0m Below 7.0m	Made ground Stiff clay, 100kN/m ² Rock, allowable bearing pressure 1000kN/m ²
Borehole 2	Ground level – 4.0m 4.0m – 9.0m Below 9.0m	Made ground Stiff clay, 100kN/m ² Rock, allowable bearing pressure 1000kN/m ²

Ground water was encountered at 2.0m below ground level.

Omit from consideration

9. Detail design of staircases and lift shafts, within the cores. The cores themselves are to be designed.

SECTION 1

(50 marks)

- a. Prepare a design appraisal with appropriate sketches indicating two distinct and viable solutions for the proposed structure. Indicate clearly the functional framing, load transfer and stability aspects of each scheme. Identify the solution you recommend, giving reasons for your choice. (40 marks)
- b. After the design has been completed the client advises that he wishes to hold a sports event in the conference hall and requires terrace seating at Level 2 and four television screens each weighing 5 tonnes hung from the edge of the floor at Level 4. Write a letter to the client outlining how this can be achieved and the implications. (10 Marks)

SECTION 2

(50marks)

For the solution recommended in Section 1(a)

- c. Prepare sufficient design calculations to establish the form and size of all the principal structural elements including the foundations. (20 marks)
- d. Prepare general arrangement plans, sections and elevations to show the dimensions, layout and disposition of the structural elements and critical details for estimating purposes. (20marks)
- e. Prepare a detailed method statement for the safe construction of the building and an outline construction programme. (10 marks)

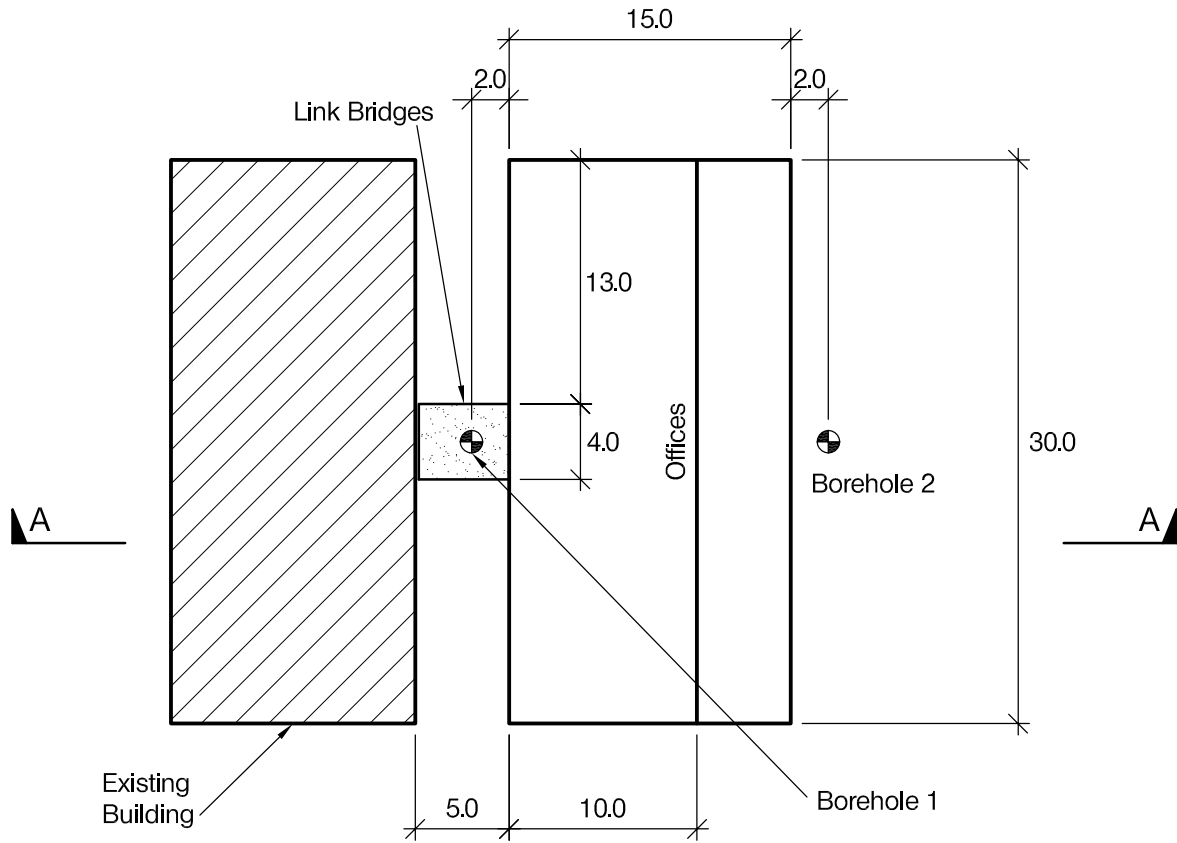

PLAN

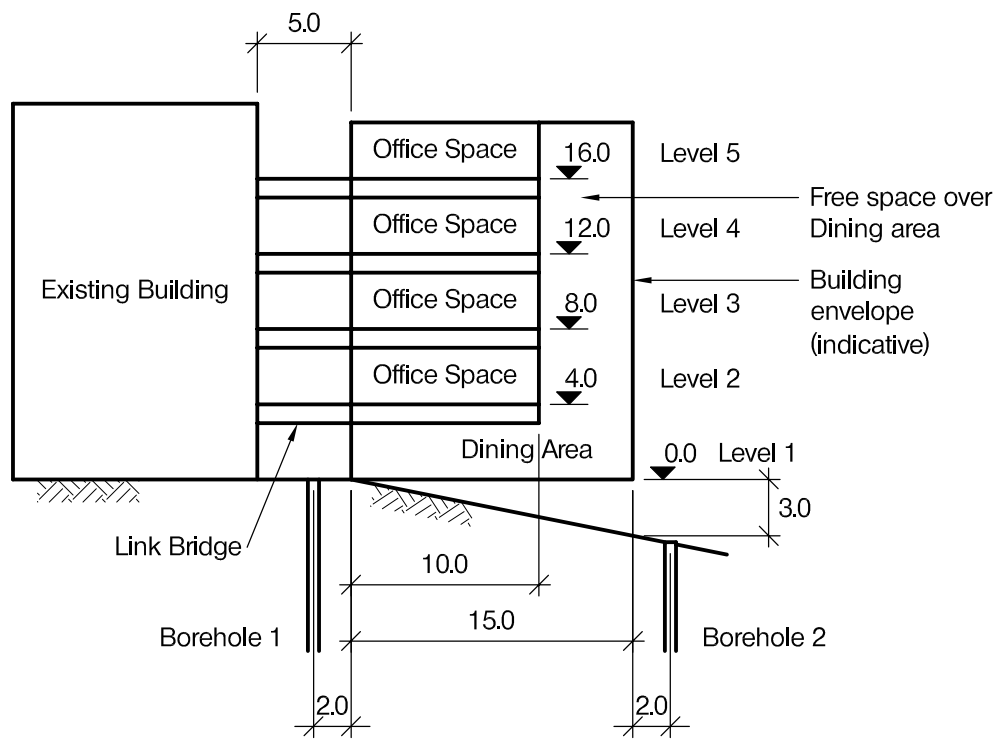

SECTION A-A

NOTE: All dimensions and levels are in metres

FIGURE Q2

Question 2. Headquarters extension

Client's requirements

1. An existing office building is to be extended to accommodate additional offices and a dining area. See Figure Q2. The exterior of the new building is to be clad with a patent glazing system that requires supports at 2.0m centres vertically and horizontally.
2. The dining area is to be 15m wide and 30m long. The clear height is to be 3m. Only two columns with a maximum size of 1m square are permitted in this area. No other structural members are permitted within this volume or in the free space above the dining area.
3. The office areas are to be 10m wide and 30m long. The clear height is to be 3m. No columns or other structural members are permitted inside the office areas.
4. The building is to be linked by pedestrian bridges at each floor level. No horizontal loads are allowed to be transmitted to the existing building via the bridges. To meet fire regulations, non-structural external stairs will be used.
5. There are no restrictions on the structure outside the building envelope. No bracing or walls are permitted inside the office spaces or within the dining area.

Imposed loading

- | | |
|-----------------|----------------------|
| 6. Roof loading | 0.5kN/m ² |
| Floor loading | 5.0kN/m ² |
| Bridge loading | 5.0kN/m ² |

Site conditions

7. The site is located in a coastal location. Basic wind speed is 46m/s based on a 3 second gust; the equivalent mean hourly wind speed is 23m/s.
8. Ground conditions:

Borehole 1 at Level 1	0.0m – 0.5m	Top soil
	0.5m – 2.0m	Sand, N=10
	2.0m – 5.0m	Gravel, N=30
	Below 5.0m	Rock, allowable bearing pressure 500 kN/m ²
Borehole 2 at 3m below Level 1	3.0m – 4.0m	Loose clayey sand
	4.0m – 7.0m	Gravel, N=30
	Below 7.0m	Rock, allowable bearing pressure 500 kN/m ²

Ground water was found at 4m depth from ground level.

Omit from consideration

9. Detailed design of link bridges and external stairs.

SECTION 1

(50 marks)

- a. Prepare a design appraisal with appropriate sketches indicating two distinct and viable solutions for the proposed structure. Indicate clearly the functional framing, load transfer and stability aspects of each scheme. Identify the solution you recommend, giving reasons for your choice. (40 marks)
- b. After your design is complete but before construction has been started, the client requests that the existing building be supported laterally by the new building. Write a letter to the client advising on the impacts of this decision on the new building. (10 marks)

SECTION 2

(50 marks)

For the solution recommended in Section 1(a):

- c. Prepare sufficient design calculations to establish the form and size of all the principal structural elements including the foundations. (20 marks)
- d. Prepare general arrangement plans, sections and elevations to show the dimensions, layout and disposition of the structural elements and critical details for estimating purposes. (20 marks)
- e. Prepare a detailed method statement for the safe construction of the building and an outline construction programme. (10 marks)

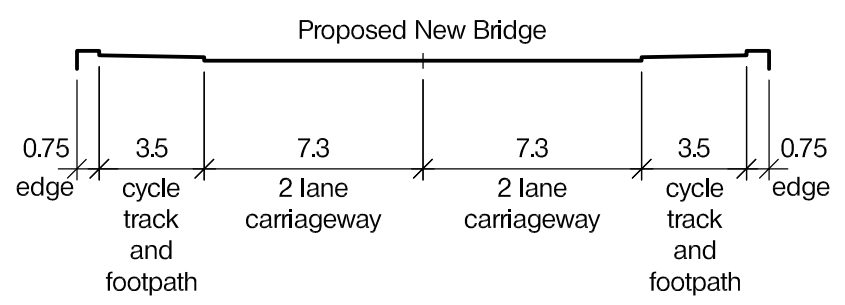
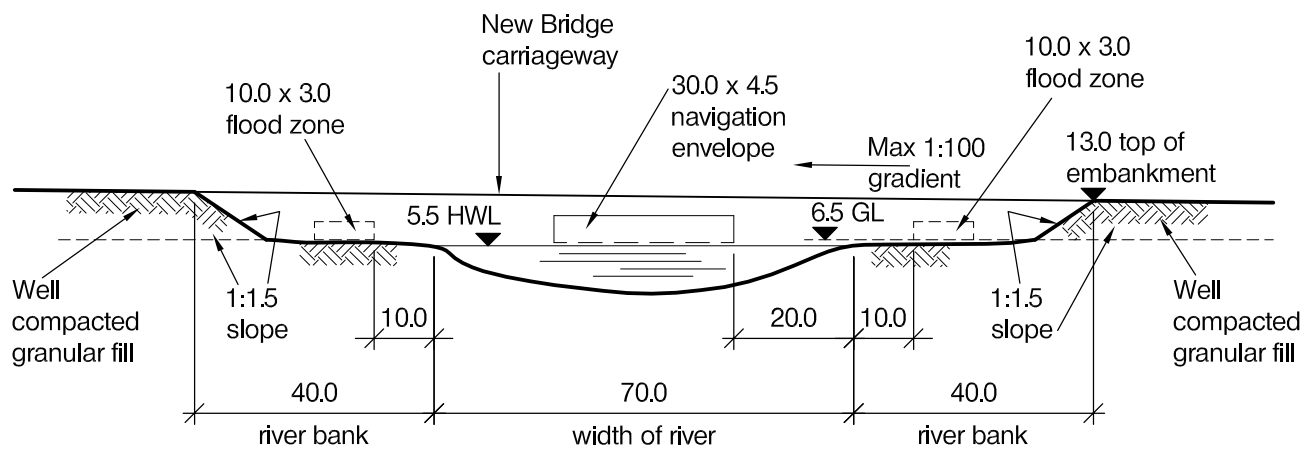
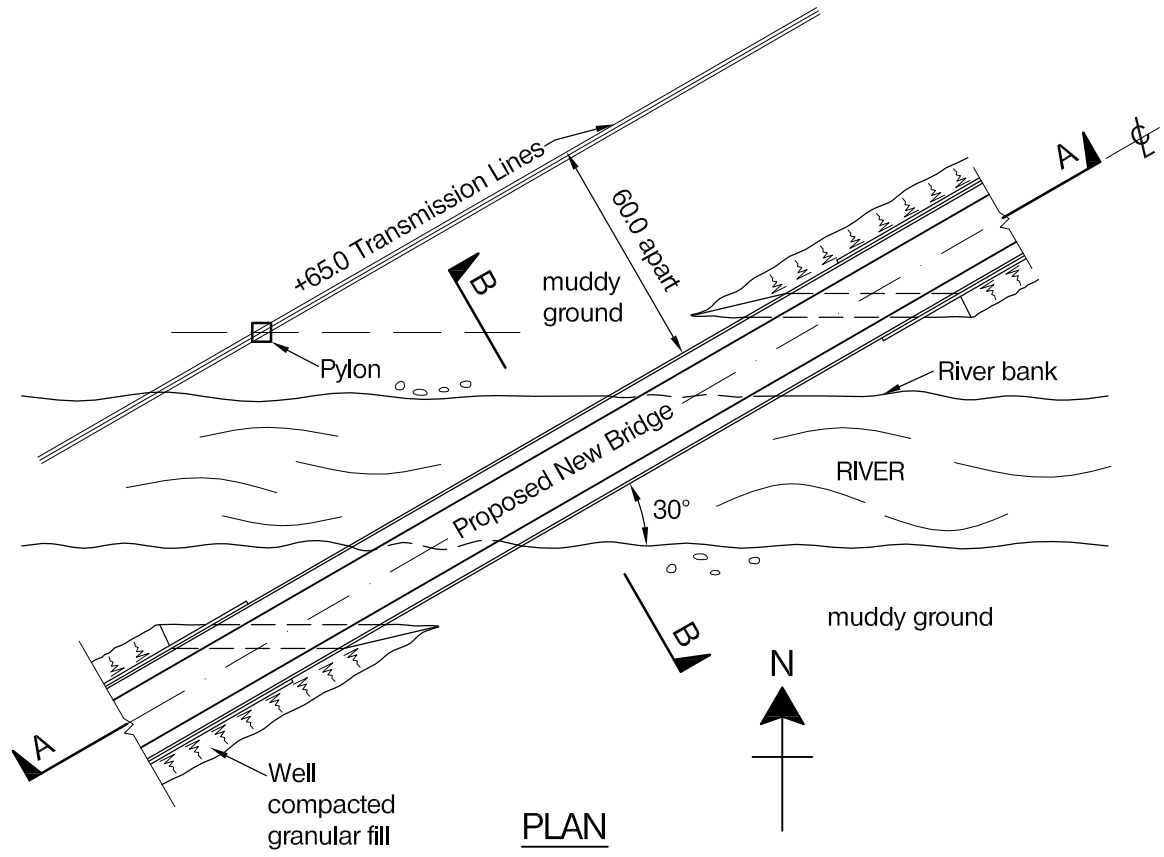

NOTE: All dimensions and levels are in metres

FIGURE Q3

Question 3. Road bridge over river

Client's requirements

1. A new bridge carrying a dual two-lane carriageway with a combined cycle track/footpath on each side is to be constructed over a river in the countryside. See Figure Q3.
2. Earth embankments for the new bridge on both sides of the river were constructed some years ago, so the fill material and ground below has been well consolidated.
3. A navigation clearance 30.0m wide x 4.5m high and two flood zones 10.0m wide x 3.0m high must be maintained at all times. No permanent structure including foundations is permitted within the river or the flood zones; however temporary works are allowed within the flood zones during construction.
4. The marine traffic in the river can be temporarily suspended for up to 3 hours after midnight from Monday to Friday for a period of two weeks.
5. The longitudinal gradient of the bridge shall not exceed 1:100. Vehicular parapets are to be provided. Existing high voltage electricity transmission lines at a level of +65.0m run parallel to the alignment of the bridge at a distance of 60.0m.

Imposed loading

6. Vertical traffic loading 10.0kN/m²
Footpath/cycle track loading 5.0kN/m²
Horizontal traffic loading 1500kN applied parallel to the carriageway across the full width of the bridge deck.

Site conditions

7. The site is located in countryside. Basic wind speed is 46m/s based on a 3 second gust; the equivalent mean hourly wind speed is 23m/s.
8. Ground conditions:

Ground level – 0.8m	Made ground
0.8m – 4.0m	Stiff clay, C=150kN/m ²
4.0m – 15.0m	Sand and gravel, N varies between 5 and 40
Below 15.0m	Sandstone, allowable bearing pressure 1,000kN/m ²

 Groundwater was encountered at 0.8m below ground level.

Omit from consideration

9. Design of vehicle containment parapet.

SECTION 1

(50 marks)

- a. Prepare a design appraisal with appropriate sketches indicating two distinct and viable solutions for the proposed structure. Indicate clearly the functional framing, load transfer and stability aspects of each scheme. Identify the solution you recommend, giving reasons for your choice. (40 marks)
- b. After the design has been completed, the client advises that the river is to be increased in width by 10.0m at each side making the total width 90.0m and that the flood zones can be omitted. Write a letter to your client explaining the implications to your design. (10 marks)

SECTION 2

(50 marks)

For the solution recommended in Section 1 (a):

- c. Prepare sufficient design calculations to establish the form and size of all the principal structural elements including the foundations. (20 marks)
- d. Prepare general arrangement plans, sections and elevations to show the dimensions, layout and disposition of the structural elements and critical details for estimating purposes. (20 marks)
- e. Prepare a detailed method statement for the safe construction of the bridge and an outline construction programme. (10 marks)

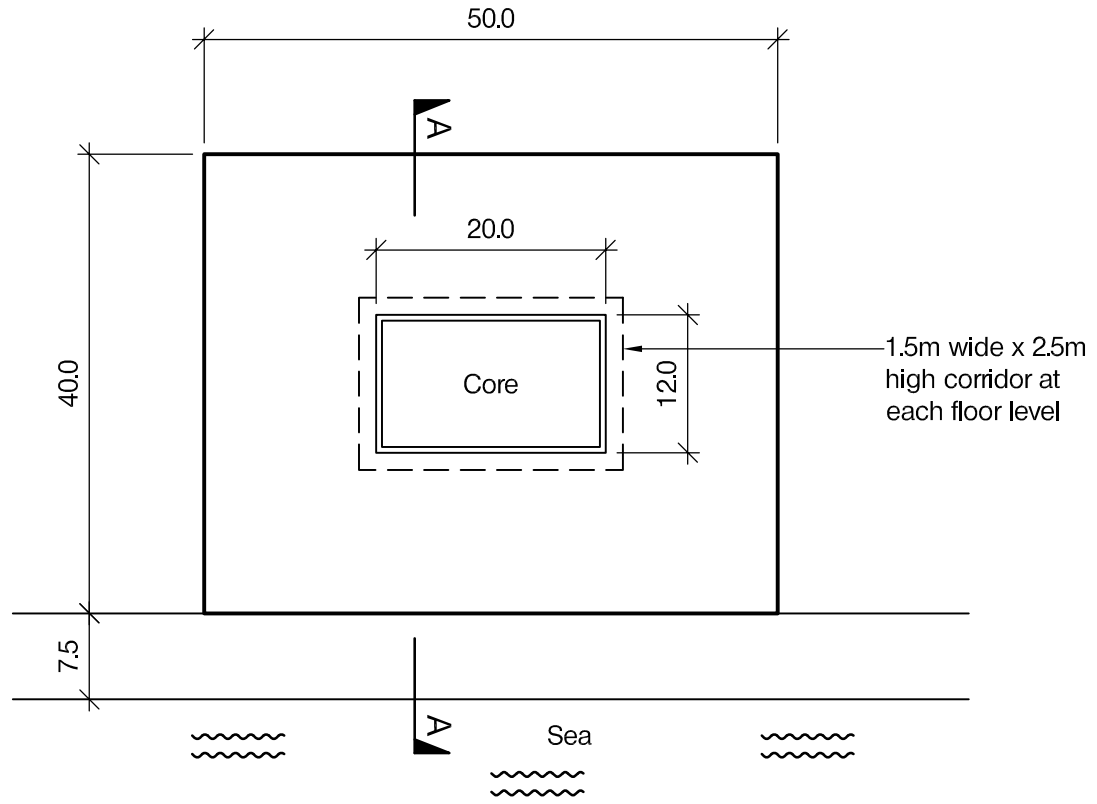

PLAN

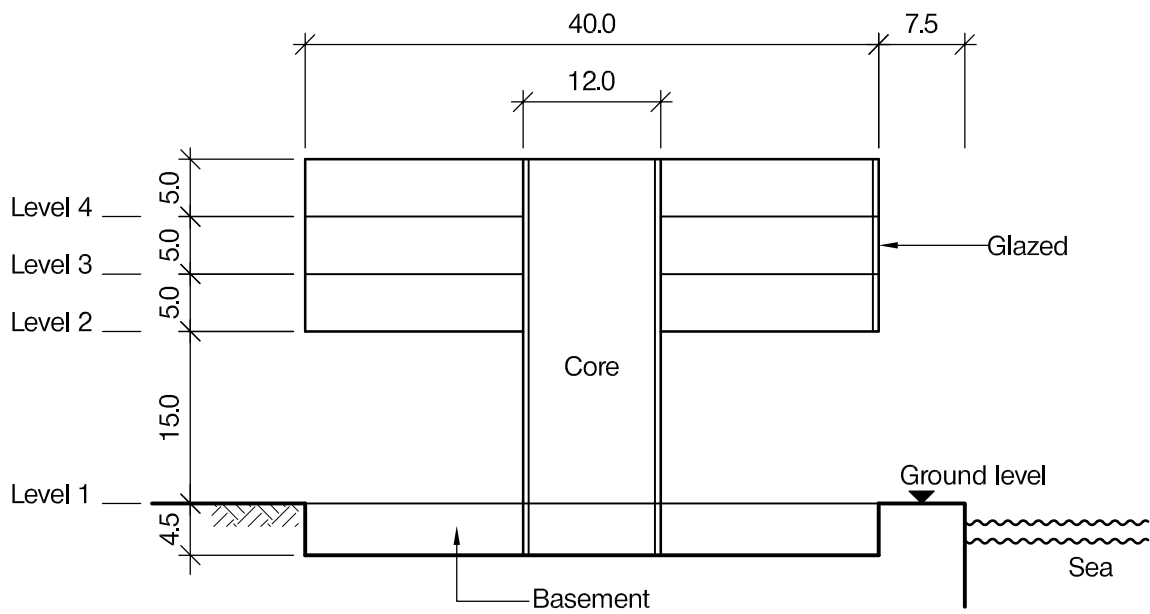

SECTION A-A

NOTE: All dimensions are in metres

FIGURE Q4

Question 4. New arts school

Client's requirements

1. A new arts school as shown in Figure Q4 is to be built near the seaside. The school has three storeys and a 4.5m deep basement, which is to be used as storage space.
2. No columns are permitted outside of the core at Level 1. The elevation facing the sea is fully glazed and no bracing is permitted on this elevation. Other elevations are to have a minimum of 50% glazed area. A 1.5m wide x 2.5m high continuous corridor is required around the core at each floor level.
3. A minimum fire resistance of 2 hours is required for structural elements.

Imposed loading

- | | |
|------------------------|-----------------------|
| 4. Roof | 2.0 kN/m ² |
| Floors (Levels 1 to 4) | 5.0kN/m ² |
| Basement | 5.0kN/m ² |

Site conditions

5. The site is adjacent to the sea. Basic wind speed is 40m/s based on a 3 second gust; the equivalent mean hourly wind speed is 20m/s.
6. Ground conditions:

Ground level - 8.0m	Reclaimed fill material
8.0m – 12.0m	Soft marine clays, C = 30kN/m ²
12.0m – 20.0m	Dense silty sand, N varies from 35 to 60
Below 20.0m	Rock with compressive strength of 5000kN/m ²

 Ground water was encountered at 3.0 m below ground level.

Omit from consideration

7. Detailed design of lifts and staircases inside the core.

SECTION 1

(50 marks)

- a. Prepare a design appraisal with appropriate sketches indicating two distinct and viable solutions for the proposed structure. Indicate clearly the functional framing, load transfer and stability aspects of each scheme. Identify the solution you recommend, giving reasons for your choice. (40 marks)
- b. After the design has been completed, the client advises that he wishes to have two levels of basement. Your client believes that if the floor to floor height of the basement is reduced to 3.0m the additional cost should be acceptable. Write a letter to your client explaining the feasibility and implications of this proposal. (10 marks)

SECTION 2

(50 marks)

- c. Prepare sufficient design calculations to establish the form and size of all the principal structural elements including the basement and foundations. (20 marks)
- d. Prepare general arrangement plans, sections and elevations to show the dimensions, layout and disposition of the structural elements and critical details for estimating purposes. (20 marks)
- e. Prepare a detailed method statement for the safe construction of the building and an outline design programme. (10 marks)

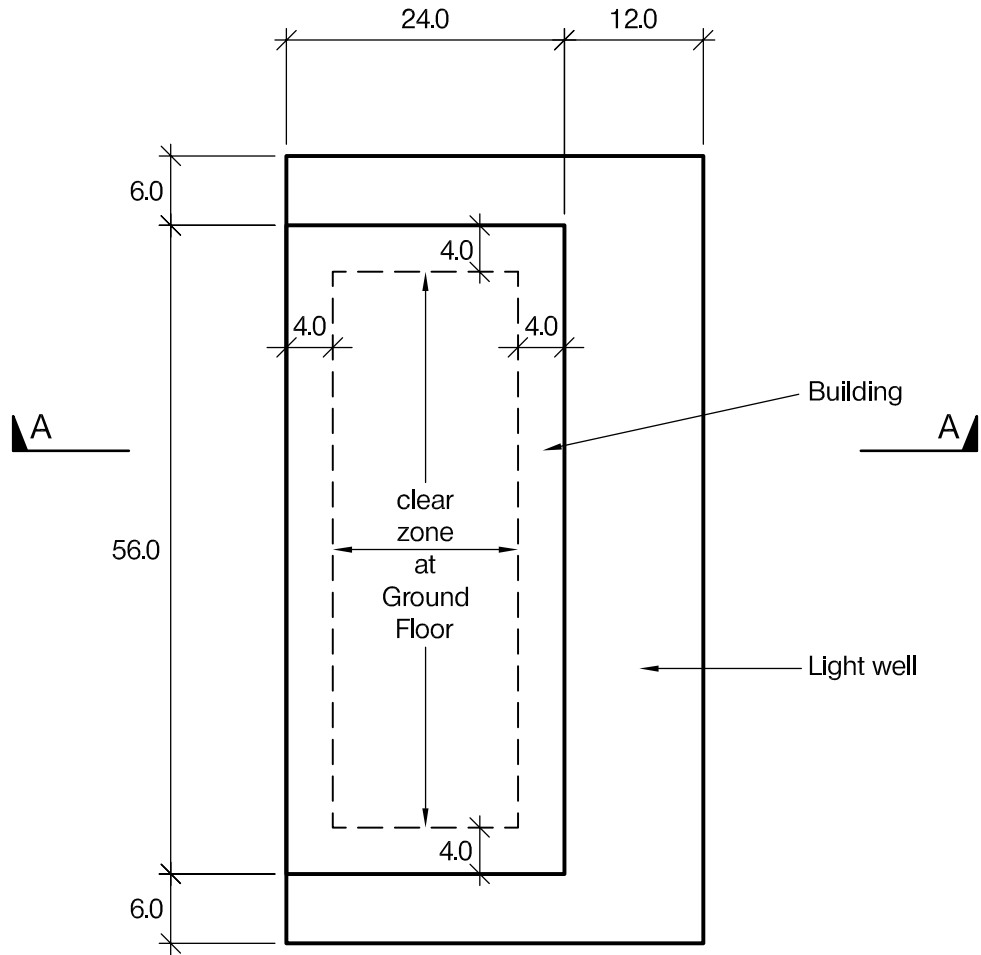

PLAN

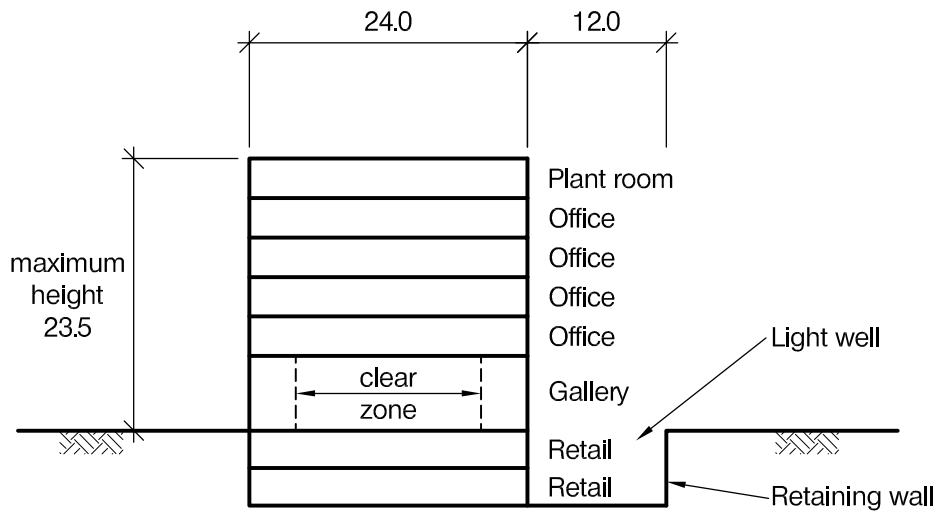

SECTION A-A

NOTE: All dimensions are in metres

FIGURE Q5

Question 5. Mixed use development

Client requirements

1. The client requires a mixed use development in a city centre. The development is to house 4 storeys of office above a gallery space at ground floor. There are to be two further storeys of basement below the gallery to house retail and café areas. There is also a top storey above the offices for a plant room. See Figure Q5.
2. There is a two storey light well around three sides of the building.
3. The client requires a zone of 16m x 48m to be clear of all vertical structure in the centre of the ground floor gallery space.
4. In the offices internal columns should be no closer than 8m to another column or core wall measured between the centre-lines. There is no restriction to wall or column locations in the top storey plant room or in the basement.
5. The structural clear height is to be 3.0m in all storeys except the gallery where it is to be 4.0m. The total height of the building should not exceed 23.5m.

Imposed loading

6. Roof	0.6kN/m ²
Plant room	7.5kN/m ²
Office and retail	5.0kN/m ²
Gallery	20.0kN/m ²

Site conditions

7. The site is located in a city centre. Basic wind speed is 46m/s based on a 3 second gust: the equivalent mean hourly wind speed is 23m/s.
8. Ground conditions:

0.0m – 3.0m	Made ground
3.0m – 8.0m	Silty sand, N = 35
Below 8.0m	Sandstone, bearing capacity 1000kN/m ²

 No ground water was encountered.

Omit from consideration

9. Detailed design of lifts and staircases inside core.

Section 1

(50 marks)

- a. Prepare a design appraisal with appropriate sketches indicating two distinct and viable solutions for the proposed structure. Indicate clearly the functional framing, load transfer and stability aspects of each scheme. Identify the solution you recommend, giving reasons for your choice. (40 marks)
- b. After completion of scheme design for the structure, the client wishes to know what effect removing the 6m wide light wells on either side of the building would have on the design. Write a letter to the client, advising on the structural implications of this. (10 marks)

Section 2

(50 marks)

For the solution recommended in Section 1(a):

- c. Prepare sufficient design calculations to establish the form and size of all the principal structural elements including the foundations and the retaining wall. (20 marks)
- d. Prepare general arrangement plans, sections and elevations to show the dimensions, layout and disposition of the structural elements and critical details for estimating purposes. (20 marks)
- e. Prepare a detailed method statement for the safe construction of the building and an outline construction programme. (10 marks)

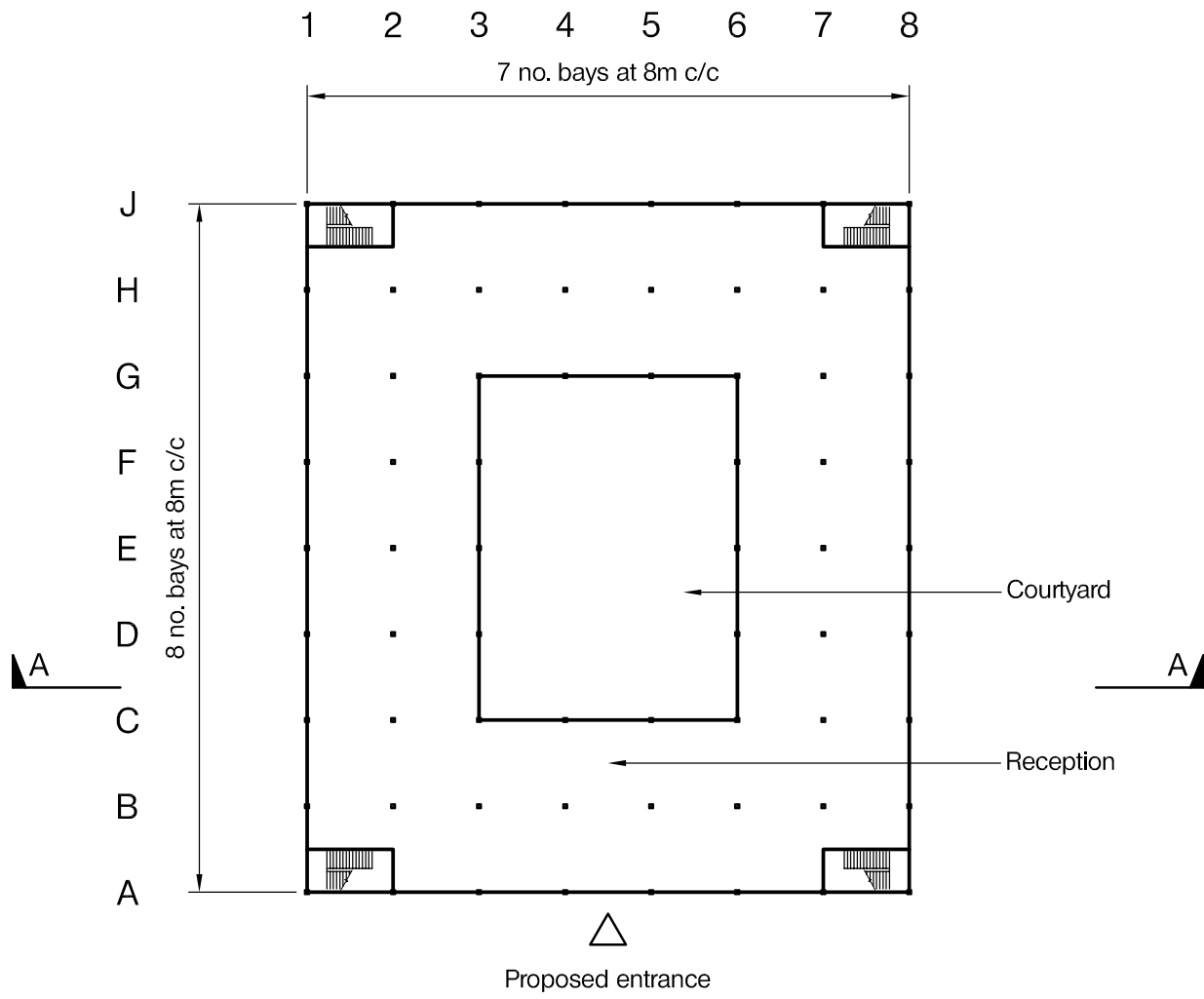

TYPICAL FLOOR PLAN

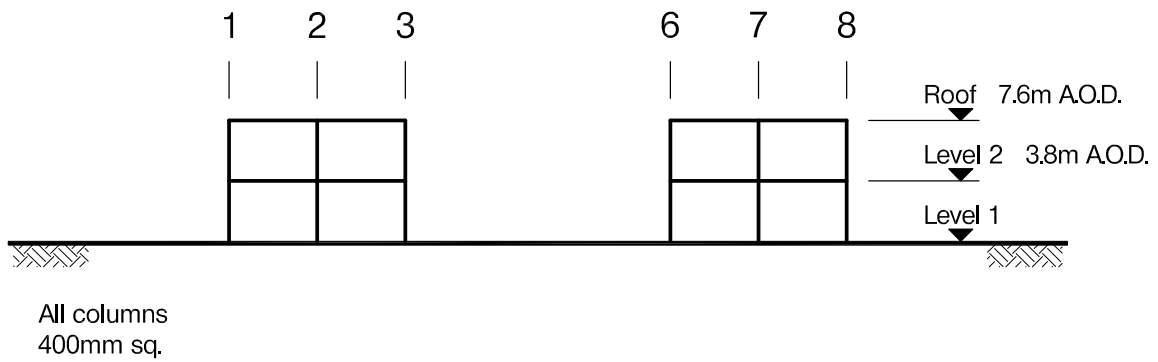

SECTION A-A

NOTE: All dimensions and levels are in metres

FIGURE Q6

Question 6. Refurbishment of an existing office building

Client's requirements

1. An existing two storey office building with a central courtyard as shown in Figure Q6 is to be refurbished. The work is to include the provision of an aesthetically pleasing roof over the courtyard and the opening up of the Level 2 slab over the reception area.
2. The roof to the courtyard must be at least 1m above the existing roof to allow space for ventilation.
3. One or more openings with a minimum total area of 32m² is/are to be provided in the floor slab at Level 2 above the reception area between grids A-C and 4-5.
4. The existing building has an insitu concrete frame with concrete flat slabs at Level 2 and roof level and cavity brickwork to the courtyard and external elevations. Existing construction comprises:
 - Roof - 300mm thick flat slab with 75mm asphalt screed
 - Level 2 - 300mm thick flat slab
 - Level 1 - 150mm thick ground bearing slab
 - Columns - 400mm square
 - Walls - 100mm brick, 100mm cavity, 140mm medium density concrete block
5. Details of the existing foundations are unknown and there are signs of minor differential settlement to the courtyard and external elevations.
6. Within the courtyard the column free area should be maximised.

Imposed loading

7.

	<u>Existing</u>	<u>Proposed</u>
Floors	4.0kN/m ²	2.5kN/m ²
Finishes	1.0kN/m ²	1.5kN/m ²
Roof	1.5kN/m ²	1.0kN/m ²

Site conditions

8. The site is situated on the outskirts of a town. Basic wind speed is 46m/s based on a 3 second gust; the equivalent mean hourly wind speed is 23 m/s.
9. Ground conditions below ground level which is approximately level

Ground level to 0.5m	Granular fill
0.5m to 2.0m	Loose silty sand with peat lenses
2.0m to 8.0m	Firm clay, C = 40kN/m ²
Below 8.0m	Stiff clay, C = 175kN/m ²

 Ground water is located at 1.5m below ground level.

SECTION 1

(50 marks)

- a. Prepare a design appraisal with appropriate sketches indicating two distinct and viable solutions for the proposed structure. Indicate clearly the functional framing, load transfer and stability aspects of each scheme. Identify the solution you recommend, giving reasons for your choice. (40 marks)
- b. After completion of your design the client asks for extra office floor area in excess of 700m² within the overall building footprint. Write a letter to your client explaining how this might be achieved advising the structural implications. (10 marks)

SECTION 2

(50 marks)

For the solution recommended in Section 1(a)

- c. Prepare sufficient design calculations to establish the form and size of all the principal structural elements including the foundations. (20 marks)
- d. Prepare general arrangement plans, sections and elevations to show the dimensions, layout and disposition of the structural elements and critical details for estimating purposes. (20 marks)
- e. Prepare a detailed method statement for the safe construction of the works and an outline construction programme. (10 marks)

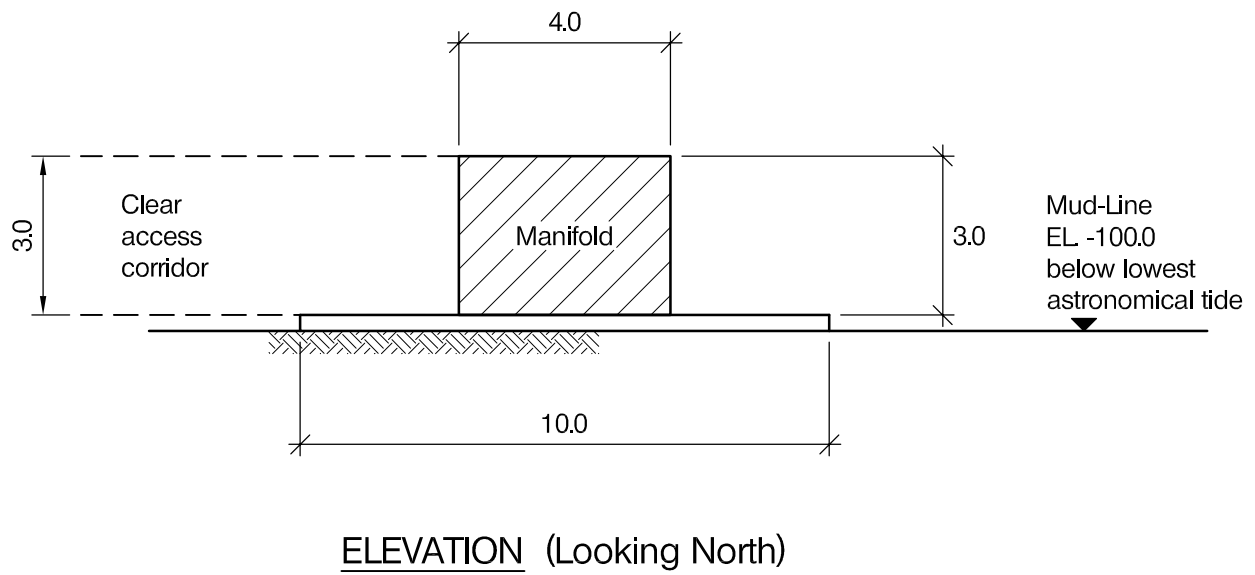
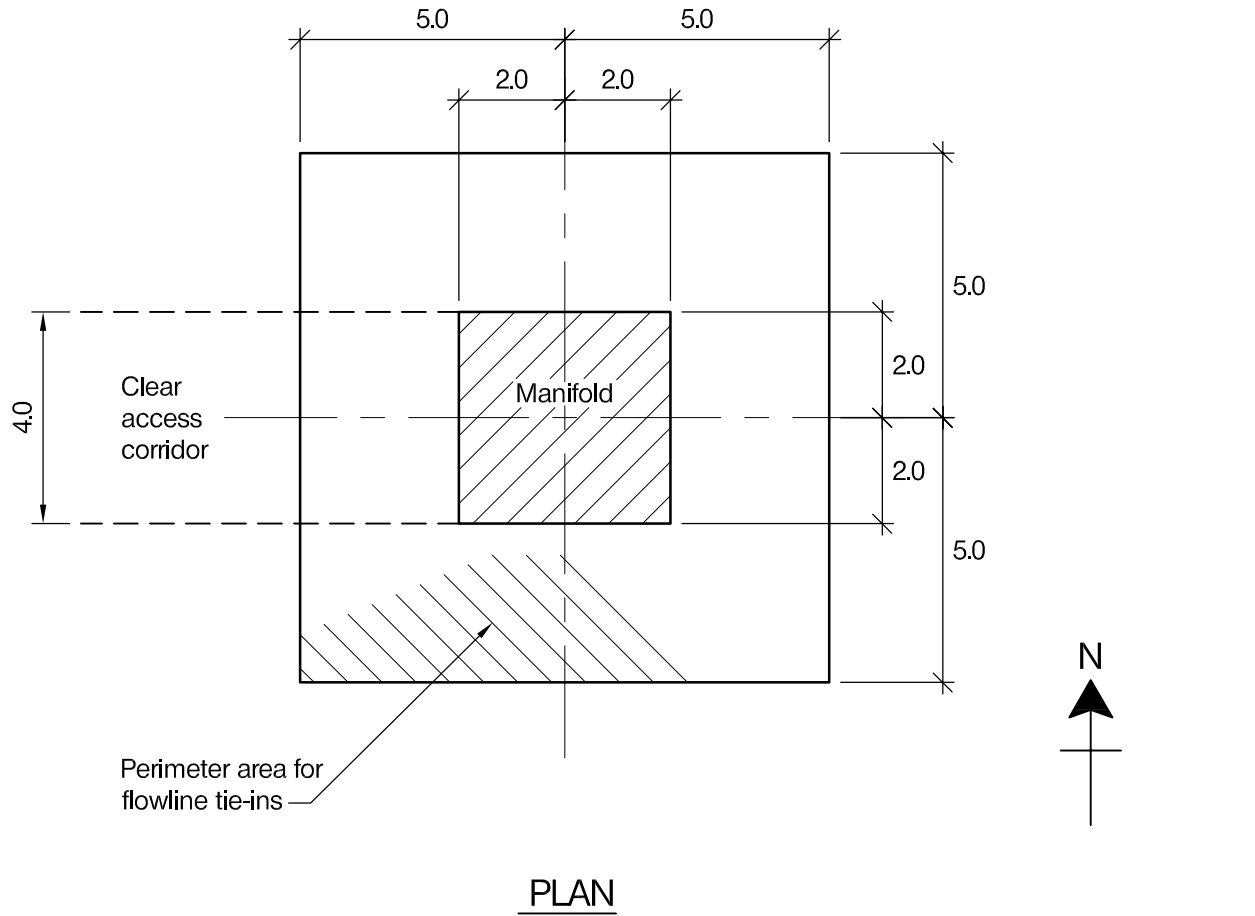

NOTE: All dimensions and levels are in metres

FIGURE Q7

Question 7. Subsea package for a new field development

Client's requirements

1. A new subsea package is to be installed on the seabed, in 100m of water, to combine oil production from a number of remote wells into a single export pipeline. The package is to have an area 10m x 10m to support incoming in-field flowlines, the export pipeline, and a 4m long x 4m wide x 3m high manifold unit located at the centre. The manifold may be considered solid. See Figure Q7.
2. The subsea package is located in an area that may experience fishing, and shall be designed to withstand fishing gear snag loads at any of the perimeter corners. A protection structure shall be provided above the manifold unit to prevent damage from objects from above.
3. The subsea package is to be piled to the seabed for support.
4. An access corridor to the west of the manifold is to be left clear of obstructions to ensure access for ROV or diver intervention, see Figure Q7.
5. The package is to be transported to the field location on a large Diving Support Vessel and lowered into place using the vessel crane. The vessel crane has no heave compensation mechanism.

Imposed loading

- | | |
|---|--|
| 6. Uniformly distributed load on the flowline tie-in area | 10kN/m ² dry, 8kN/m ² submerged (not including the manifold area). |
| Manifold unit weight | 500kN |
| Maximum crane jib motion during installation | 10m total heave in a 10sec period |
| Fishing gear snag load | 1,000kN in any direction |

Omit from consideration

7. In-place environmental conditions.
8. Soil strength checks. For the purpose of pile design, the piles may be considered to be laterally and axially supported at a depth of 6 pile diameters below the mudline.
9. Individual local design of the flowline supports.

SECTION 1

(50 marks)

- a. Prepare a design appraisal with appropriate sketches indicating two distinct and viable solutions for the proposed subsea package. Indicate clearly the functional framing, support constraints, load transfer and stability aspects of each scheme for the relevant temporary and permanent design phases. Identify the solution you recommend, giving reasons for your choice. (40 marks)
- b. After completion of your design, the client informs you that he wishes to extend the base area on the east side by 2m to incorporate an increase in the size of the flowline tie-in porches. Write a letter to the client explaining how this might be accomplished and the effects this would have on your chosen solution. (10 marks)

SECTION 2

(50 marks)

For the solution recommended in Section 1(a):

- c. Prepare sufficient design calculations, for both the temporary and permanent conditions, to establish the form and size of all the principal structural elements and connections, including the pile connections to the structure and the lift points. (20 marks)
- d. Prepare general arrangement plans, sections and elevations to show the dimensions, layout and disposition of the structural elements and critical details for estimating purposes. (20 marks)
- e. Prepare a detailed method statement for the safe transport and installation of the subsea package to the seabed location. (10 marks)

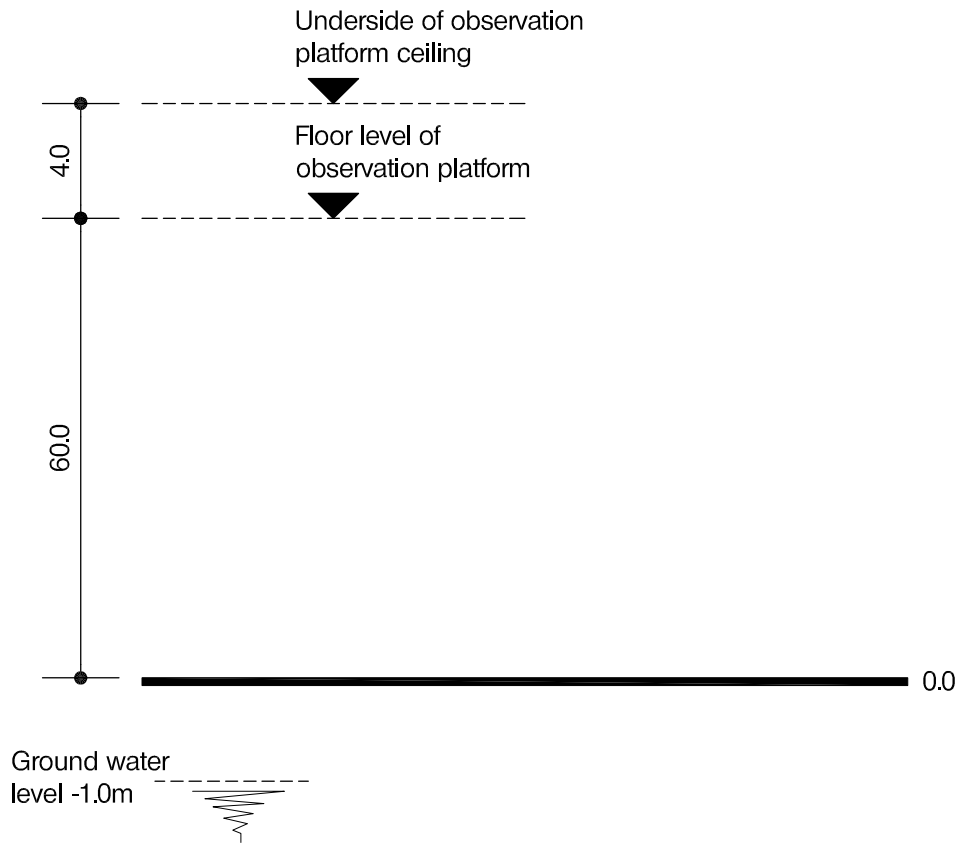

FIGURE Q8-1 Elevation on platform

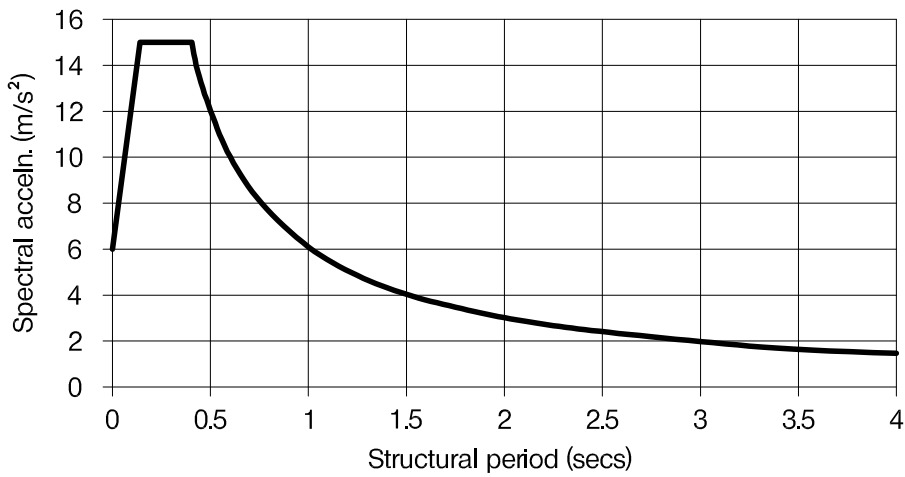

FIGURE Q8-2 : 475 year return period 5% damped spectrum for the region for rock with a shear wave velocity V_s of at least 800m/s at the surface

NOTE: All dimensions and levels are in metres

FIGURES Q8-1 and Q8-2

Question 8. An observation platform

Client's requirements

1. The client requires a permanent observation platform, to be constructed close to the centre of a major city, in an area of high seismicity.
2. The observation platform will be 60m above ground level and must be fully enclosed by glass façades and a roof, as indicated in Figure Q8-1. The floor to ceiling height must be at least 4m.
3. The public access area of the observation platform must be structure free (columns or bracing) and have a minimum area of 100m². Numbers and size of glazing mullions must be minimised.
4. The architect has requested that the cross sectional area of the shaft be limited to 36m².
5. The site is 30m square in plan, standing at the corner of two major highways. A service building is required at ground level which provides 400m² minimum of useable floor area (including offices and conveniences).
6. There are no structural restrictions in the service building but the architectural form should enhance the experience of visitors.
7. At least two means of access are required between the service building and observation tower, one of which must be suited to disabled users. One means of access may be reserved for emergency use only.

Imposed loading

8. Observation platform floor	5.0kN/m ²
Service building floor	2.5kN/m ²
Stair and lift area	4.0kN/m ²
Roof	1.0kN/m ²

Site conditions

9. The site is located in an inner city area. The basic wind speed is 40m/s based on a 3-second gust; the equivalent mean hourly wind speed is 20 m/s.
10. Dense sand to depth, $N = 25$. Water table is located at 1.0m below existing ground level.
11. Figure Q8-2 shows the design 5% damped seismic response spectrum for the region. It applies to level ground for a 475 year return period, assuming the ground surface is rock with a shear wave velocity of not less than 800m/s.

Omit from consideration

12. Detailed design of any staircases or lifts.

SECTION 1

(50 marks)

- a. Prepare a design appraisal with appropriate sketches indicating two distinct and viable solutions for the proposed structure. Indicate clearly the functional framing, load transfer and stability aspects of each scheme. Identify the solution you recommend, giving reasons for your choice. (40 marks)
- b. After completion of scheme design for the structure, the client inquires whether it will be possible to move the lift to the edge of the platform. Write a letter for the client, advising on the structural implications of this change, with a description of ways of accommodating it. (10 marks)

SECTION 2

(50 marks)

For the solution recommended in Section 1(a):

- c. Prepare sufficient design calculations to establish the form and size of all the principal structural elements including the foundations. (20 marks)
- d. Prepare general arrangement plans, sections and elevations to show the dimensions, layout and disposition of the structural elements and critical details for estimating purposes. (20 marks)
- e. Prepare a detailed method statement for the safe construction of the structure and an outline construction programme. (10 marks)

The Institution of Structural Engineers
International HQ
11 Upper Belgrave Street
London SW1X 8BH
United Kingdom
tel: +44 (0)20 7235 4535
fax: +44 (0)20 7235 4294
mail@istructe.org
www.istructe.org
Registered Charity