

Associate-Membership Examination

Wednesday 7 September 2022

Structural Engineering Design and Practice

09.30 – 13.00 and 13.30 – 17.00 (Discussion between individuals is not permitted during lunch period). A period of fifteen minutes is provided for reading the question paper, immediately before the commencement of the examination. Candidates are not permitted to write in answer sheets, or on drawing paper or to use a calculator during this time. Candidates must satisfy the Examiners in ONE question.

Important

The written answer to the question selected and any A3 drawings must bear the candidate's number and the question number at the bottom of the page. Only the answer sheets supplied by the Institution may be used. The candidate's name should not appear anywhere in the script.

Notes to Candidates

1. TO PASS THE EXAMINATION, CANDIDATES MUST SATISFY THE EXAMINERS IN BOTH PARTS OF THE QUESTION ATTEMPTED.
2. Candidates should note that Figures are produced to illustrate the question and are not necessarily drawn to scale. Figured dimensions should be followed.
3. A fair proportion of marks will be awarded for the demonstration of an understanding of fundamental engineering concepts, as distinct from calculation of member forces and sizes. NOTE: In the calculation part of all questions, establishing "form and size" is taken to mean compliance with all relevant design criteria, i.e. bending, shear, deflection, etc.
4. In all questions 30 marks are allocated to Section 1 and 70 marks to Section 2.

5. The Examiners are looking for sound structural designs. It should also be remembered that aesthetics, economy and function are important in any competent engineering scheme.
6. Any assumptions made and the design data and criteria adopted must be stated.
7. Good clear drawings and sketches are required; they should show all salient and structural features to suitable scales and should incorporate adequate details.
8. Candidates will not be allowed to include any previously prepared calculations, notes, sketches, diagrams, computer output or other similar material in their answer sheets or A3 drawings. Any previously prepared information submitted by candidates will be ignored by the examiners.
9. Candidates may not bring into the examination room any electronic devices capable of wireless communication, optical photography or scanning.

The following devices are not permitted: Mobile phones, Laptops, notebooks or portable computers and similar devices, iPads, tablets and similar devices, E-readers (e.g. Kindle) and similar devices, Cameras, optical scanners and similar devices.

Any candidates arriving at the examination room with such devices will be asked to switch them off and place them in a sealed bag kept by the Invigilator for the duration of the exam, which includes the lunch period.

10. This paper is set in SI Units.

Now read 'Reminder' on page 3.

Associate-Membership Examination, a reminder from your Examiners

The work you are about to start has many features in common with other examinations which you have tackled successfully but it also has some which are unusual.

As in every examination you must follow carefully the NOTES FOR CANDIDATES set out for your guidance on the front cover of this paper; allocate the available time sensibly and set out your work in a logical and clear way.

The unusual requirement of the examination is that you demonstrate the validity of the training and experience that you have acquired in recent years.

The Institution must be satisfied that you are able to bring all the various skills you are expected to possess to the effective solution of structural design problems whether or not the problem is presented in terms that are within your actual experience.

Chartered Structural Engineers must have the ability to design and a facility to communicate their design intentions. Where you are required to list and discuss possible structural solutions you must show by brief, clear, logical and systematic presentation that you understood the general structural engineering principles involved.

In selecting and developing your design you should also remember the guidance given in the Institution's report, Structural design - achieving excellence, and in particular:

- (1) "the structure must be safe",
- (2) "a good design has certain typical features – simplicity, unity and necessity",
- (3) "the structure must fulfil its intended function".

If you have difficulty in deciding the correct interpretation of a question, pay particular attention to point 6. notes to candidates, on the front cover. The examiners will take into account your interpretation – and the design you base on this – if this is clearly stated at the beginning of your answer.

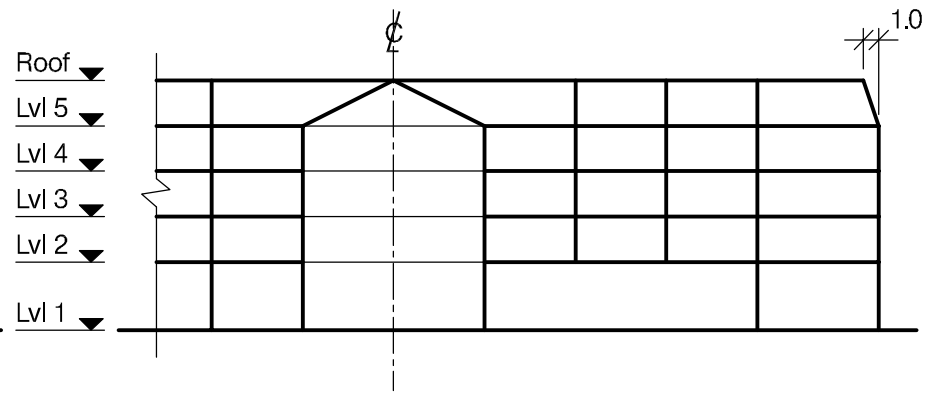
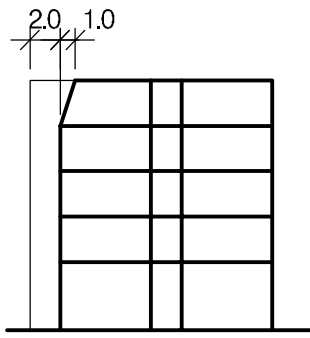
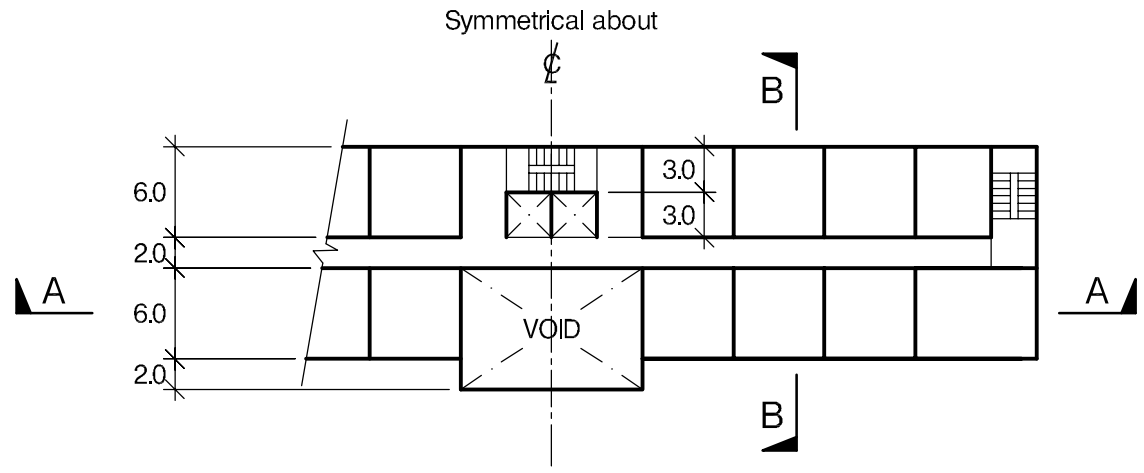
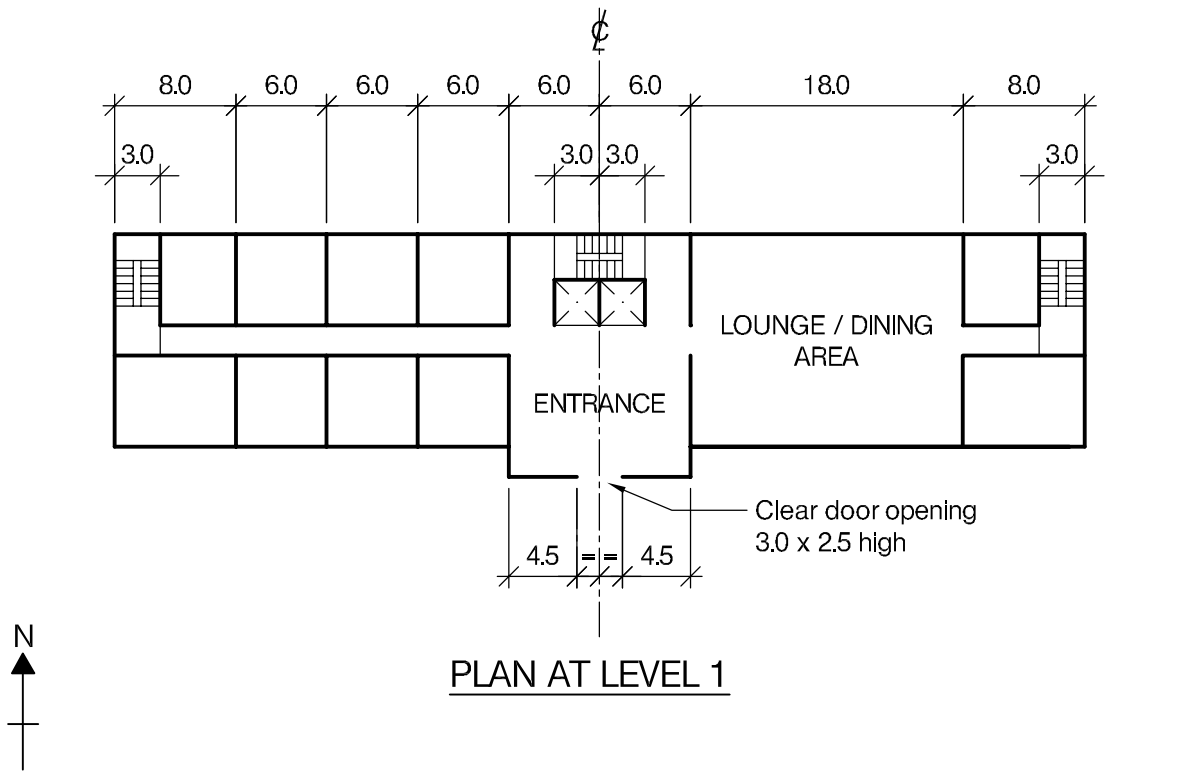

NOTE: All dimensions are in metres

FIGURE Q1

Q1. New Hotel Development

Client's requirements

1. A new four storey hotel development consisting of 74 bedrooms. See Figure Q1.
2. The development is to have 10 bedrooms at Level 1 and 16 bedrooms per floor from Level 2 to Level 5.
3. A lounge /dining area is required to the east of the entrance area. Only one internal column is permitted within this area
4. Access to the upper floors is by a 6.0m x 6.0m core consisting of two elevators and a main staircase in the entrance area, and two escape staircases at the end of the projecting wings
5. No internal columns are permitted inside the entrance area or inside any of the bedrooms
6. External and internal columns are to have a minimum spacing of 6.0m
7. A minimum clear internal height of 4.0m is required to Level 1 and 2.6m at Levels 2 to 5. Each floor is to have a false ceiling service zone of 0.3m below any structure.
8. All elevations to the development are to be clad with insulated decorative composite panels, except the south elevation to the entrance, which is to be fully glazed with no bracing permitted.
9. The fire rating to the development is 2 hours

Imposed loading

- | | |
|--------------|-----------------------|
| 10. Roof | 0.75kN/m ² |
| 11. Bedrooms | 2.50kN/m ² |
| 12. Level 1 | 5.0kN/m ² |

Site conditions

13. The site is located in the outskirts of a large city. Basic wind speed is 42.0m/s based on a 3 second gust; the equivalent mean hourly windspeed is 20.0m/s.

14. Ground conditions vary linearly from West to East across the site:

West		East
Ground level -0.5m	made ground	Ground level -1.5m
0.5m – 2.0m	silty sand N value 25	1.5m – 3.0m
Below 2.0m	very dense sand and gravel N value 45	Below 3.0m
No groundwater was encountered		

Omit from consideration

15. Detail design of the elevator and stairs.

SECTION 1

(30 marks)

- a) Prepare a design appraisal with appropriate sketches indicating a viable solution for the proposed structure including the foundations. Indicate clearly the functional framing, load transfer, serviceability and stability aspects of the scheme. Justify the reasons for your solution (20 marks)
- b) After the design is complete and before construction commences the client advises you that he wishes to add a basement under the Lounge / Dining area for storage with a clear internal height of 2.6m. Write a letter to the Client explaining the implications on your design and the construction.

(10 marks)

SECTION 2

(70 marks)

For the solution recommended in Section 1(a):

- c) Prepare sufficient design calculations to establish the form and size of all the principal structural elements including the foundations. (30 marks)
- d) Prepare general arrangement drawings, which may include plans, sections and elevations to show the dimensions, layout and disposition of the structural elements for estimating purposes. Prepare clearly annotated sketches to illustrate details of:
 - a) Internal column to floor connection at Level 2 in the Lounge / Dining Area and columns over
 - b) Perimeter column, ground slab, and foundation detail

(30 marks)

- e) Prepare a detailed method statement for the safe construction of the building

(10 marks)

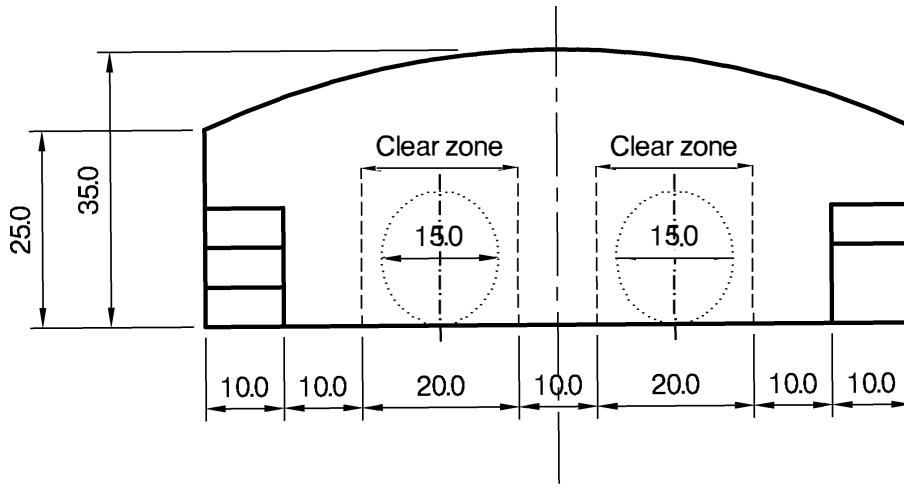

SECTION A - A

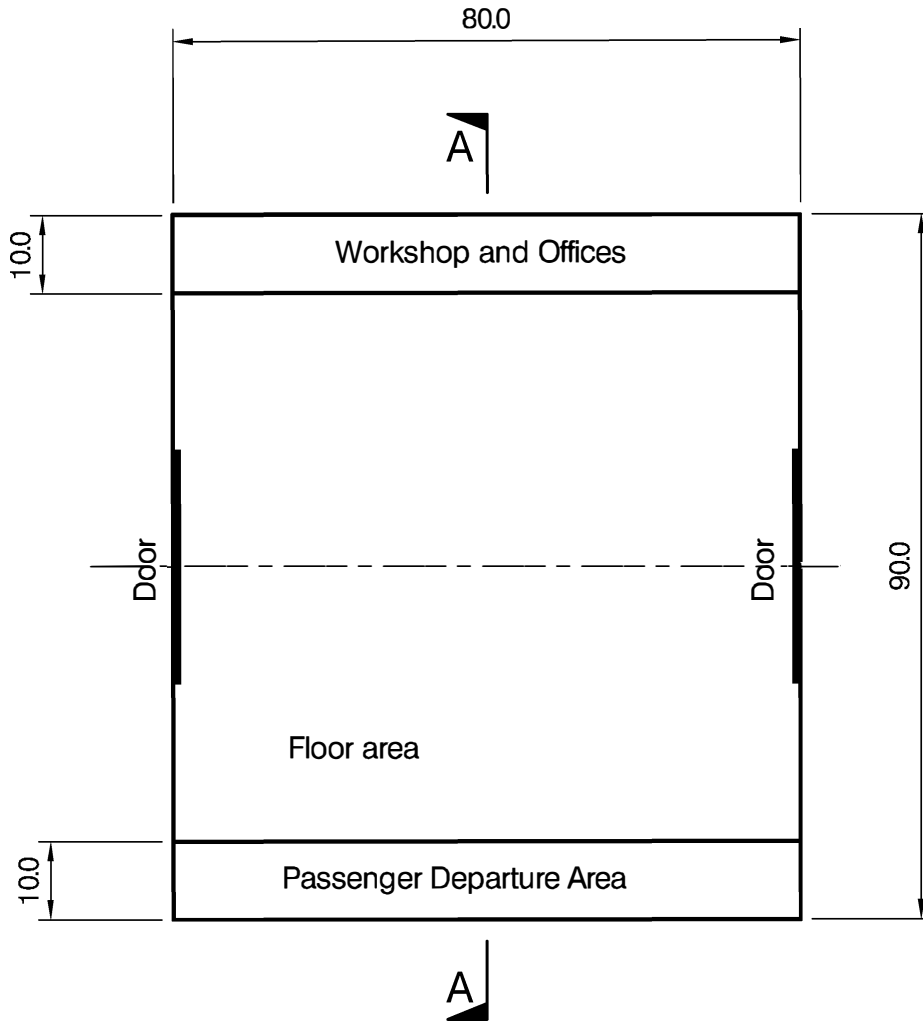

PLAN

NOTE: All dimensions are in metres

FIGURE Q2

Q2. Airship Hangar

Client's requirements

1. The client requires a new building to accommodate two lighter-than-air dirigible balloons (airships) – see Figure Q2. Each airship is elliptical being 18m high and 15m wide.
2. The building is to have an unobstructed clear zone of 50m long by 20m wide by 20m high for each airship.
3. At one end of the building a 30m wide x 20m high door opening is required. This door is to be supported on an overhead sliding rail.
4. 30 percent of the roof of the building is to be glazed to allow for natural daylight.
5. A 10m wide by 80m long three-storey passenger departure area is required, (refer to Figure Q2) at each level the clear floor to ceiling height is to be 5m.
6. A 10m wide by 80m long double-storey workshop area with a single-storey office area above is also needed. In the workshop the clear floor to ceiling height is to be 10m and 5m in the offices.
7. The curvature of the roof is to suit the structural form of the building.
8. Columns are not permitted within the span of the passenger departure area, workshop, office and main hanger floor area.
9. The cladding solution is to maximise sustainability.
10. External dimensions are not restricted.

Imposed loading

11. Moveable hanger door weight 912 kN applied as two travelling point load at a spacing of 4m
 Hanger floor load 25 kN/m²
 Workshop, office and departure area 5kN/m²
 Roof loading 3 kN/m²

Site conditions

12. Flat edge of town location. Basic wind speed is 46m/s based on a 3-second gust; the equivalent mean hourly wind speed is 23m/s

Ground conditions

13. Ground Level – 0.5m Made ground
 1.5m – 15m Dense gravel, N = 20 increasing with depth to N = 40
 Below 15m Rock, allowable safe bearing pressure 500 kN/m²
 Ground water is present 5m below ground level.

SECTION 1

(30 marks)

- a) Prepare a design appraisal with appropriate sketches indicating a viable solution for the proposed structure including the foundations. Indicate clearly the functional framing, load transfer, serviceability and stability aspects of the scheme. Justify the reasons for your solution (20 marks)
- b) After the scheme design is complete, the Client advises you that in order to complete repairs, the lighter-than-air dirigible balloons (airships), need to be able to float upward in the air dock to a height of 30m. Write a letter to the Client explaining the implications on your design. (10 marks)

SECTION 2

(70 marks)

For the solution recommended in Section 1(a):

- c) Prepare sufficient design calculations to establish the form and size of all the principal structural elements including the foundations. (30 marks)
- d) Prepare general arrangement drawings which may include plans, sections and elevations to show the dimensions, layout and disposition of the structural elements for estimating purposes. Prepare clearly annotated sketches to illustrate details of:
 - a) A perimeter column, ground slab and foundations detail
 - b) A perimeter column and the roof structure
 (30 marks)
- e) Prepare a detailed method statement for the safe construction of the building (10 marks)

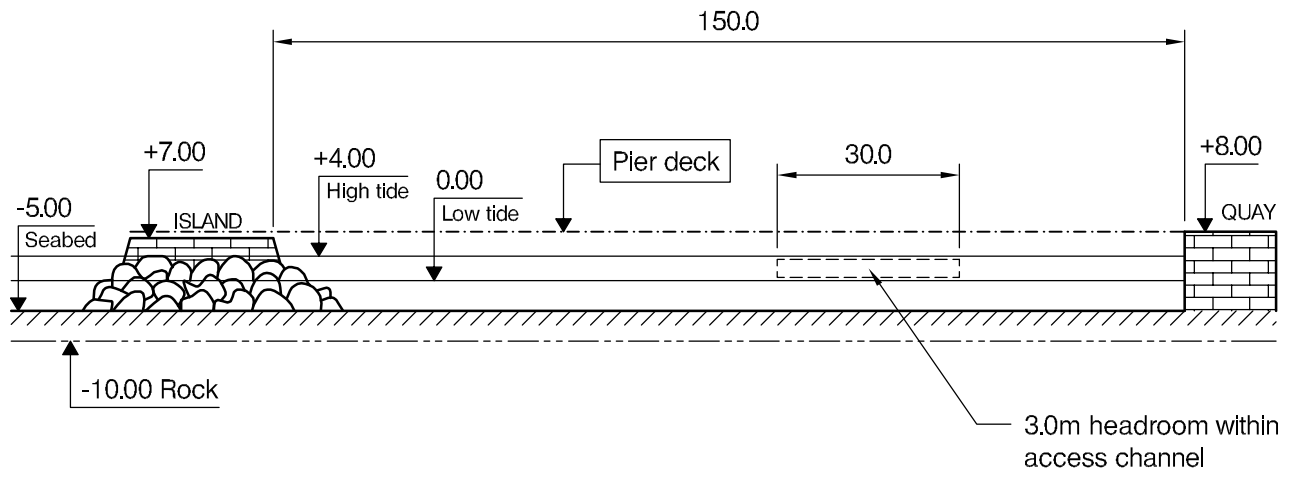

ELEVATION

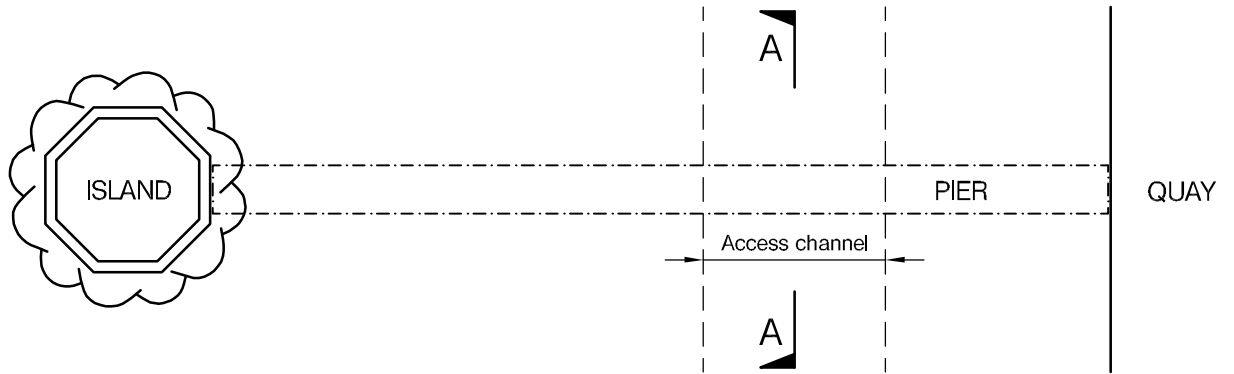

PLAN

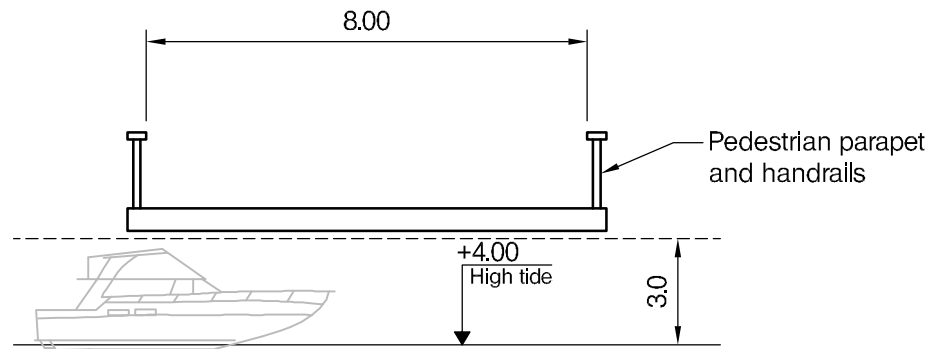

SECTION A - A

NOTE: All dimensions are in metres

FIGURE Q3

Q3. Waterfront pedestrian pier

Client's requirements

1. A new 150m long pedestrian promenade pier is required to provide access from an existing stone quay wall to an existing historical man-made island as shown in Figure Q3. The client has requested that the structure be as economic with materials as possible to create minimal physical and visual disturbance at the site.
2. The structure shall not impose any horizontal loads onto the existing walls at each end of the pier. Any vertical reaction imposed on top of the existing structures at each end is not to exceed 50kN.
3. The new pier deck shall be 8m wide to accommodate pedestrians and cyclists and shall include 1.5m high edge parapet handrails on each side. The maximum gradient along the route cannot exceed 1 in 20.
4. The proposed structure shall incorporate a 30m wide with 3m vertical clearance access channel for small motorboats to pass under the pier. Any new foundation shall be set with 3m minimum horizontal clearance to the island and the quay wall. Supports adjacent to the access channel are to be designed to withstand an accidental vessel impact load.
5. The water level has a tidal range of 4m. To minimize the impact to the existing hydraulic flow, 15m minimum horizontal clearance between internal supports is required above low tide along the length of the structure.
6. No structural element shall extend above the deck level, except the edge parapets.

Imposed loading

7. Vertical loads from pedestrians and cyclists = 5 kN/m²
8. Horizontal loading along the edge parapet handrails = 1.0 kN/m
9. Maintenance vehicle: 10 kN wheel load over 100mm square contact area
10. Accidental vessel impact load = horizontal force of 100 kN applied at water level (any direction)

Site conditions

10. The site is in a coastal location and marine environment. Basic wind speed is 50 m/s based on a 3 second gust; the equivalent mean hourly wind speed is 25 m/s.
11. No temporary works are allowed to be placed on the seabed.
12. Ground conditions
 - Seabed: alluvium 0.5 m thick with $C_u = 20 \text{ kN/m}^2$
 - Stiff clay: 4.5 m thick with C_u increasing linearly from $C_u = 100 \text{ kN/m}^2$ to 150 kN/m^2 .
 - Rock: allowable bearing pressure of 1500 kN/m^2 at 5m below the seabed.

Omit from consideration

13. Hydrodynamic effects and wave forces may be ignored.

SECTION 1

(30 marks)

- a) Prepare a design appraisal with appropriate sketches indicating a viable solution for the proposed structure including the foundations. Clearly indicate the functional framing, load transfer, serviceability, and stability aspects of the scheme. Justify the reasons for your solution. (20 marks)
- b) After your recommended solution has been accepted in principle, the Client advises that the vertical clearance of the navigational section is to be increased to 5m. Write a letter to the Client explaining the design and construction implications and advising in which way the design would need to be modified. (10 marks)

SECTION 2

(70 marks)

For the solution recommended in Section 1(a):

- c) Prepare sufficient design calculations to establish the form and size of all the principal structural elements for the pier and the span across the access channel, including the foundations. (30 marks)
- d) Prepare general arrangement drawings which may include plans, sections and elevations to show the dimensions, layout and disposition of the structural elements for estimating purposes. Prepare clearly annotated sketches to illustrate details of:
 - a) Connection of the decking to the quay wall
 - b) Connection of the pedestrian parapet and handrail to the bridge decking (20 marks)
- e) Prepare a detailed method statement for the safe construction of the pier (10 marks)

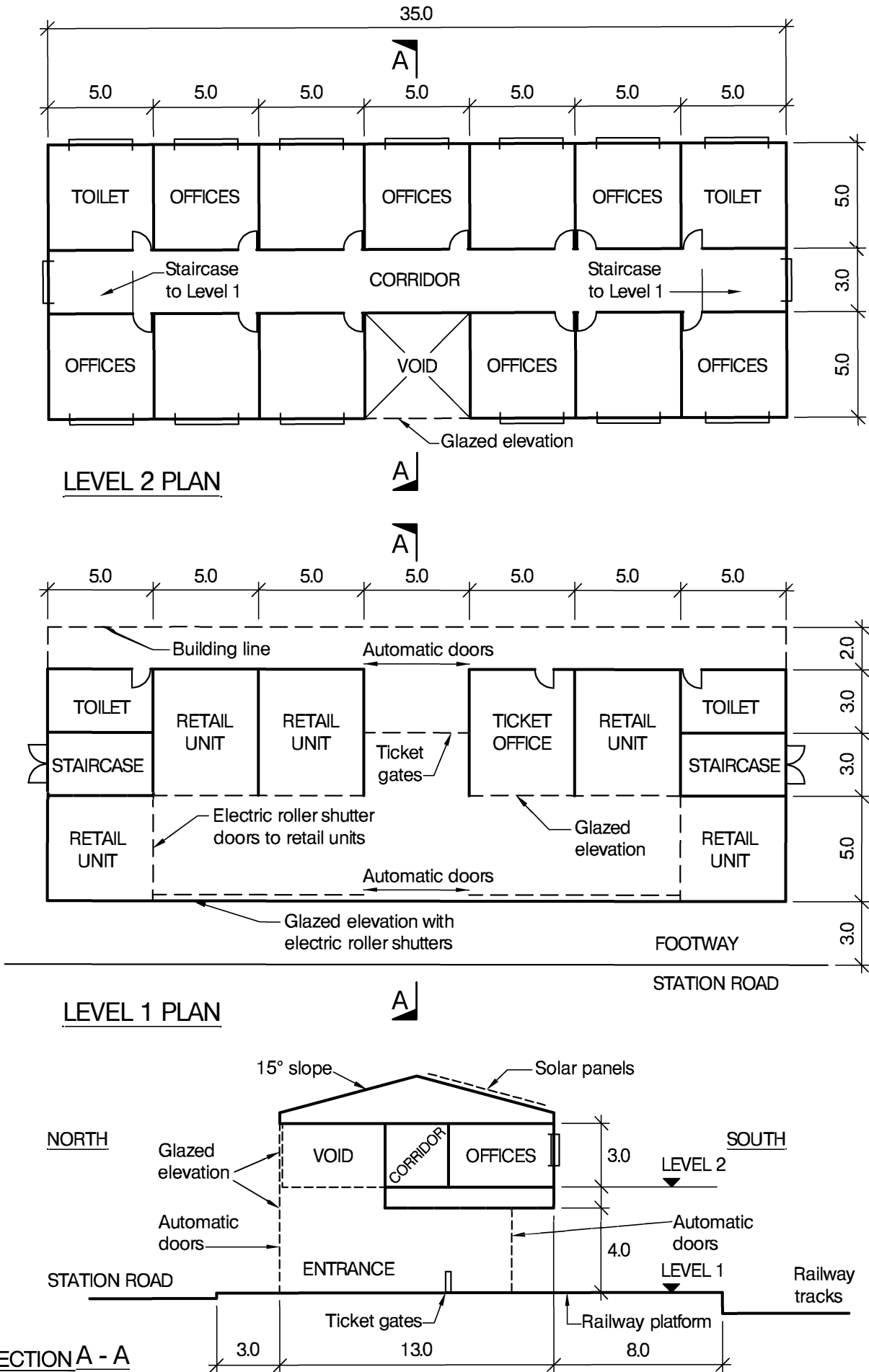

NOTE: All dimensions are in metres

FIGURE Q4

Q4. Railway Station Building

Client's requirements

1. A 2-storey railway station building. The ground floor (Level 1) provides pedestrian access to the adjacent railway platforms, ticket offices, retail units, public toilets and stairs to Level 2 floor. Level 2 floor accommodates offices and toilet facilities. See Figure Q4.
2. A minimum clear headroom of 4.0m is to be provided to Level 1 floors and 3.0m to Level 2 floors.
3. Internal columns are only permitted within the internal walls/ partitions of the building. External columns along the building line are to be kept to a minimum, particularly the north elevation (station entrance) and the south elevation (to the railway platforms).
4. Level 1 north elevation is to be glazed with automatic doors for pedestrian access. Electrically operated roller shutters are to be provided to the pedestrian access and retail units when the station and retail units are closed.
5. Water tanks and electrical equipment are to be located above Level 2 ceilings to the toilets.
6. Cladding to the roof and elevations is to be selected to minimise energy consumption and maintenance costs. Solar panels of 100 square metres are to be provided on the south side roof. Level 2 windows are 2.0m wide by 1.5m high.
7. A minimum 1-hour fire resistance is required for all principal structural elements.

Imposed loading

- | | |
|----------------|----------------------|
| 8. Roof | 0.6kN/m ² |
| Solar panels | 0.2kN/m ² |
| Levels 1 and 2 | 5.0kN/m ² |
- Loadings include an allowance for partitions, ceilings and services.

Site conditions

9. The site is flat and level and is located on the edge of a town.
Basic wind speed is 44m/s based on a 3-second gust; the equivalent mean hourly wind speed is 22m/s.
10. Typical ground conditions:

Ground level - 0.5m	Made ground N values vary below 5
0.5m – 4.0m	Sand and Gravel. N values increase with depth 15 to 30
4.0m – 15m	Very stiff Clay. C = 250kN/m ²

No groundwater was encountered.

Omit from consideration

11. Detailed design of the staircases, roller shutter doors and ticket gates.

SECTION 1

(30 marks)

- a) Prepare a design appraisal with appropriate sketches indicating a viable solution for the proposed structure including the foundations. Indicate clearly the functional framing, load transfer, serviceability and stability aspects of the scheme. Justify the reasons for your solution. (20 marks)
- b) After you have completed your design, the client informs you that major underground services have been found in a concrete duct 1m wide by 1m deep along the centreline of the proposed west elevation, the top of which is at 1m below ground level. Write a letter to the client explaining the impact on your design and what changes would be required. (10 marks)

SECTION 2

(70 marks)

For the solution recommended in Section 1(a):

- c) Prepare sufficient design calculations to establish the form and size of all the principal structural elements including the foundations. (30 marks)
- d) Prepare general arrangement drawings which may include plans, sections and elevations to show the dimensions, layout and disposition of the structural elements for estimating purposes. Prepare clearly annotated sketches to illustrate details of:
 - a) A perimeter column, ground slab and foundation detail
 - b) Roof structure to external column. (30 marks)
- e) Prepare a detailed method statement for the safe construction of the building (10 marks)

International HQ,
47-58 Bastwick Street,
London EC1V 3PS, UK

T +44 (0)20 7235 4535

E membership@istructe.org

www.istructe.org
